

## Transmission, identification

The 6-speed manual transmission 01E (all wheel drive) is installed in Audi S4 vehicles in conjunction with the 2.7 liter bi-turbo engine.  
Allocation ⇒ [Page 00-3](#) .

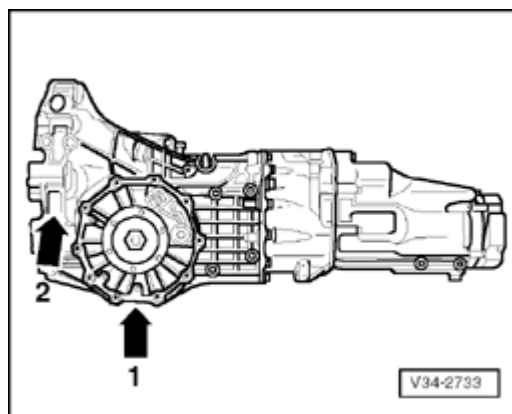

### Location on transmission

- ◆ Code letters and serial number (arrow -1-).
- ◆ Manual transmission 01E (arrow -2-).

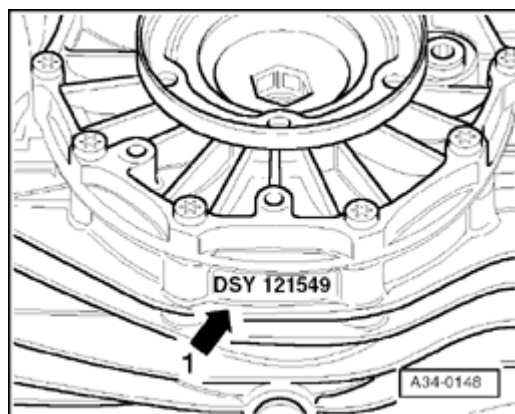

**A Code letters and transmission consecutive serial number (arrow -1-)**

<b>Example:</b>	<b>EDU</b>	<b>136549</b>
	Code letters	Transmission consecutive serial number

Additional data depends on manufacture.

**Note:**

*The transmission code letters are also included on the vehicle data stickers.*

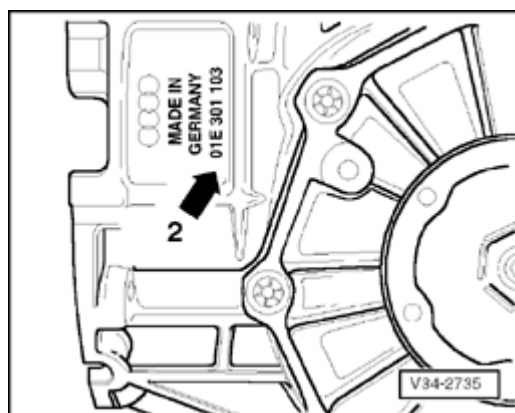

**A Manual transmission 01E (arrow -2-)**

### Code letters, allocation, ratios, and capacities

<b>Manual transmission</b>		<b>6-speed 01E all wheel drive</b>
<b>Code letters</b>		<b>EDU</b>
<b>Manufactured</b>	from to	01.98
<b>Allocation</b>	Model Engine	Audi A4 1995 ➤ 2.7 ltr. - 184 kW bi-turbo
<b>Ratios:</b>	Final drive	37 : 9 = 4.111
<b>Z2 : Z1 = i</b>	1st gear	28 : 8 = 3.500
	2nd gear	34 : 18 = 1.889
	3rd gear	32 : 26 = 1.231
	4th gear	29 : 30 = 0.967
	5th gear	29 : 36 = 0.806
	6th gear	26 : 38 = 0.684
	Reverse gear	38 : 11 = 3.455

<b>Code letters</b>	<b>EDU</b>	
<b>Speedometer</b>	Electronic	
Capacity	2.3 liters <sup>1)</sup>	
<b>Specification</b>	Gear oil: SAE 75 W 90 (synthetic oil) Part number G 00 500 0	
<b>Clutch mechanism</b>	Hydraulic	
<b>Clutch plate diameter</b>	240 mm <sup>2)</sup>	
Drive shaft flange diameter	108 mm	
<b>Overall ratio iov in top gear</b>	2.813	
Allocation: rear final drive (code letters)	DQA	

<sup>1)</sup> With dual-mass flywheel