

Clutch, servicing

Special tools, testers and auxiliary items required

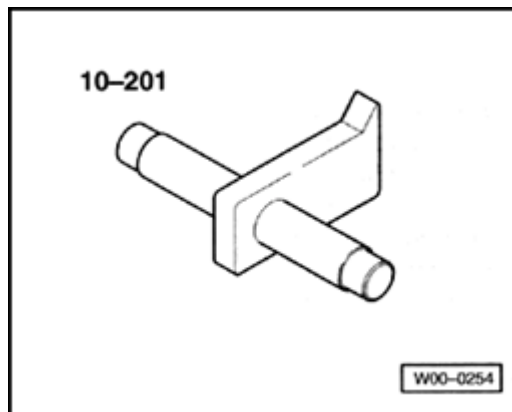

◆ Flywheel retainer 10-201

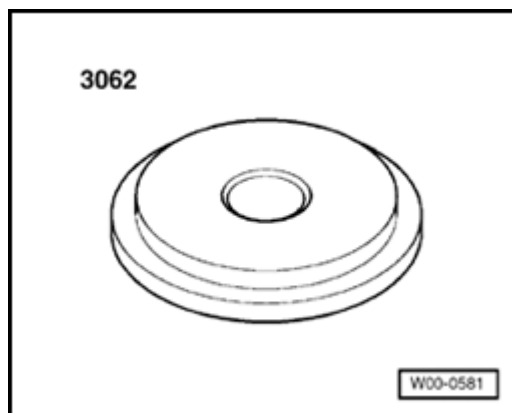

◆ Thrust pad 3062

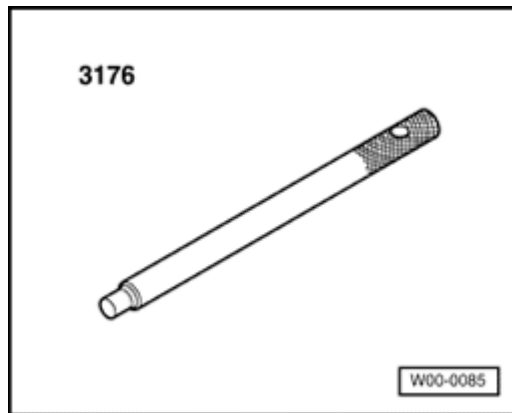

A

- ◆ Centering mandrel 3176
- ◆ Grease G 000 100

Notes:

- ◆ Observe general repair notes ⇒ [Page 00-11](#) .
- ◆ For vehicles with V6 2.7 L-Biturbo engine, a SAC-clutch plate (self adjusting clutch plate) is installed, on which an adjustment ring must be reset except during replacement ⇒ [Page 30-42](#) .
- ◆ Replace clutch plates and pressure plates with damaged or loose rivets.
- ◆ Select the correct clutch plate and pressure plate according to engine code:

⇒ Parts catalog

- ◆ Clean input shaft splines and (in the case of used clutch plates) the hub splines. Remove corrosion and apply only a very thin coating of grease G 000 100 to the splines. Then move clutch plate to and fro on input shaft until hub moves freely on shaft. Excess grease must be removed.
- ◆ Pressure plates have an anti-corrosion coating and are greased. Only the contact surface may be cleaned, otherwise the service life of the clutch will be considerably reduced.
- ◆ If the clutch has burned out, thoroughly clean the bellhousing, flywheel and parts of the engine facing the transmission to reduce the smell of burned linings.

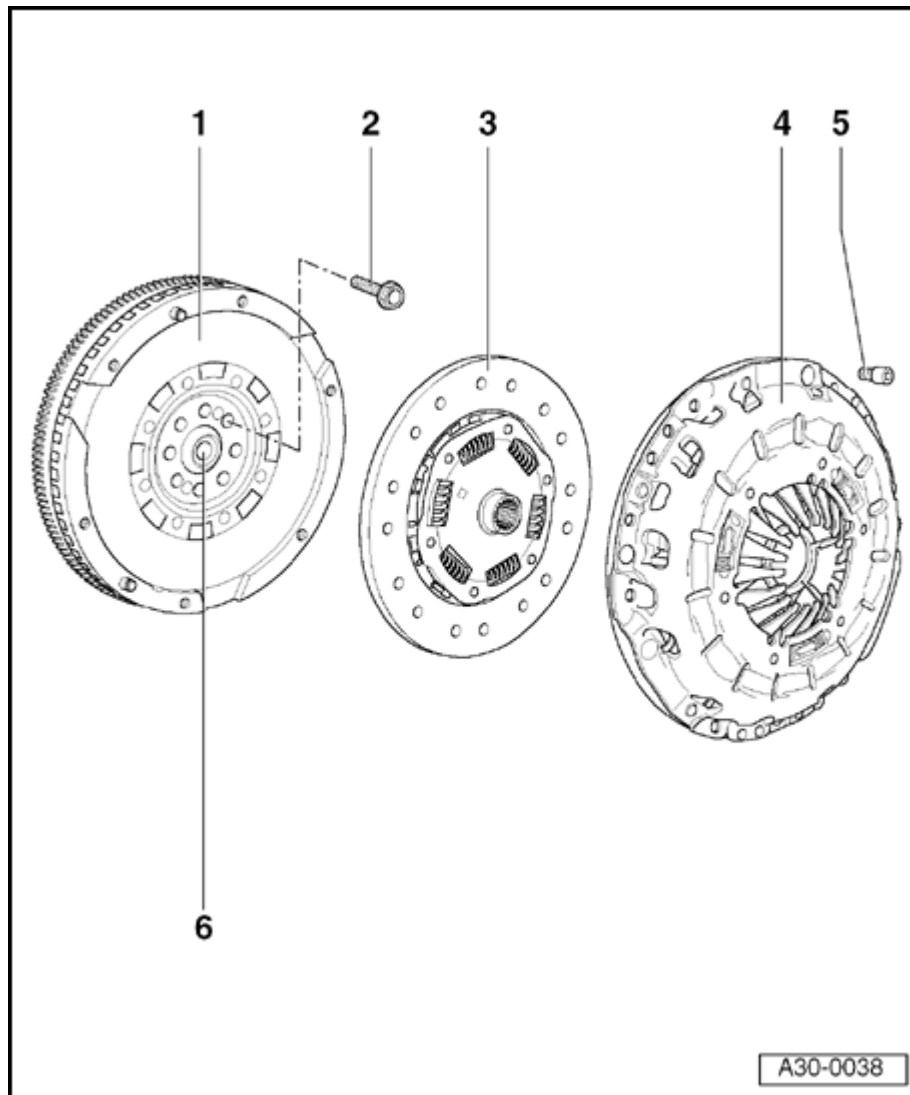

Clutch (SAC pressure plate) for vehicles with 6-cylinder 2.7 liter bi-turbo engine

Before working on the clutch, the transmission must be removed ⇒ [Page 34-18](#) .

1 - Dual-mass flywheel

- ◆ Ensure centering pins are tightly seated
- ◆ Contact surface for clutch lining must be free of grooves, oil and grease
- ◆ Removing and installing

⇒ [Repair Manual, 2.7 Liter V6 5V BiTurbo Engine Mechanical, Engine Code\(s\): APB, Repair Group 13](#)

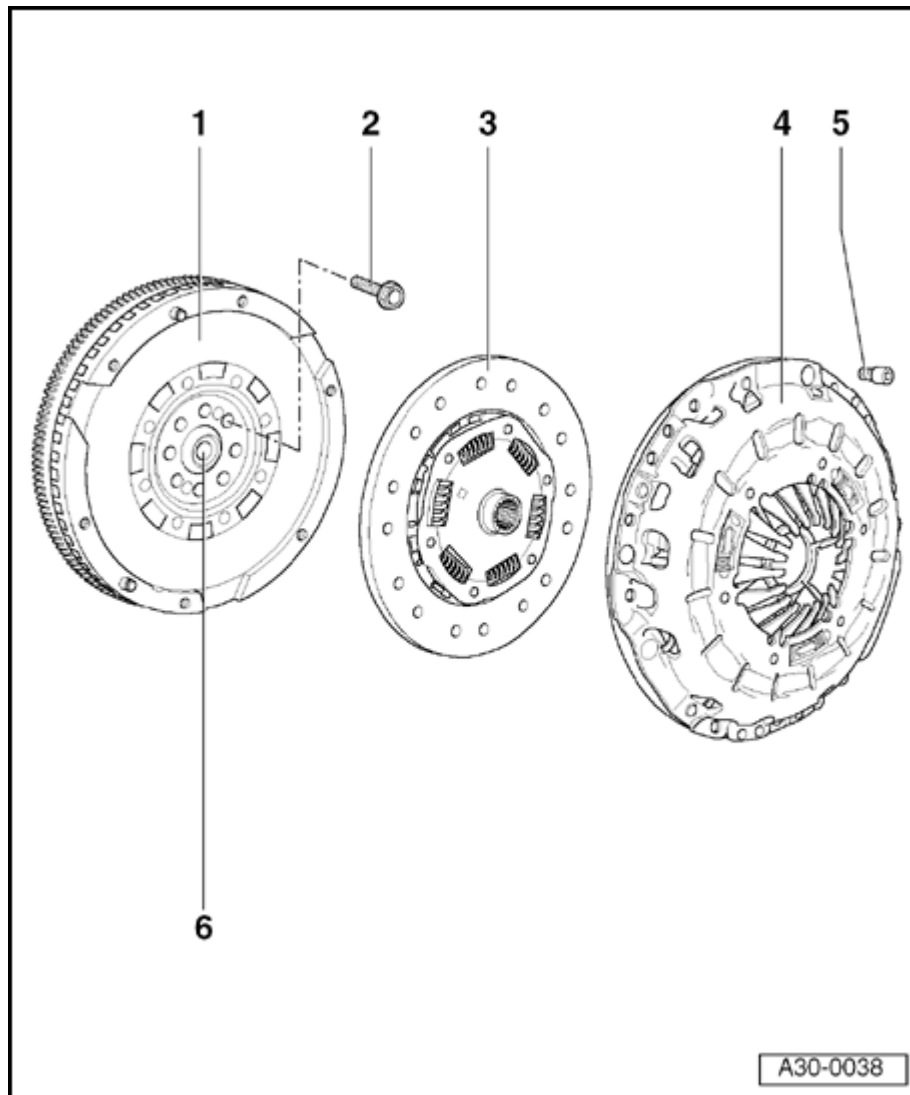

2 - Bolt

- ◆ Vehicles with dual-mass flywheel: tighten bolt to 60 Nm, then turn a further 180°
- ◆ Always replace

⇒ [Repair Manual, 2.7 Liter V6 5V BiTurbo Engine Mechanical, Engine Code\(s\): APB, Repair Group 13](#)

3 - Clutch plate

- ◆ Install with spring pack (coil springs) or the word "Getriebeseite" towards pressure plate and transmission
- ◆ Centering ⇒ [Page 30-45](#)
- ◆ Do not grease
- ◆ Clutch plate diameter ⇒ [from Page 00-3](#)

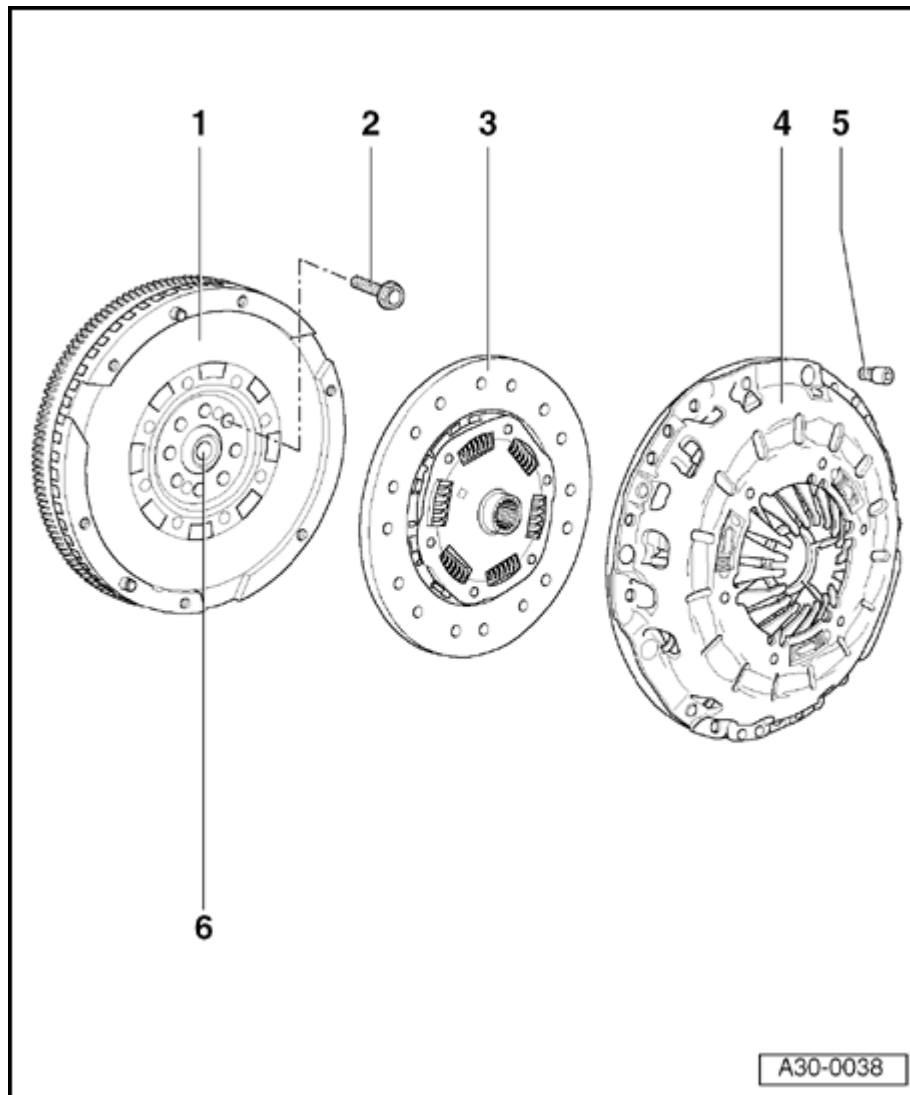

4 - SAC pressure plate

- ◆ Removing and installing ⇒ [Page 30-45](#)
- ◆ Resetting adjuster ring ⇒ [Page 30-42](#)
- ◆ Checking ends of diaphragm spring ⇒ [Fig. 1](#)
- ◆ Checking spring connection and riveted fastenings

5 - Bolt, 22 Nm

- ◆ Tighten gradually in diagonal sequence and in several stages

6 - Needle roller bearing

- ◆ Removing and installing

⇒ [Repair Manual, 2.7 Liter V6 5V BiTurbo Engine Mechanical, Engine Code\(s\): APB, Repair Group 13](#)

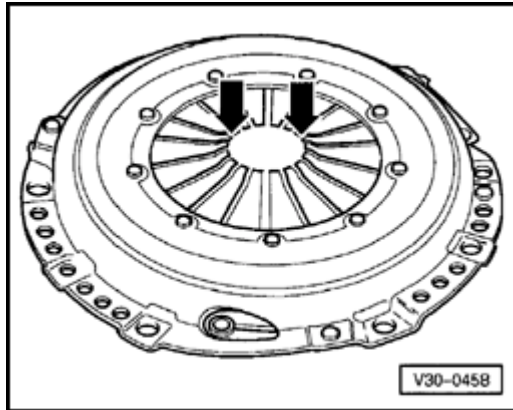

A

Fig. 1 Checking ends of diaphragm springs

- ◆ Wear up to half of the diaphragm spring thickness is permissible
- Check diaphragm springs and spring connection between pressure plate and cover for cracks, rivet connections and for secure fit.
- Replace clutches with damaged springs or with loose rivet connections (arrows).

Note:

In case of repair, always allocate clutch pressure plate and clutch disc to engine code according to to parts catalog.

Adjuster ring in SAC clutch pressure plate, resetting

- ◆ "SAC" stands for Self-Adjusting-Clutch
- ◆ When fitting a new clutch plate together with a used SAC pressure plate, the adjuster ring in the pressure plate has to be reset by turning it back as far as it will go. If this is not done, the SAC pressure plate will operate with reduced clamping force, which will cause clutch slip and excessive wear (especially of the clutch plate). This adjustment is only required when fitting a new clutch plate together with a used SAC pressure plate, as above.
- ◆ If the clutch plate is not being replaced, it is not necessary to reset the adjuster ring.
- ◆ New SAC pressure plates are pre-set accordingly, and do not have to be reset.

30-43

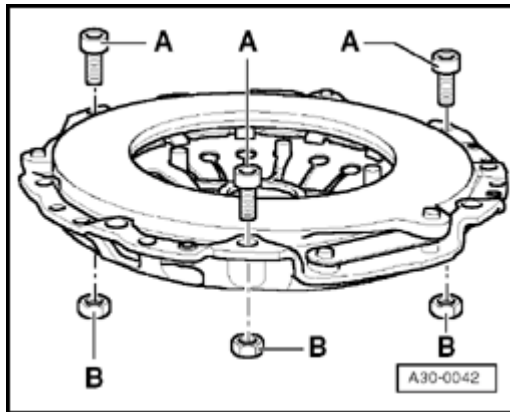

A

- Insert 3 securing bolts -A- into mounting holes on pressure plate, 120° from each other (1/3 turn), as shown in illustration.
- Thread 3 nuts -B- (M8) onto bolts -A- and tighten nuts slightly.

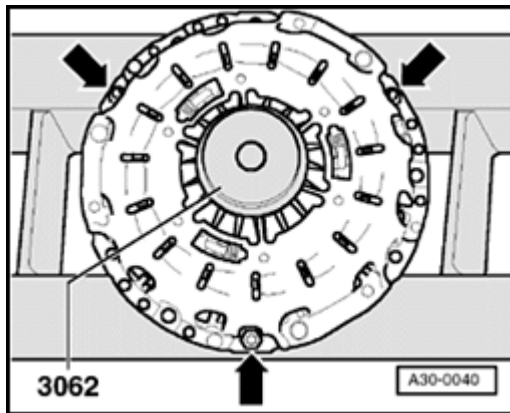

A

- Place SAC pressure plate onto press so that only the 3 bolt heads (arrows) make contact.
- Position special tool 3062 in center of pressure plate.

30-44

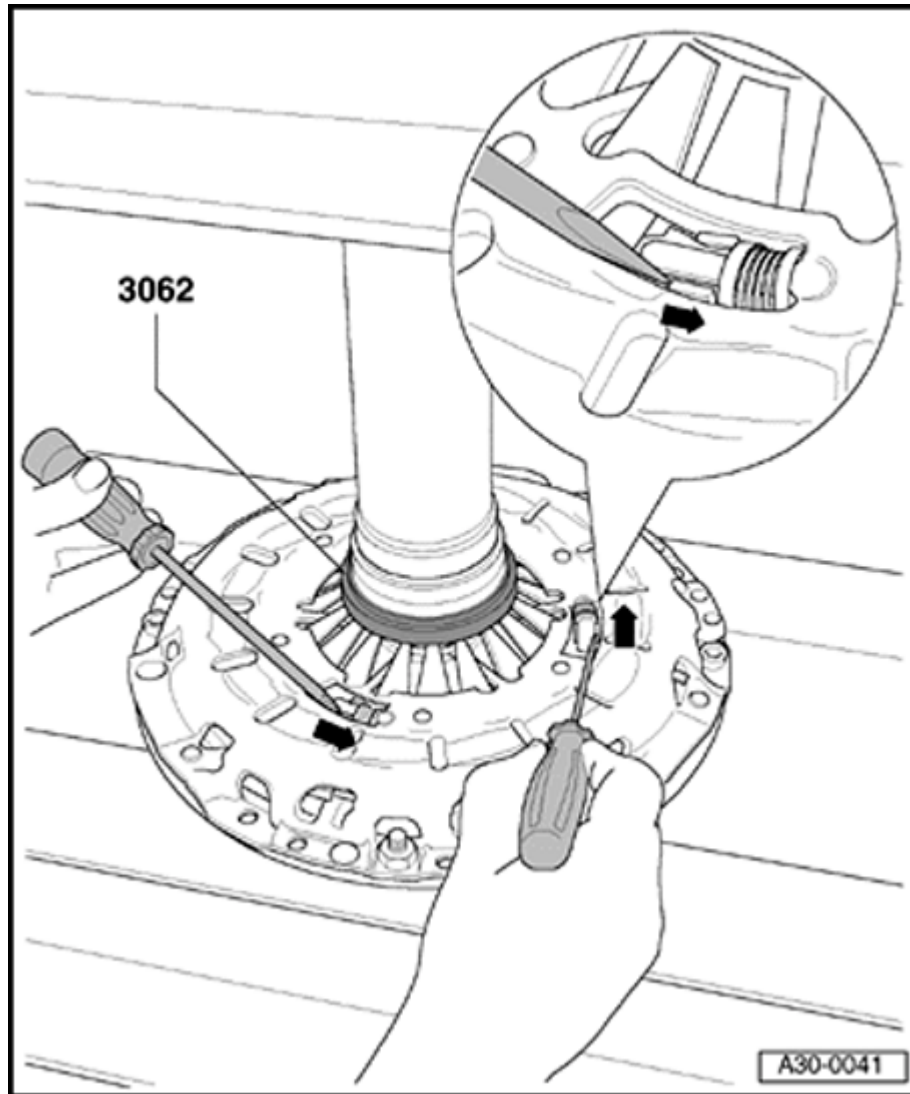

Do not use force when performing the following steps, otherwise the forks on the adjuster ring can break off.

- Apply two screwdrivers to forks on adjuster ring. Use press to compress pressure plate until it is just possible to move adjuster ring.
- Using two screwdrivers, turn back adjuster ring evenly in direction of arrows until it reaches stop.
- Hold adjuster ring against stop and reduce pressure exerted by press so that adjuster ring is held in this position.

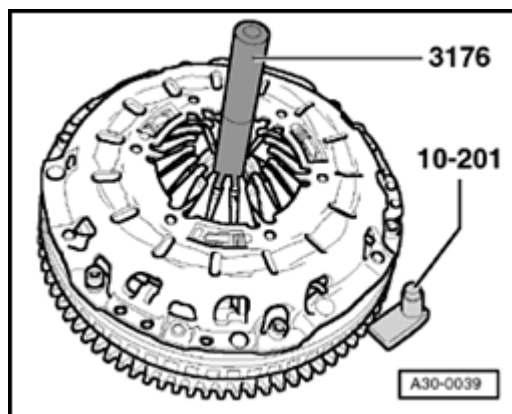

▲ Removing and installing clutch with SAC pressure plate

Note:

- ◆ *The adjuster ring in the SAC pressure plate has to be reset (⇒ [Page 30-42](#)) before assembly when replacing the clutch plate on its own.*
 - ◆ *Clutch lining and contact surface of pressure plate must make full contact with flywheel before securing bolts are inserted.*
 - ◆ *To avoid damaging centering holes in pressure plate and centering pins on flywheel, tighten securing bolts evenly and in several stages in diagonal sequence.*
- Position of clutch plate: spring pack (coil springs) or marking "Getriebeseite" towards pressure plate and transmission.
 - Loosen and tighten bolts gradually in diagonal sequence and in several stages to 22 Nm.
 - Reverse position of counter-hold tool 10-201 when removing.
 - Use mandrel 3176 to center clutch plate.