

## Input shaft, adjusting

### Note:

*The input shaft must be re-adjusted if the transmission housing, input shaft or ball bearing is replaced.*

### Special tools and equipment

- ◆ 30-100 press tube
- ◆ 3167 spacer gauge
- ◆ Depth gauge

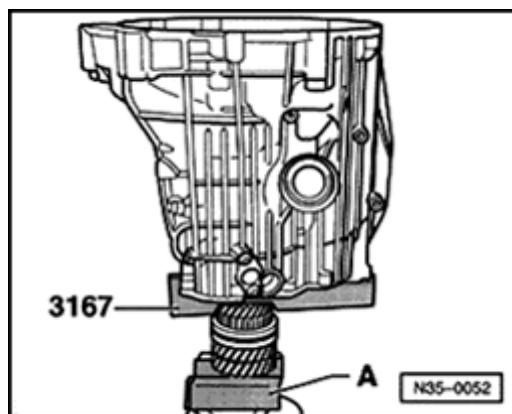

A

- Clamp input shaft in vice using protective jaws -A-.
- Place 3167 spacer gauge onto 3rd gear.
- Place transmission housing over input shaft onto spacer gauge.

### Calculating dimension -x-



A

- Place depth gauge onto transmission housing and measure to lower circlip groove of input shaft.

Dimension in the example: -a- = 28.50 mm (1.122 in.)

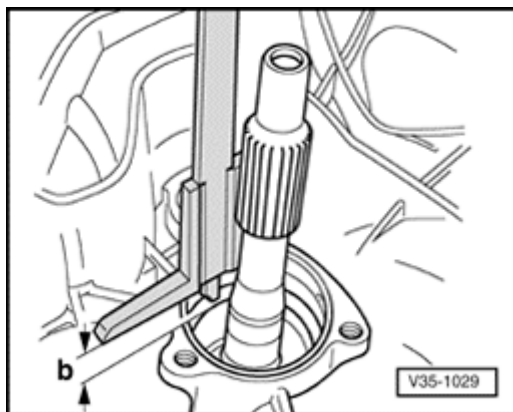

A

- Place depth gauge onto transmission housing and measure to seating surface for ball bearing.

Measurement in the following example: -b- = 26.80 mm (1.055 in.)

### Determining circlip thickness behind the input shaft ball bearing

#### Formula:

$$x = a - b$$

#### Example:

- |  |          |
|--|----------|
| Dimension -a-                          | 28.50 mm |
| - Dimension -b-                        | 26.80 mm |
| = Dimension -x- (thickness of circlip) | 1.70 mm  |
- Determine circlip thickness according to table ⇒ [Page 35-19](#) .
  - For part number ⇒ parts catalog

**Available circlips**

<b>Dimension -x- (mm)</b>	<b>Thickness (mm)</b>
1.48 - 1.56	1.54
1.57 - 1.65	1.63
1.66 - 1.74	1.72
1.75 - 1.83	1.81
1.84 - 1.92	1.90
1.93 - 2.01	1.99
2.02 - 2.10	2.08
2.11 - 2.20	2.17

### Determining circlip thickness in front of input shaft ball bearing

- Drive rear circlip (as calculated) and ball bearing onto input shaft using 30-100 press tube.

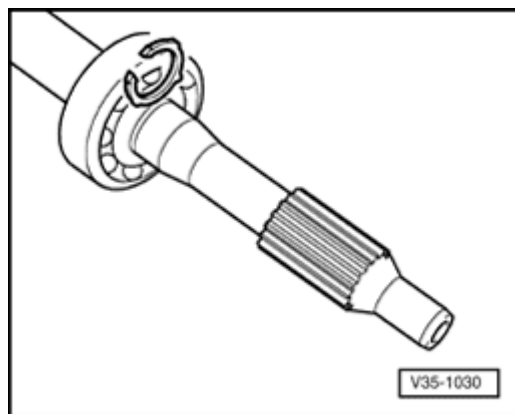

A

- Determine thickest circlip which can still just be installed.
- Determine circlip thickness according to table.

Part number ⇒ parts catalog

### Available circlips

Circlip thickness (mm)		
1.45	1.72	1.99
1.54	1.81	2.08
1.63	1.90	2.17