

## Transmission, identification

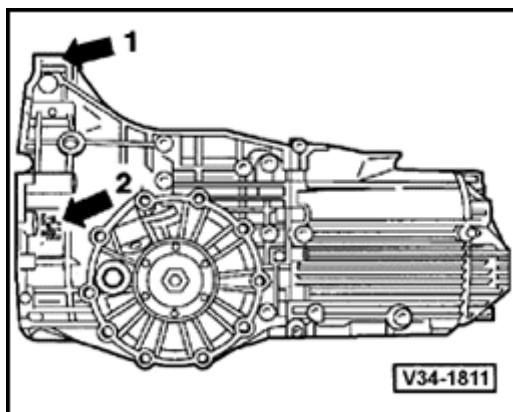

### Location on transmission

- ◆ Code letters and date of manufacture (arrow -1-)
- ◆ Manual transmission 012/01W (arrow -2-)

#### **Note:**

*For organizational reasons, code "012" has been expanded to include code "01W." Both codes refer to the same transmission type.*

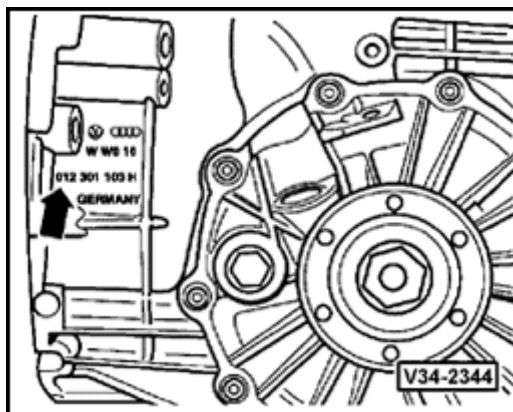

### Manual transmission 012/01W (arrow -2-)

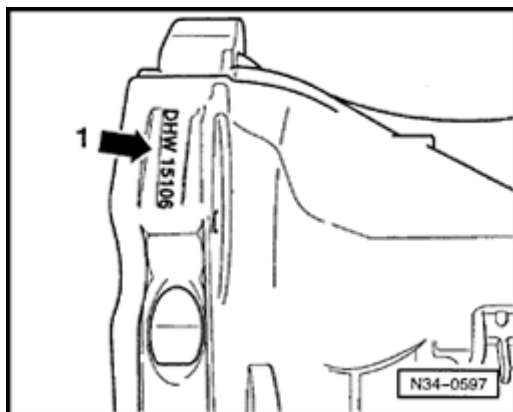

**A Transmission code letters and date of manufacture (arrow -1-)**

<b>Example:</b>	<b>DHW</b>	<b>15</b>	<b>10</b>	<b>6</b>
	Code letters	Day	Month	Year (1996) of manufacture

Additional information depends on manufacturing.

**Note:**

*The transmission code letters are also listed on the vehicle data plates.*

### Code letters, transmission application, ratios, capacities

Manual transmission		5-speed 012 front wheel drive			
Code letters		CTE	DHW 1)	CTJ	CWY
<b>Manufactured</b>	from	11.94	07.96	11.94	11.94
	to	07.96		03.95	03.95
<b>Application</b>	Model	<b>Audi A4 1996 ➤</b>	<b>Audi A4 1996 ➤</b>	<b>Audi A4 1996 ➤</b>	<b>Audi A4 1996 ➤</b>
	Engine	1.8 L - 110 kW (150 hp)	1.8 L - 110 kW (150 hp)	2.8 L - 128 kW (172 hp)	2.8 L - 128 kW (172 hp)
<b>Ratio:</b> Z2 : Z1 = i	Final drive	37 : 10 = 3.700	37 : 10 = 3.700	37 : 10 = 3.700	37 : 10 = 3.700
	1st Gear	35 : 10 = 3.500	35 : 10 = 3.500	35 : 10 = 3.500	35 : 10 = 3.500
	2nd Gear	36 : 17 = 2.118	36 : 17 = 2.118	35 : 19 = 1.842	35 : 18 = 1.944
	3rd Gear	39 : 30 = 1.300	39 : 30 = 1.300	39 : 30 = 1.300	39 : 30 = 1.300
	4th Gear	35 : 34 = 1.029	35 : 34 = 1.029	33 : 35 = 0.943	33 : 35 = 0.943
	5th Gear	31 : 37 = 0.838	31 : 37 = 0.838	30 : 38 = 0.789	30 : 38 = 0.789
	Reverse Gear	31 : 9 = 3.444	31 : 9 = 3.444	31 : 9 = 3.444	31 : 9 = 3.444
1) Modified transmission housing; transmission code DHW replaces CTE.					

00-4

<b>Code letters</b>	<b>CTE</b>	<b>DHW 1)</b>	<b>CTJ</b>	<b>CWY</b>
<b>Speedometer</b>	electronic			
<b>Capacity</b>	2.25 liters (2.38 qts.)			
<b>Specification</b>	Gear oil: SAE 75 W 90 (synthetic oil) Part number G 005 000 (1 liter)			
<b>Clutch control</b>	hydraulic	hydraulic	hydraulic	hydraulic
Clutch plate diameter	228 mm	228 mm	240 mm	240 mm
<b>Drive shaft flange diameter</b>	108 mm	108 mm	130 mm 2)	130 mm 2)
<b>Polygon bearing</b>	Yes	Yes	no	no
<b>Overall ratio in high gear</b>	3.100	3.100	2.921	2.921
2) Drive axle with triple rotor joint.				

<b>Manual transmission</b>		<b>5-speed 012/01W front wheel drive</b>			
<b>Code letters</b>		<b>CWZ</b>	<b>DHX 3)</b>	<b>DDK</b>	<b>DHY 4)</b>
<b>Manufactured</b>	from	01.95	07.96	03.96	07.96
	to	07.96		07.96	
<b>Application</b>	Model	<b>Audi A4 1996 ➤</b>	<b>Audi A4 1996 ➤</b>	<b>Audi A4 1996 ➤</b>	<b>Audi A4 1996 ➤</b>
	Engine	2.8 L - 128 kW (172 hp)	2.8 L - 128 kW (172 hp)	2.8 L - 142 kW (191 hp)	2.8 L - 142 kW (191 hp)
<b>Ratio:</b> Z2 : Z1 = i	Final drive	37 : 10 = 3.700	37 : 10 = 3.700	37 : 10 = 3.700	37 : 10 = 3.700
	1st Gear	35 : 10 = 3.500	35 : 10 = 3.500	35 : 10 = 3.500	35 : 10 = 3.500
	2nd Gear	35 : 18 = 1.944	35 : 18 = 1.944	35 : 18 = 1.944	35 : 18 = 1.944
	3rd Gear	39 : 30 = 1.300	39 : 30 = 1.300	39 : 30 = 1.300	39 : 30 = 1.300
	4th Gear	33 : 35 = 0.943	33 : 35 = 0.943	33 : 35 = 0.943	33 : 35 = 0.943
	5th Gear	30 : 38 = 0.789	30 : 38 = 0.789	30 : 38 = 0.789	30 : 38 = 0.789
	Reverse Gear	31 : 9 = 3.444	31 : 9 = 3.444	31 : 9 = 3.444	31 : 9 = 3.444
3) Modified transmission housing; transmission code DHX replaces CWZ.					
4) Modified transmission housing; transmission code DHY replaces DDK.					

<b>Code letters</b>	<b>CWZ</b>	<b>DHX 3)</b>	<b>DDK</b>	<b>DHY 4)</b>
<b>Speedometer</b>	electronic			
<b>Capacity</b>	2.25 liters (2.38 qts.)			
<b>Specification</b>	Gear oil: SAE 75 W 90 (synthetic oil) Part number G 005 000 (1 liter)			
<b>Clutch control</b>	hydraulic	hydraulic	hydraulic	hydraulic
Clutch plate diameter	240 mm	240 mm	240 mm	240 mm
<b>Drive shaft flange diameter</b>	130 mm 2)	130 mm 2)	130 mm 2)	130 mm 2)
<b>Polygon bearing</b>	Yes	Yes	Yes	Yes
<b>Overall ratio in high gear</b>	2.921	2.921	2.921	2.921
<p>2) Drive axle with triple rotor joint.</p> <p>3) Modified transmission housing; transmission code DHX replaces CWZ.</p> <p>4) Modified transmission housing; transmission code DHY replaces DDK.</p>				