

Gear oil in front final drive

Gear oil in front final drive, checking

Special tools and equipment

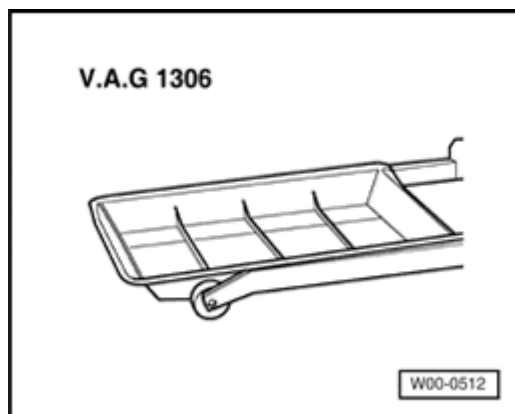

A

- ◆ VAG1306 drip tray

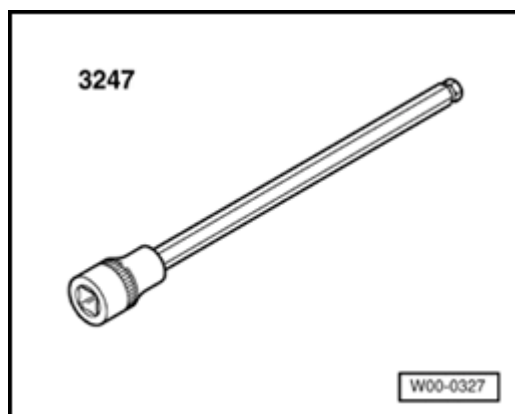

A

- ◆ 3247 plug insert (8mm)
 - Perform a short road test to heat up gear oil to approx. 60 ° C.
 - Drive the vehicle onto a 4-column lift or over a work pit so that it is absolutely level.
 - Switch engine off and let gear oil drip out for 5 minutes.
 - Place VAG1306 drip tray underneath.

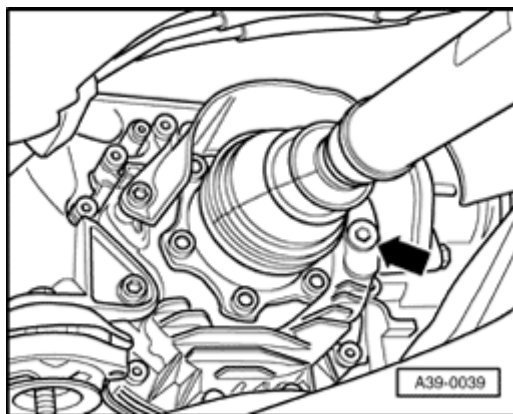

- A
- Remove oil filler plug (arrow).

Note:

Loosen locking bolt using an angled socket-head wrench, but do not use 3247 hex ball socket. For improved accessibility it may be necessary to remove the heat shield and drive axle and to set them aside.

If 3247 hex ball socket is used for loosening the bolt, it could be destroyed.

- ◆ Specification: Oil level should reach lower edge of oil filler hole.
- Let excessive gear oil drain or top up gear oil.
 - ◆ Specification ⇒ [page 00-22](#)
- Always replace O-ring for oil filler plug.
- Tighten locking bolt using 3247 hex ball socket (8mm socket) to 30 Nm.

Gear oil in front final drive, filling up after repair

Special tools and equipment

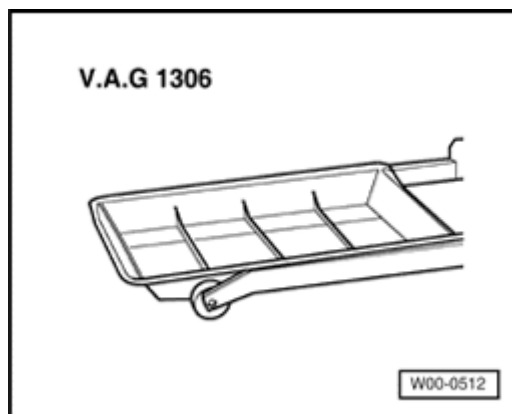

A

◆ VAG1306 drip tray

- Drive the vehicle onto a 4-column lift or over a work pit so that it is absolutely level.
- Place VAG1306 drip tray underneath.

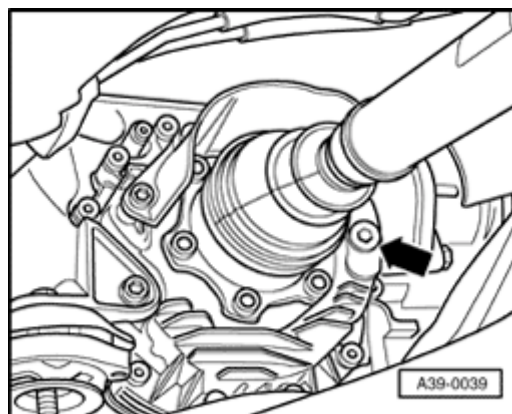

A

- Remove oil filler plug (arrow).

Note:

Loosen locking bolt using an angled socket-head wrench, but do not use 3247 hex ball socket. For improved accessibility it may be necessary to remove the heat shield and drive axle and to set them aside.

If 3247 hex ball socket is used for loosening the bolt, it could be destroyed.

- Slowly and uniformly fill front final drive over a time period of at least 5 minutes until gear oil escapes at lower edge of oil filler hole.

◆ Specification ⇒ [page 00-22](#)

Note:

Filling time of at least 5 minutes is essential, so that the internal oil level compensation between differential and retaining area can occur.

- Install old oil filler plug.
- Perform a short road test to heat up gear oil to approx. 60 ° C.
- Make sure to check oil level in front final drive ⇒ [page 39-1](#) !