

Motronic fuel injection system, servicing

Safety precautions

If special testing equipment is required during road test, note the following:

WARNING!

- ◆ ***Test equipment must always be secured to the rear seat and operated from there by a second person.***
- ◆ ***If test and measuring equipment is operated from the passenger seat, the person seated there could be injured in the event of an accident involving deployment of the passenger-side airbag.***

To reduce the risk of personal injury and/or damage to the fuel injection and ignition system, always observe the following:

- ◆ Only disconnect and reconnect wires for injection and ignition system, including test leads, when ignition is turned off.
- ◆ If engine is to be cranked at starting RPM without starting (e.g. for compression testing),

disconnect connector from ignition coils and
from fuel injectors.

- ◆ It is possible that the control module will recognize a malfunction and store a DTC during some tests. After completing all tests and repairs, DTC memory should therefore be checked and erased if necessary. Readiness code must be generated after DTC memory is erased ⇒ [Page 01-73](#) .
- ◆ Always switch ignition off before cleaning engine.
- ◆ The battery should only be disconnected and reconnected when the ignition is turned off, since otherwise the Engine Control Module (ECM) can be damaged.

WARNING!

Fuel system is under pressure! Before opening system, place rags around the connection point. Then release pressure by carefully loosening connection.

Rules of cleanliness

When working on the fuel supply or fuel injection systems, the following "6 rules of cleanliness" should be carefully observed:

- ◆ Thoroughly clean all connections and the surrounding area before disconnecting.
- ◆ Place parts that have been removed on a clean surface and cover. Use lint-free cloths only!
- ◆ Carefully cover over opened components or seal, if repairs are not carried out immediately.
- ◆ Only install clean components: Only unpack replacement parts immediately prior to installation. Do not use parts that have been stored loose (in tool boxes etc.)
- ◆ When the system is open: Do not work with compressed air if it can be avoided. Do not move vehicle unless absolutely necessary.
- ◆ Disconnected electrical harness connectors: Protect from dirt and moisture. Be sure harness connector is dry before connecting.

Technical data

Engine identification		ATW (1.8 L / 5V/ 110 kW-engine)
Idle speed		
Engine speed cannot be adjusted, it is regulated by idle stabilization	Front Wheel Drive (FWD)	740 to 860 RPM
	All Wheel Drive (AWD)	800 to 920 RPM
Engine speed (RPM) limitation via fuel injector shut-off		about 6800 RPM
Fuel pressure at idle speed	Vacuum hose connected	about 3.5 bar positive pressure
	Vacuum hose disconnected	about 4.0 bar positive pressure
Residual pressure after 10 min.		at least 2.5 bar positive pressure
Fuel injectors	Injection stream	Dual-hole nozzle / same for all injectors
	Injection quantity (30 s)	135 ± 10 ml
	Resistance (room temperature)	12 to 13 Ω

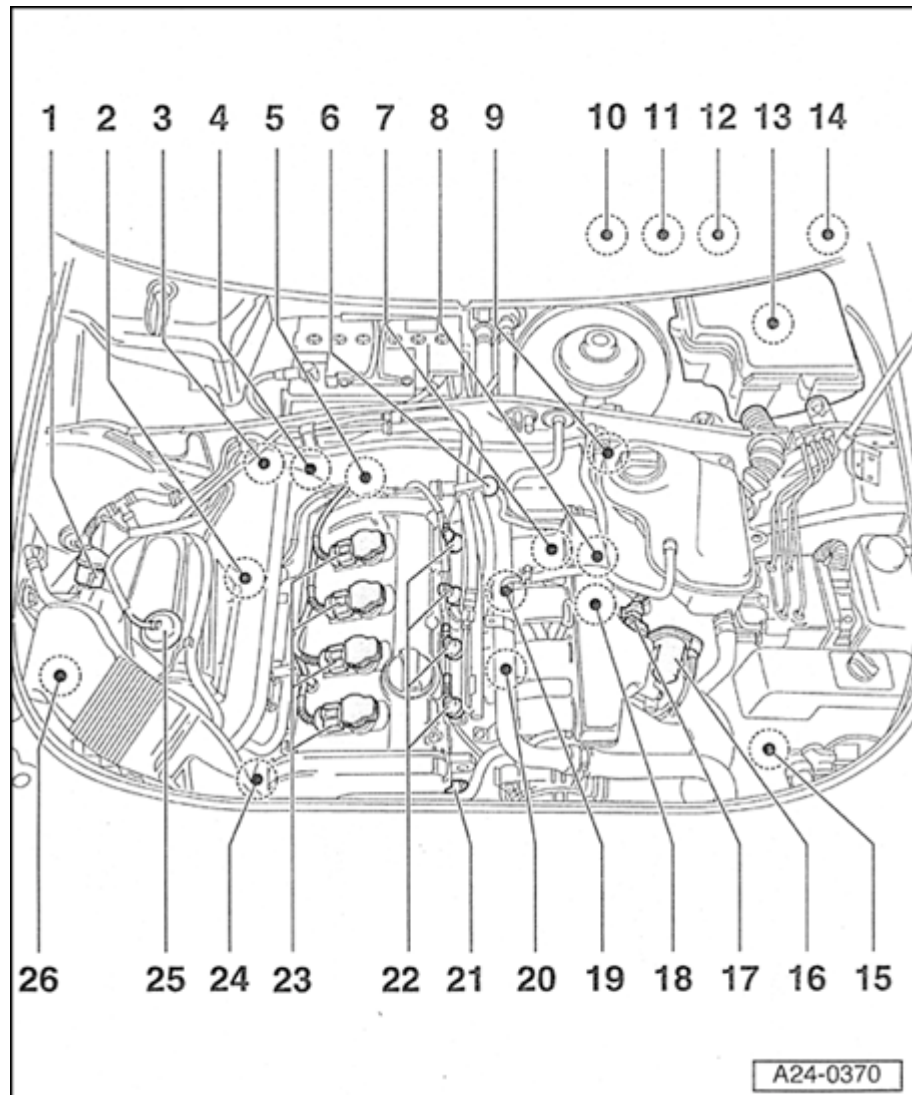

Component locations, overview

Note:

Component location without illustration:

---- - **Leak Detection Pump (LDP) -V144-**

◆ Behind rear left wheelhousing liner

1 - Evaporative Emission (EVAP) canister purge regulator valve -N80-

◆ Checking ⇒ [Page 24-107](#)

2 - Heated Oxygen Sensor (HO2S) -G39- before catalytic converter, 55 Nm

◆ Continuous oxygen sensor

◆ Check Oxygen Sensor (O2S) and oxygen sensor control before Three Way Catalytic Converter (TWC) ⇒ [Page 24-71](#)

◆ Check aging of oxygen sensor before catalytic converter ⇒ [Page 24-83](#)

◆ Check oxygen sensor heater for Oxygen Sensor (O2S) before Three Way Catalytic Converter (TWC) ⇒ [Page 24-99](#)

◆ Removing and installing ⇒ [Page 24-105](#)

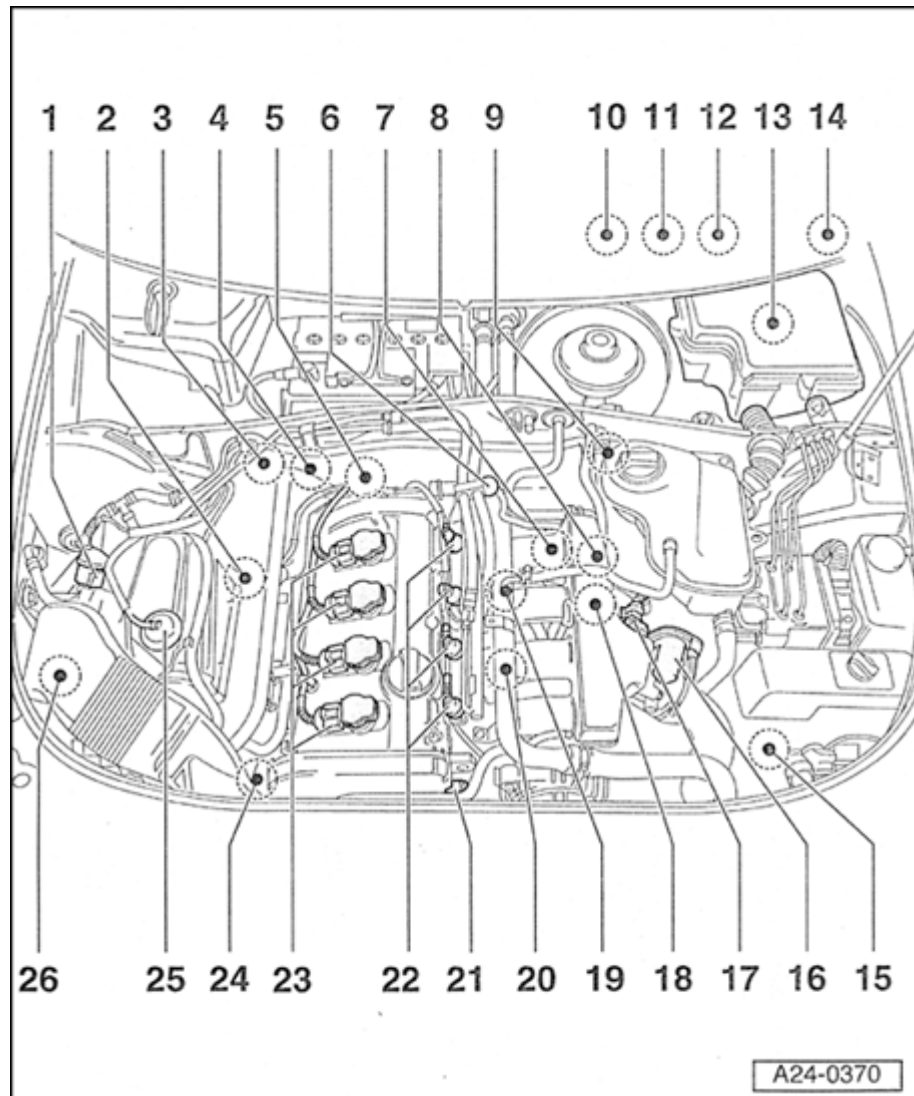

3 - Oxygen Sensor (O2S) behind Three Way Catalytic Converter (TWC) -G130-, 55 Nm

- ◆ Check Oxygen Sensor (O2S) and oxygen sensor control behind Three Way Catalytic Converter (TWC) ⇒ [Page 24-87](#)
- ◆ Check oxygen sensor heater for Oxygen Sensor (O2S) behind Three Way Catalytic Converter (TWC) ⇒ [Page 24-99](#)
- ◆ Removing and installing ⇒ [Page 24-105](#)

4 - Combination valve for secondary air injection (AIR)

- ◆ Checking, removing and installing:

⇒ [Repair Manual, 1.8 Liter 4-Cyl. 5V Turbo Engine Mechanical, Engine Code\(s\): AEB, ATW, Repair Group 26; Secondary Air Injection \(AIR\) system, checking](#)

5 - Engine Coolant Temperature (ECT) sensor -G62-

- ◆ Checking ⇒ [Page 28-30](#)

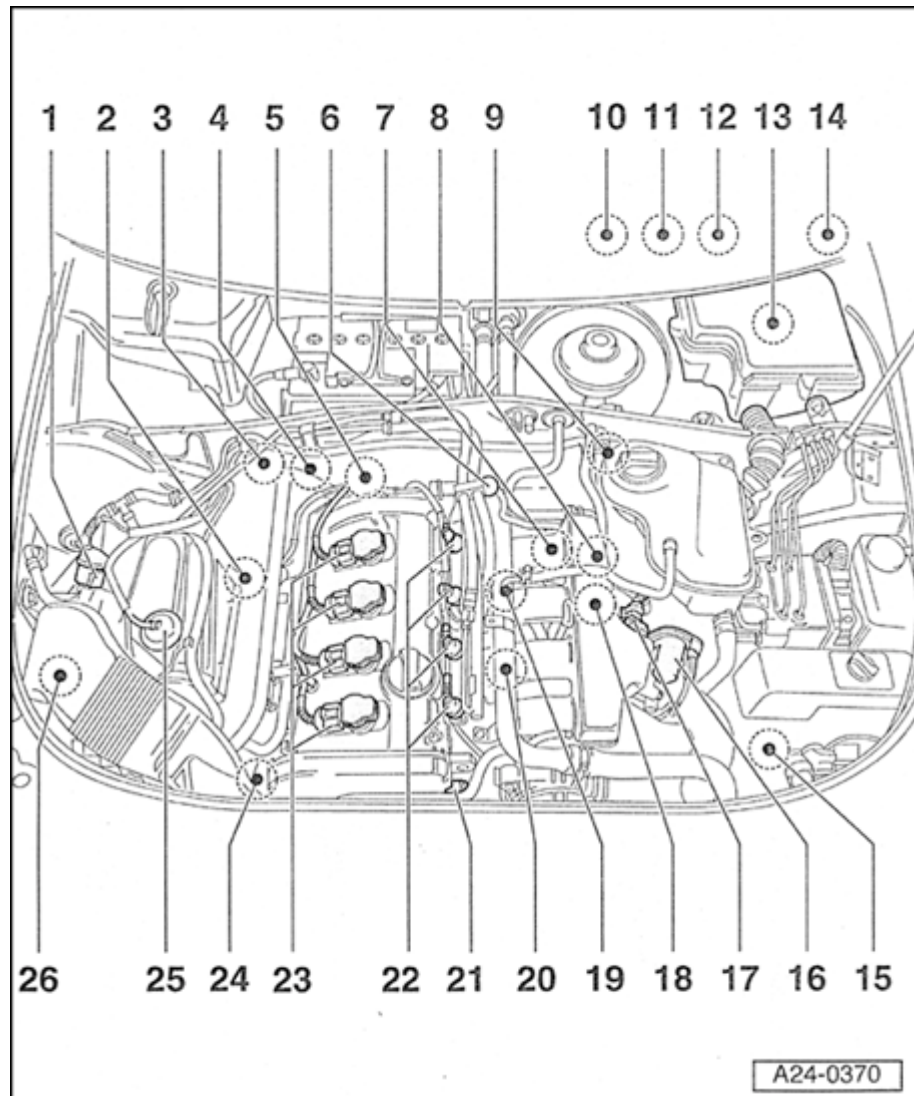

6 - Fuel pressure regulator

- ◆ Checking ⇒ [Page 24-33](#)

7 - Engine Speed (RPM) sensor -G28-

- ◆ Checking ⇒ [Page 28-26](#)

8 - Secondary Air Injection (AIR) solenoid valve-N112-

- ◆ Installation position ⇒ [Page 24-14](#) , Fig. ⇒ [4](#)
- ◆ Checking:

⇒ [Repair Manual, 1.8 Liter 4-Cyl. 5V Turbo Engine Mechanical, Engine Code\(s\): AEB, ATW, Repair Group 26; Secondary Air Injection \(AIR\) system, checking](#)

- ◆ Green harness connector

9 - Bracket for harness connectors

- ◆ Component location ⇒ [Page 24-13](#) , Fig. ⇒ [1](#)
- ◆ Accessible with coolant expansion tank unbolting and swung to the side.

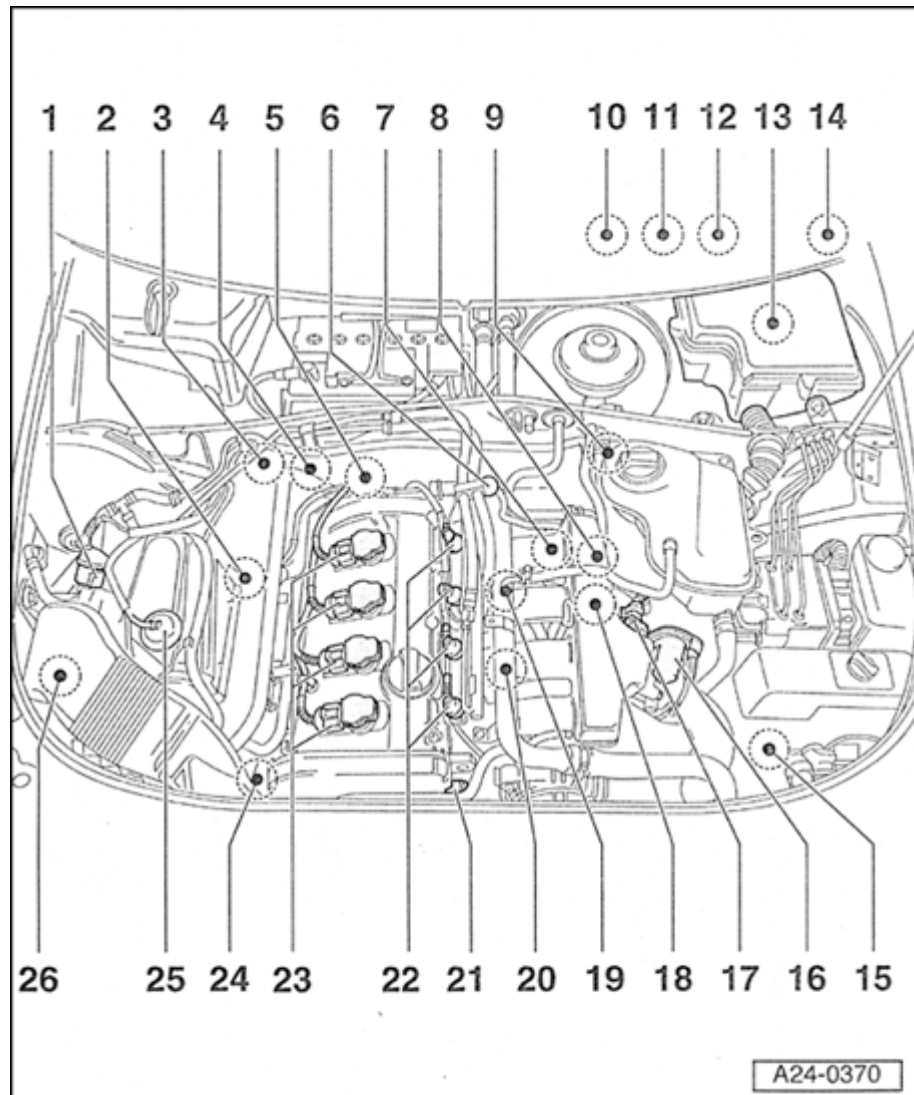

10 - Instrument cluster

- ◆ With exhaust Malfunction Indicator Lamp (MIL). Notes for Malfunction Indicator Lamp (MIL) ⇒ [Page 01-3](#)
- ◆ with fault light for power accelerator activation -K132- (EPC warning lamp). Significance of EPC warning lamp ⇒ [Page 24-115](#)

11 - Throttle Position (TP) sensor -G79- and sender 2 for accelerator pedal position -G185-

- ◆ Component location ⇒ [Page 24-15](#) , Fig. ⇒ [5](#)
- ◆ Checking ⇒ [Page 24-133](#)
- ◆ Adapt kick down function ⇒ [Page 24-139](#)

12 - Brake light switch -F- and brake pedal switch -F47-

- ◆ Component location ⇒ [Page 24-14](#) , Fig. ⇒ [3](#)

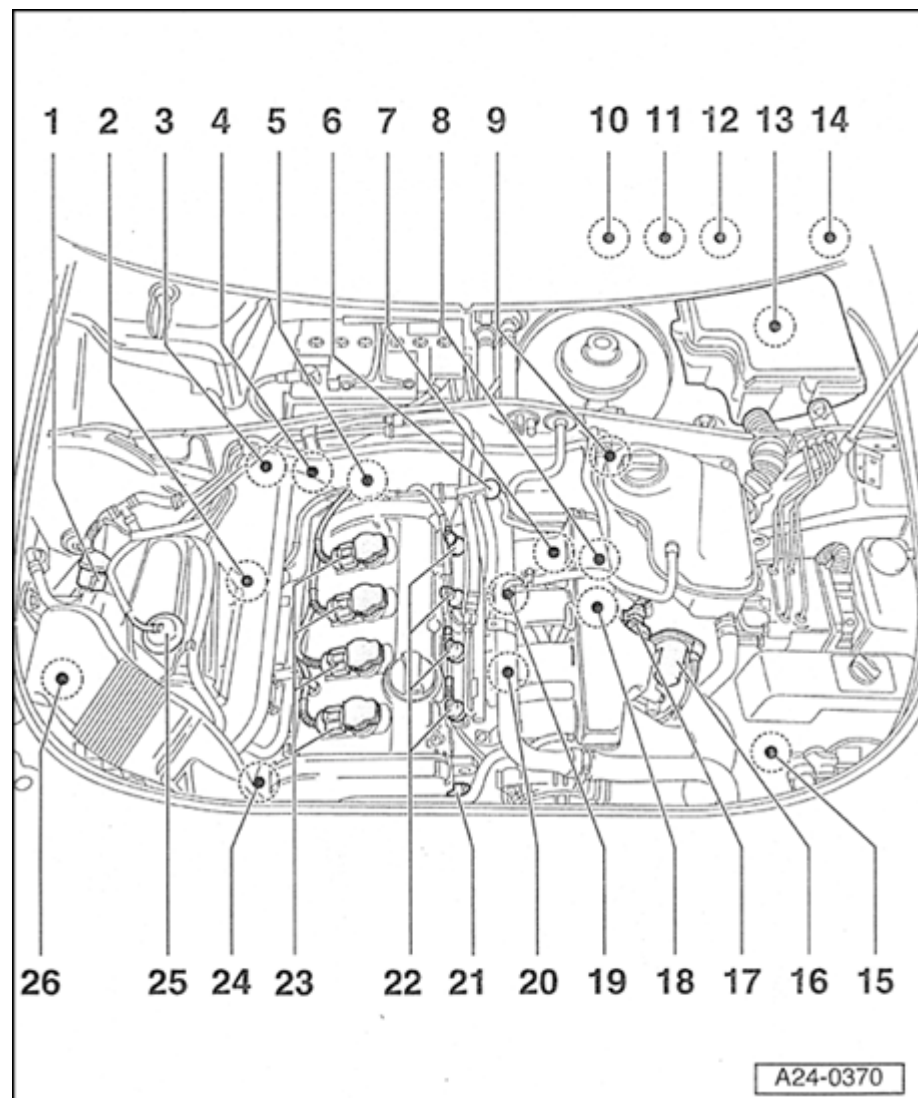

13 - E-box, plenum chamber

- ◆ Installation locations ⇒ [Page 24-15](#) , Fig. ⇒ [6](#)
- ◆ Installation location for motronic Engine Control Module (ECM) -J220- with integrated Barometric pressure (BARO) sensor -F96-
- ◆ Check voltage supply of Engine Control Module (ECM) ⇒ [Page 28-36](#)
- ◆ Procedure to follow after open circuit in voltage supply ⇒ [Page 24-22](#)
- ◆ Replacing Engine Control Module (ECM) ⇒ [Page 24-23](#)
- ◆ Installation location of Secondary Air Injection (AIR) pump relay -J299-
- ◆ Check Secondary Air Injection (AIR) pump relay -J299-:

⇒ [Repair Manual, 1.8 Liter 4-Cyl. 5V Turbo Engine Mechanical, Engine Code\(s\): AEB, ATW, Repair Group 26; Secondary Air Injection \(AIR\) system, checking](#)

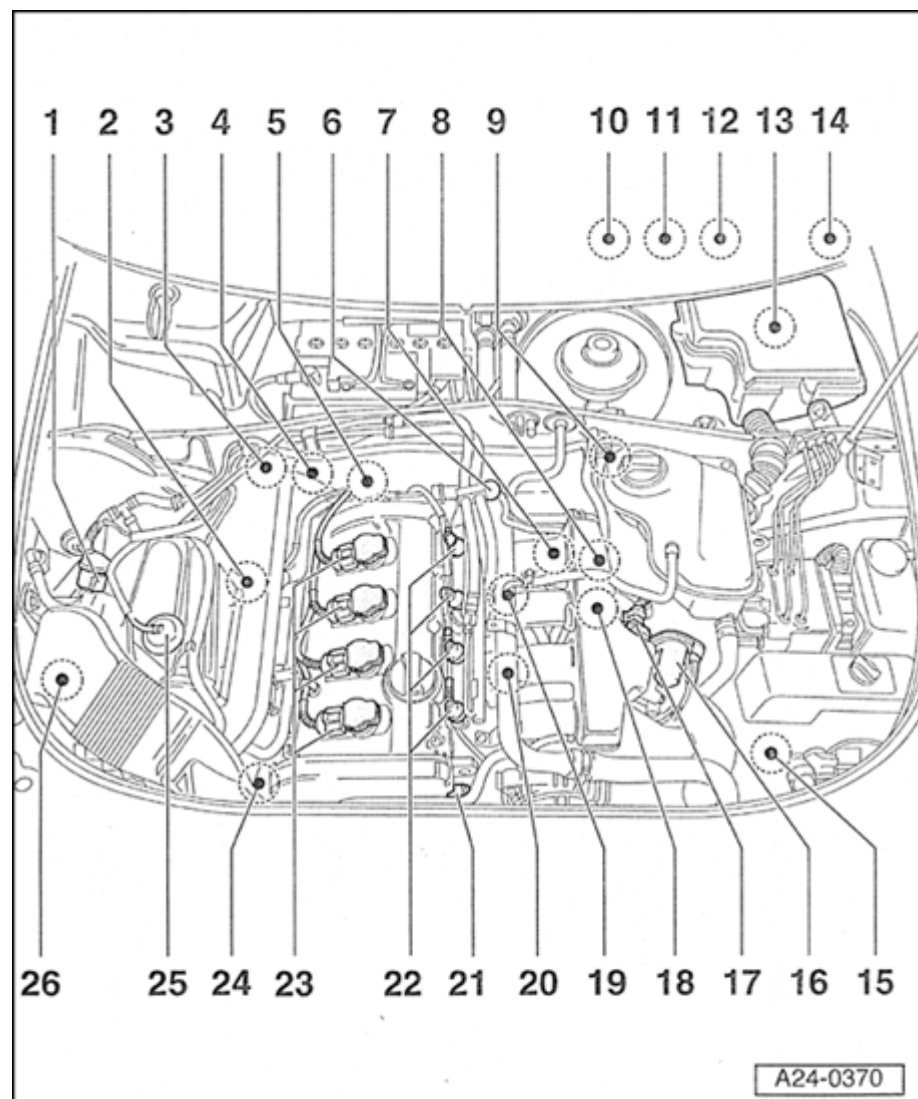

- ◆ Installation location of motronic Engine Control Module (ECM) power supply relay -J271-
- ◆ Check motronic Engine Control Module (ECM) power supply relay -J271- ⇒ [Page 28-13](#)
- ◆ Installation location of fuse S130 for Secondary Air Injection (AIR) pump
- 14 - Clutch vacuum vent valve switch -F36-**
 - ◆ Component location ⇒ [Page 24-14](#) , Fig. ⇒ [3](#)
- 15 - Charge air pressure sensor -G31-**
 - ◆ Installation position ⇒ [Page 24-16](#) , Fig. ⇒ [7](#)
 - ◆ Checking:

⇒ [Repair Manual, 1.8 Liter 4-Cyl. 5V Turbo Engine Mechanical, Engine Code\(s\): AEB, ATW, Repair Group 21, Charge air system with turbocharger, checking](#)

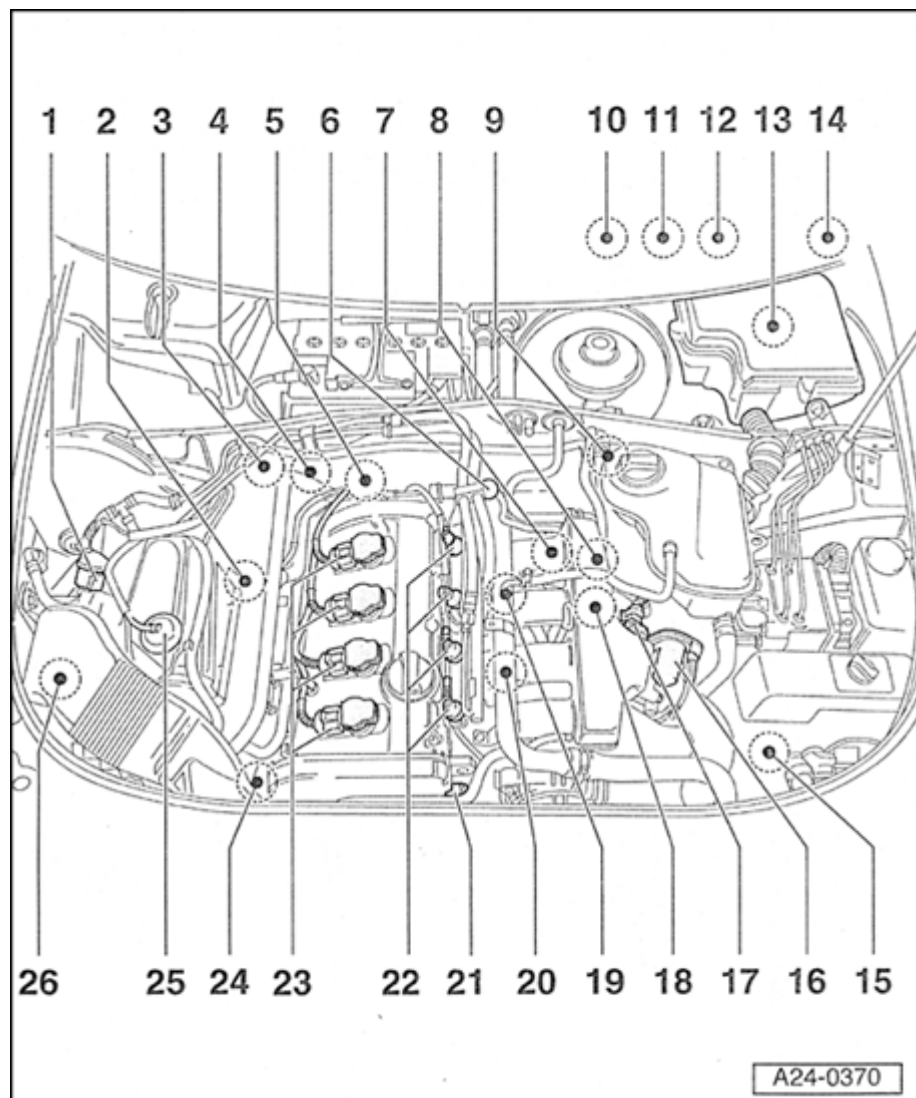

16 - Throttle valve control module -J338-

- ◆ With throttle drive (power accelerator actuation) -G186-, angle sensor -1- for throttle drive (power accelerator actuation) -G187-, and angle sensor -2- for throttle drive (power accelerator actuation) -G188-
- ◆ Checking ⇒ [Page 24-120](#)

17 - Intake Air Temperature (IAT) sensor -G42-

- ◆ Checking ⇒ [Page 28-21](#)

18 - Recirculating valve for turbocharger-N249-

- ◆ Installation position ⇒ [Page 24-14](#) , Fig. ⇒ [4](#)
- ◆ Blue harness connector

19 - Knock Sensor (KS) 1 -G61-

20 - Knock Sensor (KS) 2 -G66-

21 - Camshaft Position (CMP) sensor 2 -G40-

- ◆ Checking ⇒ [Page 28-45](#)

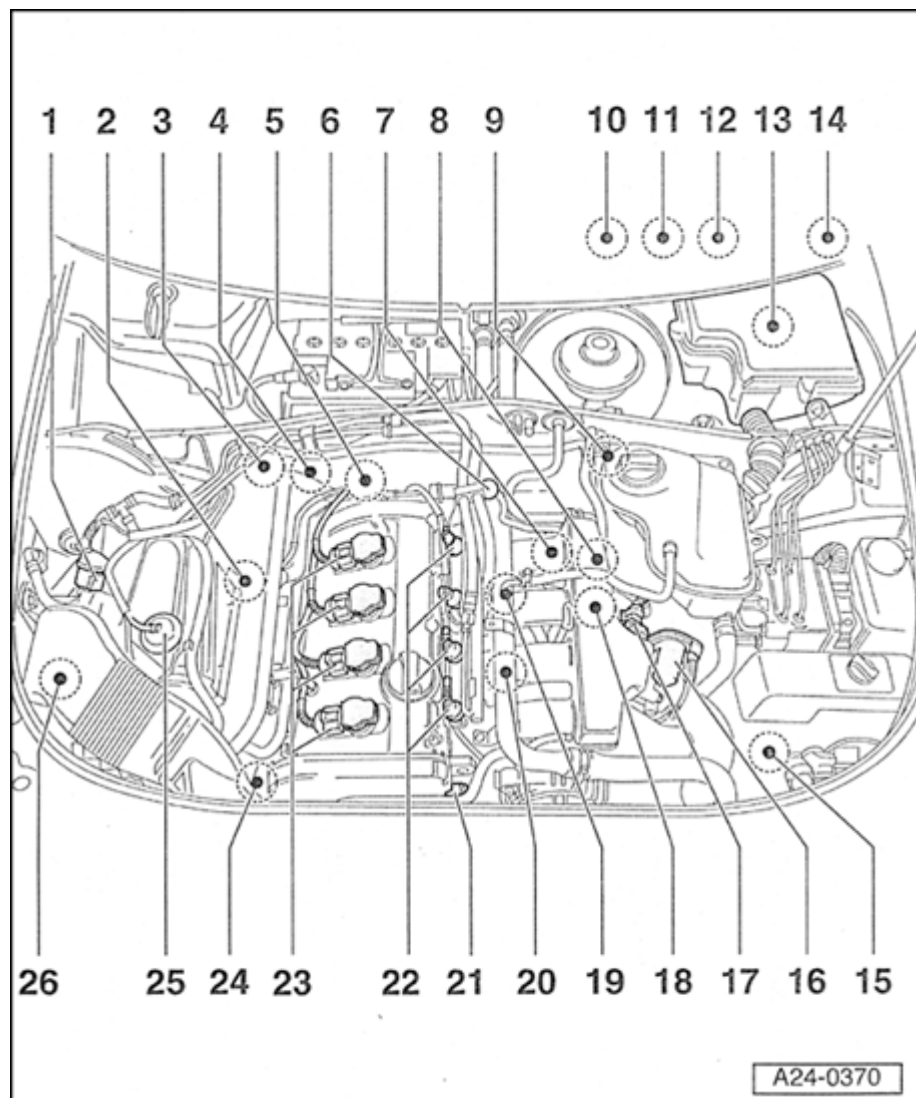

22 - Fuel injectors -N30- through -N33-

- ◆ Checking ⇒ [Page 24-38](#)
- ◆ Removing and installing ⇒ [Page 24-46](#)

23 - Ignition coils -N-, -N128-, -N158-, -N163-

- ◆ Checking ⇒ [Page 28-4](#)

24 - Wastegate bypass regulator valve -N75-

- ◆ Checking:

⇒ [Repair Manual, 1.8 Liter 4-Cyl. 5V Turbo Engine Mechanical, Engine Code\(s\): AEB, ATW, Repair Group 21, Charge air system with turbocharger, checking](#)

25 - Mass Air Flow (MAF) sensor -G70-

- ◆ Checking ⇒ [Page 24-60](#)

26 - Secondary Air Injection (AIR) pump motor-V101-

- ◆ Checking:

⇒ [Repair Manual, 1.8 Liter 4-Cyl. 5V Turbo Engine Mechanical, Engine Code\(s\): AEB, ATW, Repair Group 26; Secondary Air Injection \(AIR\) system, checking](#)

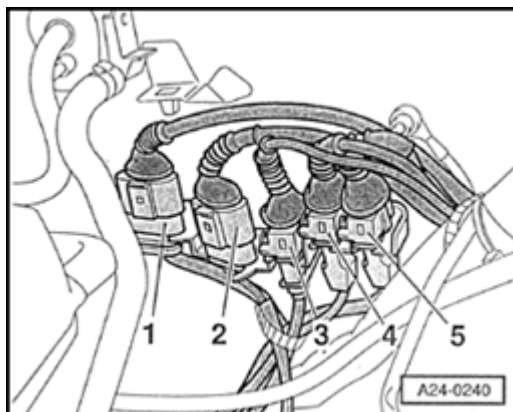

A

Fig. 1 Installation location, harness connectors

The following harness connectors are located below the coolant expansion tank:

1 - 4-pin harness connector, brown

for Oxygen Sensor (O2S) behind Three Way Catalytic Converter (TWC) -G130- and Oxygen Sensor (O2S) Heater 1 -Z29- (bank 1 sensor 2)

2 - 6-pin harness connector, black

for Heated Oxygen Sensor (HO2S) -G39- before catalytic converter and Oxygen Sensor (O2S) Heater -Z19- (bank 1 sensor 1)

3 - 3-pin harness connector, gray

for Engine Speed (RPM) sensor -G28-

4 - 3-pin harness connector, blue

for Knock Sensor (KS) 2 -G66-

5 - 3-pin harness connector, green

for Knock Sensor (KS) 1 -G61-

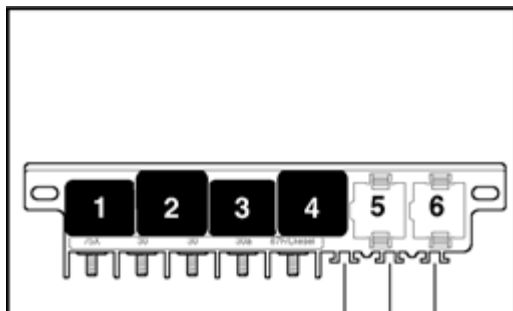

A

Fig. 2 Component locations Fuel Pump (FP) Relay -J17-

Fuel Pump (FP) Relay -J17- is located at position 4 of central electrics in driver's footwell, left.

24-14

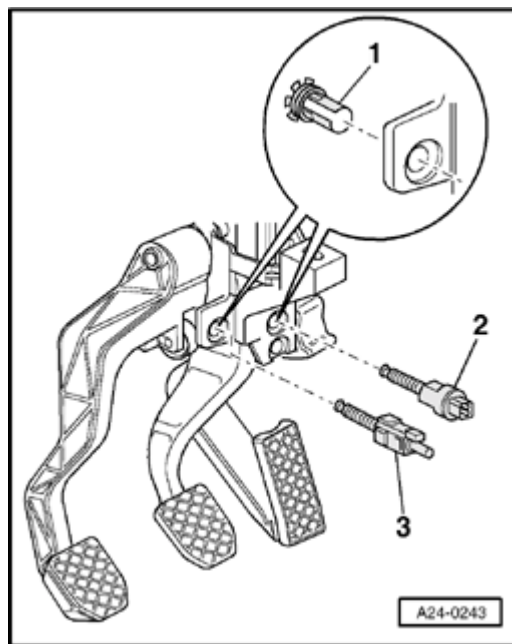

A **Fig. 3** Installation location of brake light switch -F- and brake pedal switch -F47-, clutch vacuum vent valve switch -F36-

- 1 - Clip
- 2 - Clutch vacuum vent valve switch -F36-
- 3 - Brake light switch -F-, brake pedal switch -F47-

Note:

In order to assure sufficiently secure fitting, switches must not be installed more than once.

Adjusting switch:

⇒ [Repair Manual, Brake System, Repair Group 46, Brake booster, removing and installing](#)

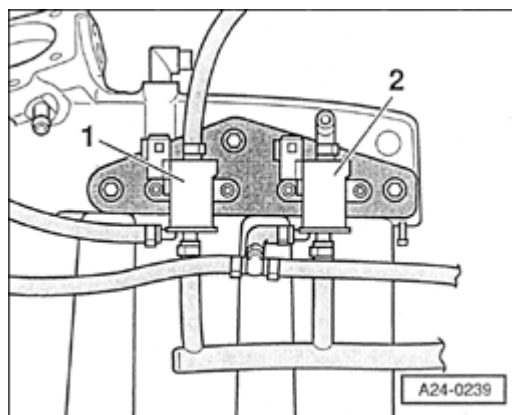

A **Fig. 4** Installation location of Secondary Air Injection (AIR) solenoid valve-N112- and recirculating valve for turbocharger-N249-

- ◆ Installation location: Below intake manifold
- 1 - Recirculating valve for turbocharger -N249-
- 2 - Secondary Air Injection (AIR) solenoid valve -N112-

Note:

Illustration depicts intake manifold removed, from below.

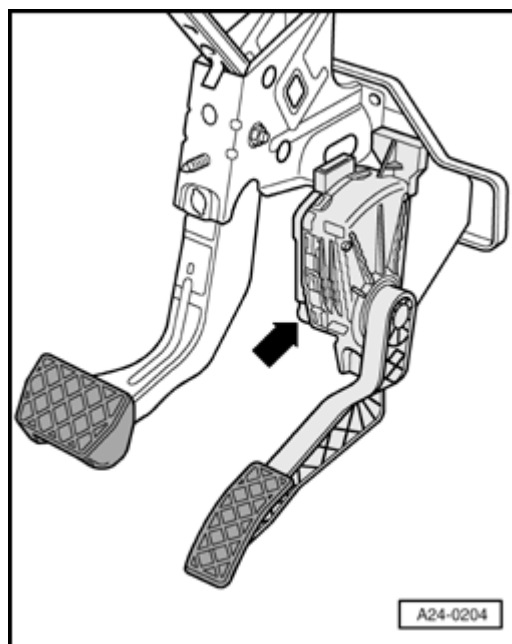

A

Fig. 5 Installation position, Throttle Position (TP) sensor -G79- and sender 2 for accelerator pedal position -G185-

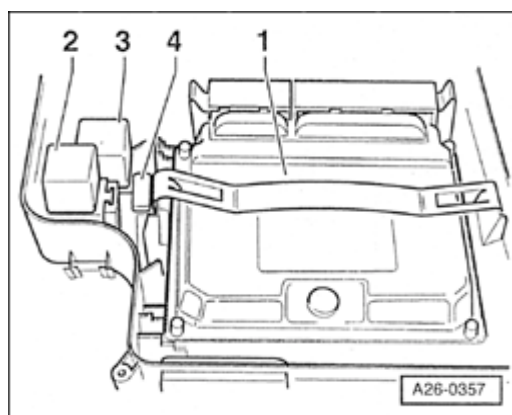

A

Fig. 6 Installation positions in E-box, plenum chamber

- 1 - Engine Control Module (ECM)
- 2 - Secondary Air Injection (AIR) pump relay -J299-
- 3 - Motronic Engine Control Module (ECM) power supply relay -J271-
- 4 - Installation location of fuse S130 for Secondary Air Injection (AIR) pump

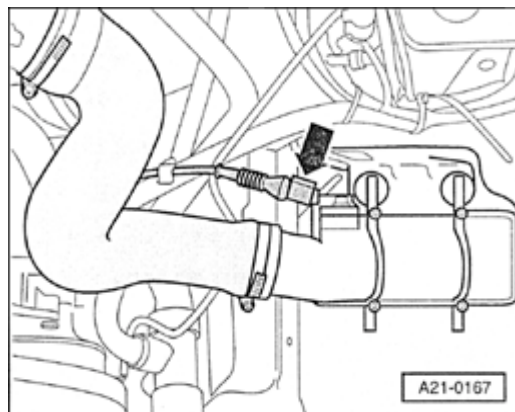

A

Fig. 7 Installation location, charge air pressure sensor -G31-

Charge air pressure sensor -G31- (arrow) bolted into charge air cooler at top

24-17

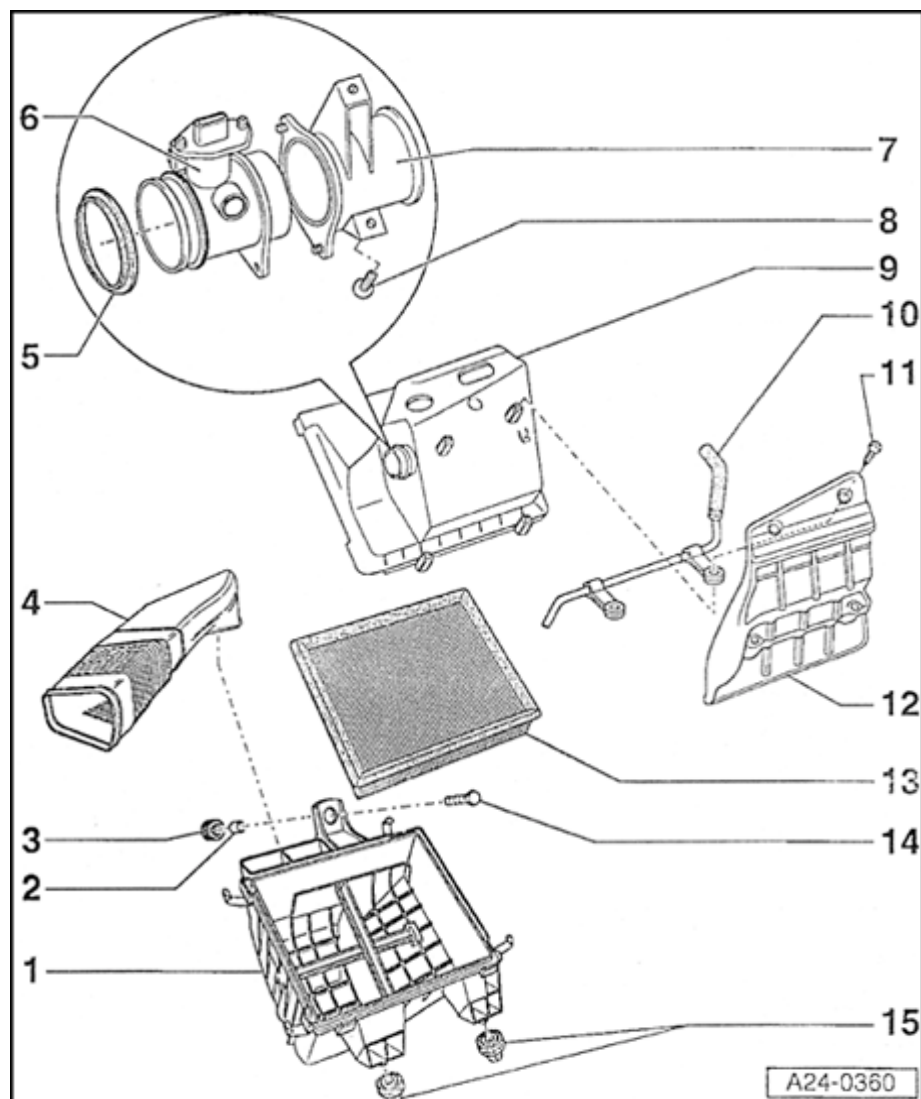

Air cleaner, disassembling and assembling

- 1 - Lower part of air cleaner housing
- 2 - Sleeve
- 3 - Rubber grommet
- 4 - Air duct
 - ◆ to metering unit
- 5 - Seal
- 6 - Mass Air Flow (MAF) sensor -G70-
 - ◆ Checking ⇒ [Page 24-60](#)
- 7 - Air duct
- 8 - 6 Nm
- 9 - Upper part of air cleaner housing

24-18

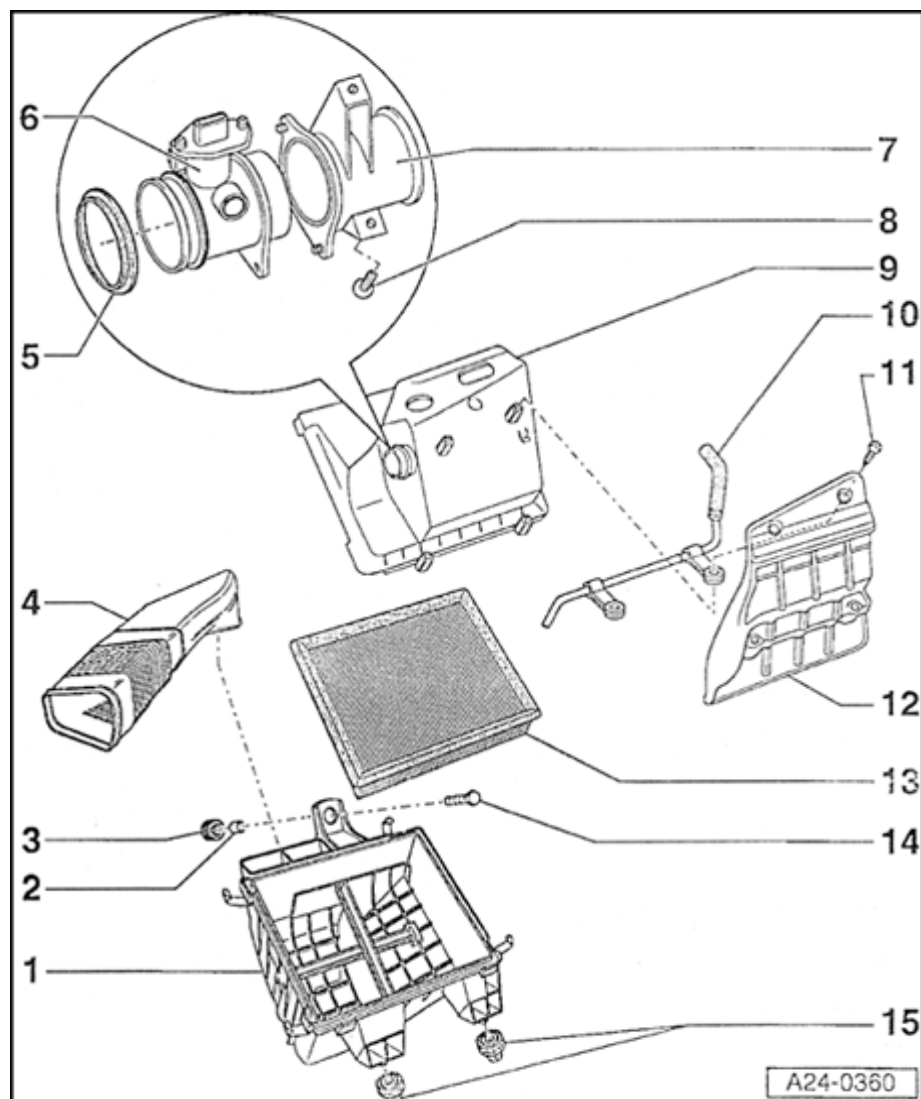
**10 - Wire**

- ◆ For EVAP canister system

11 - 10 Nm**12 - Heat shield****13 - Filter element**

- ◆ Follow filter change intervals

⇒ [Repair Manual, Maintenance](#)

14 - 10 Nm**15 - Rubber grommet**

Wiring and component testing using VAG1598/31 test box

Note:

- ◆ *VAG1598/31 test box is designed so that it can be simultaneously connected to the wiring harness at the Engine Control Module (ECM) and also to the ECM itself.*
- ◆ *This is advantageous because electronic engine control remains fully functional (e.g. measurement of signals with engine running) when the test box is attached.*
- ◆ *Relevant test procedures note whether Engine Control Module (ECM) should also be connected to the test box or not.*
- ◆ *Always use VAG1594A connector test kit to attach measurement devices (e.g. VAG1527B voltage tester, VAG1526 multimeter etc.).*

WARNING!

To avoid damaging electronic components, set measuring range before connecting test leads and observe all test requirements.

Special tools and equipment

A

- ◆ VAG1598/31

Procedure

- Switch ignition off.
- Remove Engine Control Module (ECM) ⇒ [Page 24-23](#) .

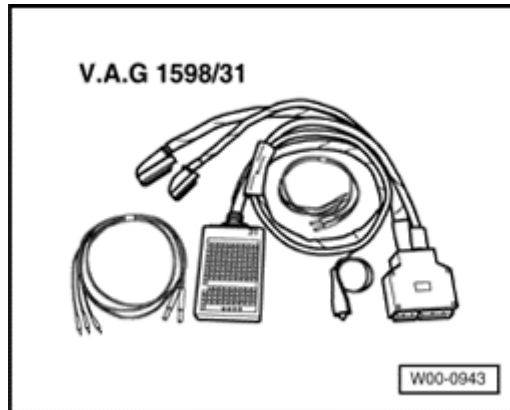

A

- Connect VAG1598/31 test box to connector of wiring harness. Ground (GND) clip at test box (not visible in illustration) must be connected to Ground (GND). Relevant test procedures note whether Engine Control Module (ECM) should also be connected to the test box.
- Perform test as described in relevant repair sequence.

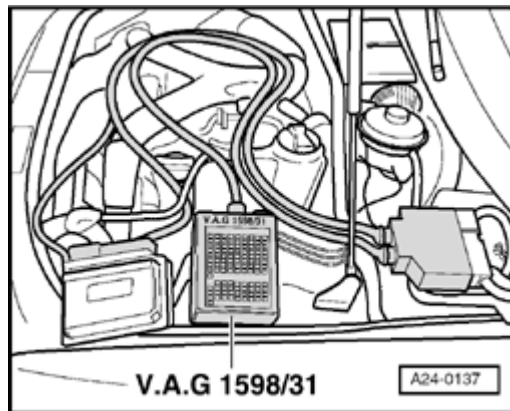

Note:

Important note:

After re-connecting the Engine Control Module (ECM), the following work steps must be performed:

- Perform adaptation of the Throttle Valve Control Module -J338- ⇒ [Page 24-121](#) .

- For vehicles with automatic transmission, the kick down function must be adapted ⇒ [Page 24-139](#) .

- Check DTC memory and erase it if necessary ⇒ [Page 01-16](#) .

- If DTC memory was erased, readiness code must be re-generated ⇒ [Page 01-73](#) .

Note:

During the first adaptation phase, it is possible that idle will be rough and vehicle may shake lightly in drive mode.

Procedure following interruption of voltage supply

Note:

Important note:

After re-connecting voltage supply, the following work steps must be performed:

- Perform adaptation of the Throttle Valve Control Module -J338- ⇒ [Page 24-121](#) .

- For vehicles with automatic transmission, the kick down function must be adapted ⇒ [Page 24-139](#) .

- Check DTC memory and erase it if necessary ⇒ [Page 01-16](#) .

- If DTC memory was erased, readiness code must be re-generated ⇒ [Page 01-73](#) .

Note:

During the first adaptation phase, it is possible that idle will be rough and vehicle may shake lightly in drive mode.

Engine Control Module (ECM), replacing

Special tools and equipment

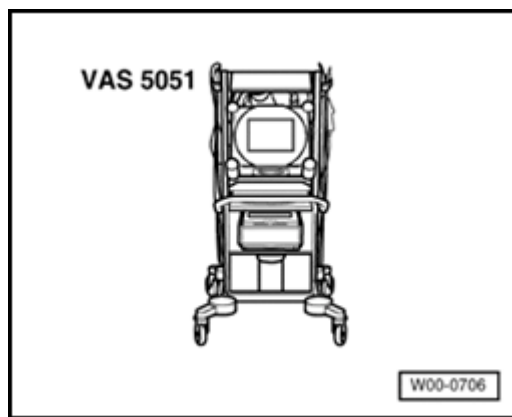

4B0906018Q 1.8 L R4/5VT G 0008 →
Coding 07551 WSC 12345



◆ VAS5051 with VAG5051/1

or

◆ VAG1551 with VAG1551/3A

Removing

- Connect VAS5051 tester or VAG1551 scan tool and select control module for engine electronics using "address word" 01 ⇒ [Page 01-10](#) . Ignition must remain switched on.



VAG1551 Scan Tool (ST) display indicates control module identification, e.g.

- Always allow display of control module identification first and print it out ⇒ [Page 01-13](#) .

- Compare coding with coding versions ⇒ [Page 01-64](#) .

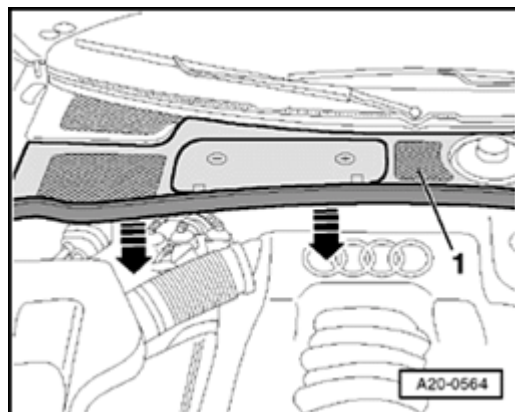

- Switch ignition off.

A

- Pull off rubber seal of plenum chamber cover in direction of arrow.
- Remove cover -1- toward front.

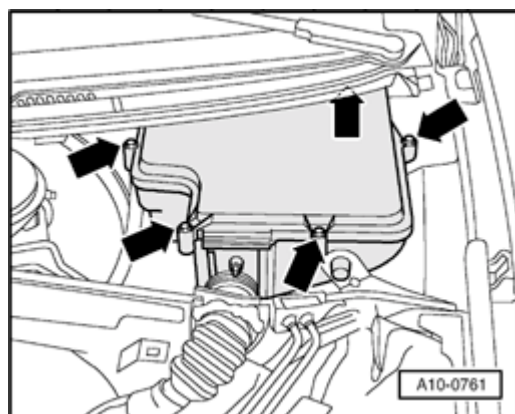

A

- Remove Heater Core E-box cover (arrows).

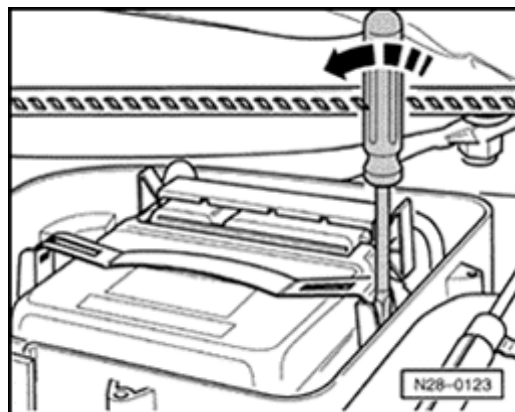

- A**
- Using a screwdriver, carefully pry off retaining bracket (arrow).

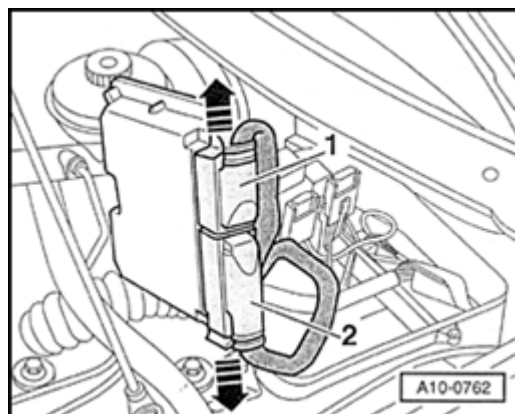

- A**
- Disengage connector catches (arrows) and disconnect harness connectors -1- and -2- from control module.

Note:

Adaptation values are erased when connector is disconnected from the Engine Control Module (ECM), DTC memory content remains intact.

- Remove Engine Control Module (ECM).

Installing

Installation is reverse of removal, noting the following:

Note:

Important note:

After installing new Engine Control Module (ECM), the following work steps must be performed:

- *Check DTC memory and erase it if necessary
⇒ [Page 01-16](#) .*
- *Perform adaptation of the Throttle Valve Control Module -J338- ⇒ [Page 24-121](#) .*
- *Observe notes for coding new Engine Control Module (ECM) ⇒ [Page 01-62](#) .*
- *For vehicles with cruise control (discernable at steering column), switch this free in ECM:

⇒ [Repair Manual, Electrical Equipment On Board Diagnostic \(OBD\), Repair Group 01; OBD for cruise control system](#)*
- *For vehicles with automatic transmission, the kick down function must be adapted ⇒ [Page 24-](#)*

[139](#).

- Adapt immobilizer to Engine Control Module (ECM):

⇒ [Repair Manual, Electrical Equipment On Board Diagnostic \(OBD\), Repair Group 01; OBD of immobilizer - variable code; adaptation after replacing Engine Control Module \(ECM\)](#)

- Generate readiness code ⇒ [Page 01-73](#) .

Note:

During the first adaptation phase, it is possible that idle will be rough and vehicle may shake lightly in drive mode.

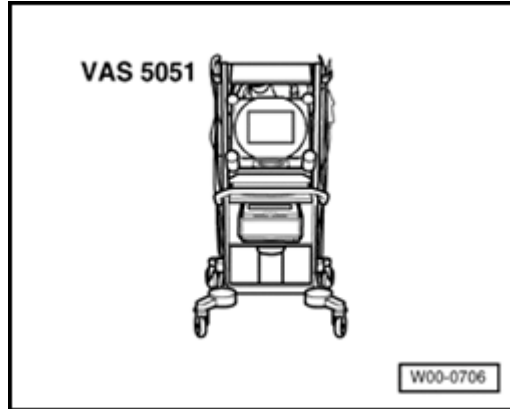

Idle speed (RPM), checking

Special tools and equipment

A

◆ VAS5051 with VAG5051/1

or

◆ VAG1551 with VAG1551/3A

Test requirements:

- Exhaust system free of leaks.
- Coolant Temperature at least 80 ° C.
- Electrical consumers switched off (radiator fan must NOT run during test).
- A/C switched off.
- No pressure gauge connected.
- Vehicles with automatic transmission Selector lever in P or N.

Note:

- ◆ *Idle speed cannot be adjusted.*
- ◆ *Idle speed is checked during basic setting of the engine.*
- ◆ *During basic setting, the Evaporative Emission (EVAP) canister purge regulator valve (EVAP valve -N80-) is closed and the A/C compressor is switched off*

Test sequence

- Check DTC memory ⇒ [Page 01-16](#) . There must not be any DTCs stored, repair malfunctions if necessary, erase DTC memory, switch engine off and start again, road test vehicle and check DTC memory again as a control measure.
- Let engine continue to run at idle.

WARNING!

The electric fan for the radiator must not be running.

Rapid data transfer

HELP

Select function XX



When indicated on display

- Press buttons -0- and -4- to select "Initiate basic setting" and press -Q-

button to confirm input.



A When indicated on display

- Press buttons -0-, -5- and -6- to select "display group number 056" and press -Q- button to confirm input.

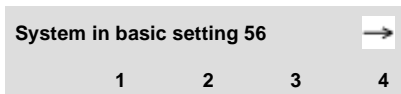

A When indicated on display

- Check whether the engine speed in display field 1 (actual engine speed) is within tolerated range.

	Display fields			
	1	2	3	4
Display group 056: Idle stabilization at operating temperature				
Display	xxx /min	xxx /min	x.x %	X X X X X
Indicated	Engine speed (actual)	Engine speed (specified)	Idle control Torque change	Operating conditions
Specified value	FWD: 740 to 860 RPM AWD: 800 to 920 RPM	FWD: 800 RPM AWD: 860 RPM	x.x %	0 0 0 0 0
Note	If specified value is not obtained ⇒ Page 24-32			Significance of numbers ⇒ Page 24-32

Note:

- ◆ *Engine speed in display field 1 (actual engine speed) is the current engine speed.*
- ◆ *Engine speed in display field 2 (specified engine speed) is a theoretical engine speed calculated by the ECM.*
- ◆ *At idle, the ECM always attempts to adapt the engine speed (actual) to the specified engine speed (specified).*
- ◆ *This means that the engine speed (actual) must always approximately match the engine speed (specified) at idle.*
- ◆ *Display fields 3 and 4 provide information, but are not relevant for checking idle speed.*

If specified value is obtained:

- Press → button.



Indicated on display (function selection):

If specified value is not obtained:

- Check DTC memory again ⇒ [Page 01-16](#) .

Rapid data transfer

HELP

Select function XX

- If DTC memory was erased, readiness code must be re-generated ⇒ [Page 01-73](#) .

If idle speed is too high or low and there are no DTCs in DTC memory, the following tests (marked with dots) must be performed:

- Check for false air in intake air system ⇒ [Page 24-68](#) .
- Check throttle valve control module ⇒ [Page 24-120](#) .
- Evaporative Emission (EVAP) canister purge regulator valve always open, checking ⇒ [Page 24-107](#) .
- Perform adaptation of throttle valve control module ⇒ [Page 24-121](#) .

Significance of 5 digit indication of display group 056

x	x	x	x	x	Display field 4
				0	A/C compressor: 0 = A/C compressor off; 1 = A/C compressor on
			0		Manual transmission: Indication always 0 Driving mode for automatic transmission: 0 = selector lever in P or N; 1 = selector lever in 2/3/4/D/R
		0			Indication always 0
	0				Indication always 0
0					Indication always 0

System pressure, fuel pressure regulator and residual pressure, checking

Note:

Fuel pressure regulator regulates fuel pressure according to intake manifold pressure. This ensures that the pressure drop at the fuel injectors remains the same for each speed and load range of the engine.

Special tools and equipment

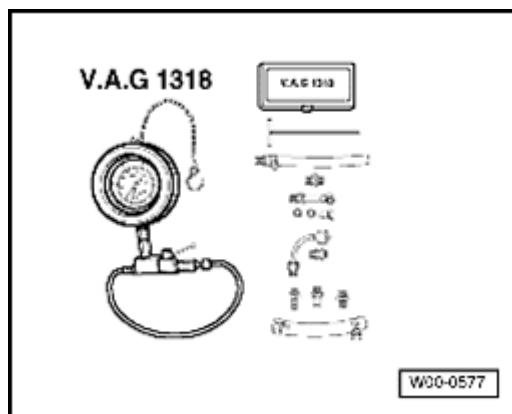

A

- ◆ VAG1318
- ◆ V.A.G 1318 with V.A.G 1318/11 adapter, V.A.G 1318/12 pressure hose with connectors and V.A.G 1318/13 adapter

Test requirements:

- Fuel Pump (FP) relay OK; checking ⇒ [Page 24-53](#) .
- Fuel Pump (FP) OK, checking:

⇒ [Repair Manual, Fuel Supply System, Repair Group 20](#)

- Fuel filter OK
- Battery voltage at least 12.7 V
- Vehicles with automatic transmission Selector lever in P or N.

Checking system pressure

- Open fuel filler flap briefly (pressure release).

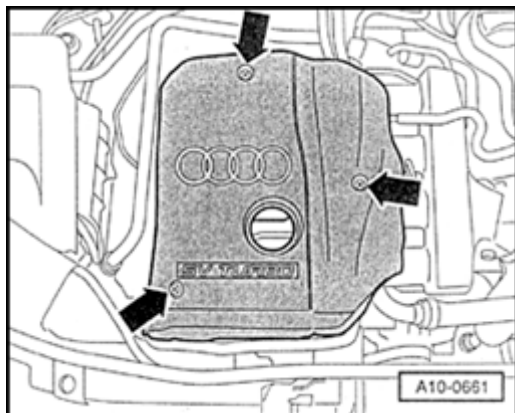

A - Remove engine cover (arrows).

WARNING!

Fuel system is under pressure! Before opening system, place rags around the connection point. Then release pressure by carefully loosening connection.

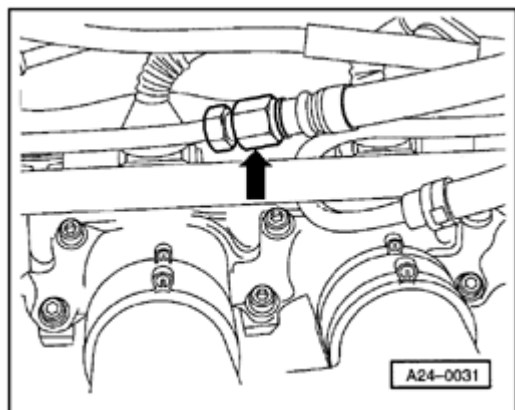

A - Open threaded connection (arrow) and catch exiting fuel using a rag.
- Connect VAG1318 pressure gauge in supply line using adapters 1318/11, 1318/12 and 1318/13.

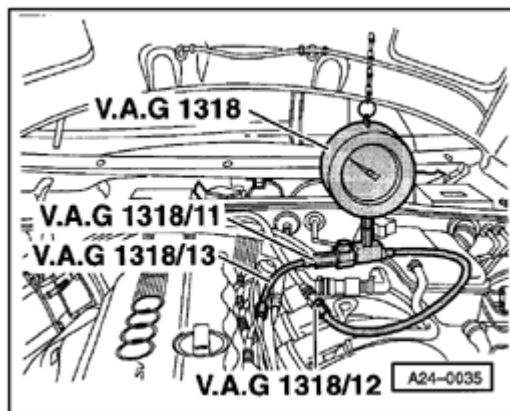

- A
- Open shut-off valve of pressure gauge. The lever points in the direction of flow.
 - Start engine and let run at idle.
 - Measure fuel pressure.
 - ◆ Specification: about 3.5 bar positive pressure

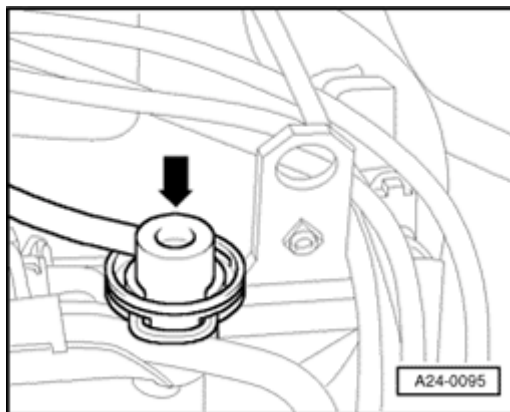

- A
- Disconnect vacuum hose at fuel pressure regulator.
 - ◆ Fuel pressure must rise to about 4.0 bar positive pressure.
 - Switch ignition off.
 - Check for proper seal and residual pressure by observing pressure drop on pressure gauge.
 - ◆ After 10 minutes, there must be at least 2.5 bar positive pressure

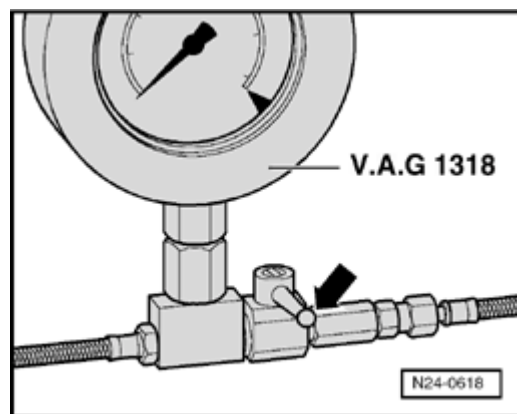

If residual pressure sinks below 2.5 bar positive pressure:

- Start engine and let run at idle.
- Wait until pressure has dropped, and then switch off ignition. Simultaneously close shut-off valve of VAG1318 pressure gauge (lever perpendicular to direction of flow -arrow-).
- Observe pressure drop on pressure gauge.

If pressure does not drop now:

- Test check-valve on Fuel Pump (FP).

If pressure drops again:

- Open shut-off valve of pressure gauge. The lever points in the direction of flow.
- Start engine and let run at idle.
- Wait until pressure has dropped, and then switch off ignition. Simultaneously clamp return line (with blue marking) completely closed.

If pressure does not drop now:

- Replace fuel pressure regulator

If pressure drops again:

- Check wire connections, O-rings at fuel distributor and fuel injectors for proper seal.
- Check whether pressure gauge is properly sealed.

Note:

Before disconnecting pressure gauge, release pressure by opening shut-off valve. Hold a container in front of connection for this.

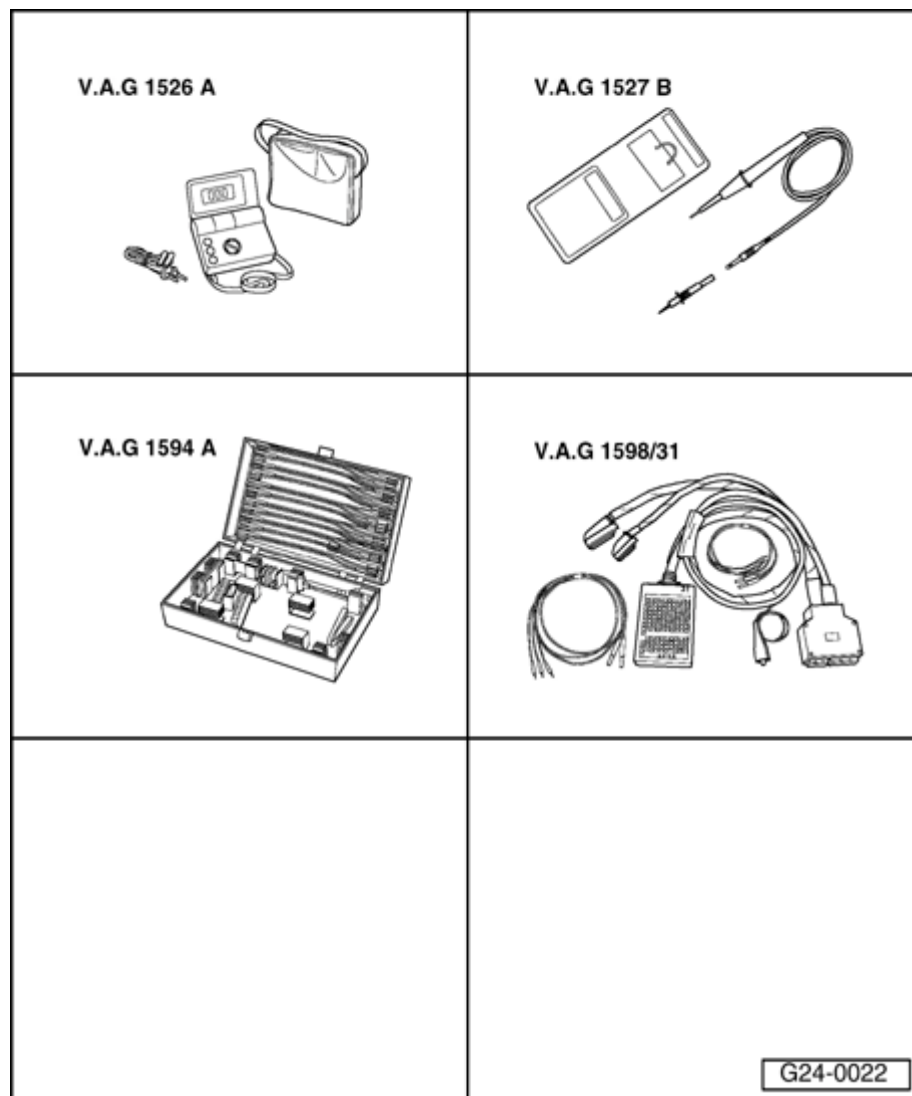

Fuel injectors, checking

Special tools and equipment

- ◆ VAG1526A
- ◆ VAG1527B
- ◆ VAG1594A
- ◆ VAG1598/31

Checking internal resistance

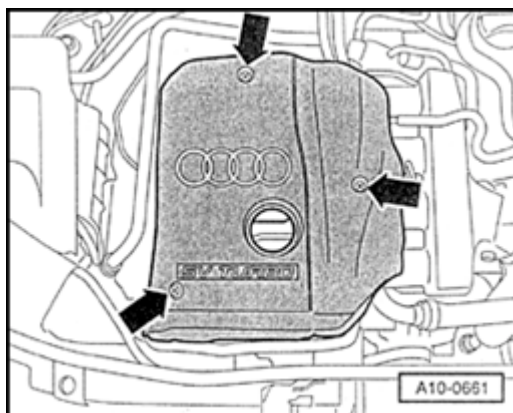

- ▲ - Remove engine cover (arrows).
- Disconnect harness connector at the fuel injector to be tested.

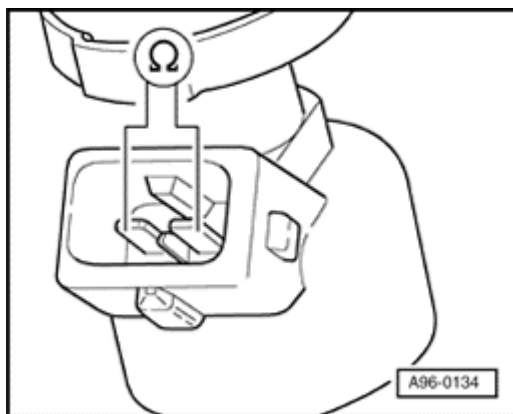

- ▲ - Connect multimeter at valve for resistance measurement.
 - ◆ Specification: 12 to 13 Ω (at room temperature)

If specified value is not obtained:

- Replace fuel injector.

If specified value is obtained:

- Check voltage supply

Checking voltage supply

Test requirements:

- Fuse for fuel injectors OK

⇒ *Electrical Wiring Diagrams, Troubleshooting & Component Locations*

- Fuel Pump (FP) relay OK; checking ⇒ [Page 24-53](#).

- Disconnect harness connector at the fuel injector to be tested.

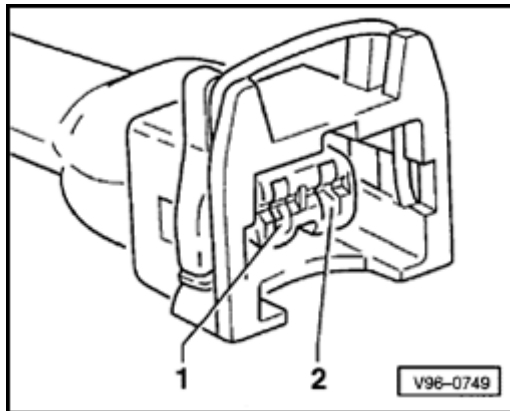

A

- Connect VAG1527B voltage tester as follows:

Harness connector	Measure to
Terminal	
1	Engine Ground (GND)

- Switch ignition on.
 ◆ LED must light up.

If LED does not light up:

- Check wire connection between terminal 1 and fuse for injector valves for open circuit:

⇒ *Electrical Wiring Diagrams, Troubleshooting & Component Locations*

- Repair open circuit if necessary.

If LED lights up:

- Activation of fuel injectors, checking

Checking activation

Test requirement:

- Internal resistance of valve OK
- Slide back rubber grommet of fuel injector connector, but leave connector connected.

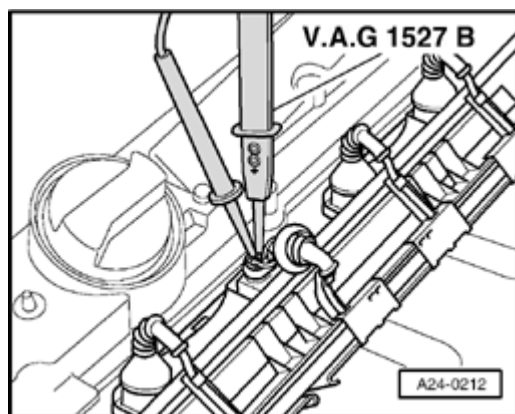

A

- Connect VAG1527B voltage tester between sockets 2 (signal) and 1 (B+).
- Operate starter briefly (engine can also start).
 - ◆ LED must blink.

Note:

Voltage testers do not go out completely during low current pick-up between activations by the ECM, but rather continue to glow a little and then get slightly brighter during activation.

If LED does not blink:

- Connect VAG1598/31 test box at wiring harness to Engine Control Module (ECM), do not connect ECM ⇒ [Page 24-19](#) .

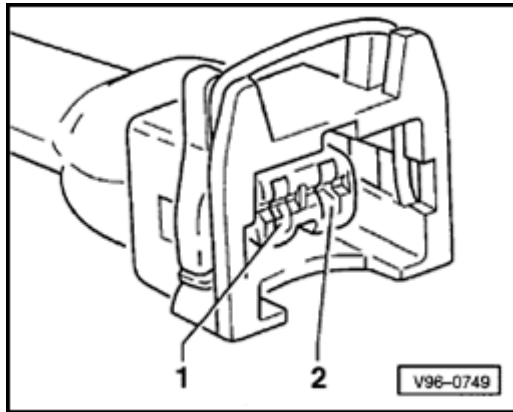

A

- Check following wire connections for open circuit and short circuit to Ground (GND) and B+:

Cylinder	Fuel injector harness connector	VAG1598/31 test box
	Terminal	Socket
1	2	96
2	2	89
3	2	97
4	2	88

- Repair open circuit or short circuit if necessary.

If wire connection is OK:

- Replace Engine Control Module (ECM) ⇒ [Page 24-23](#)

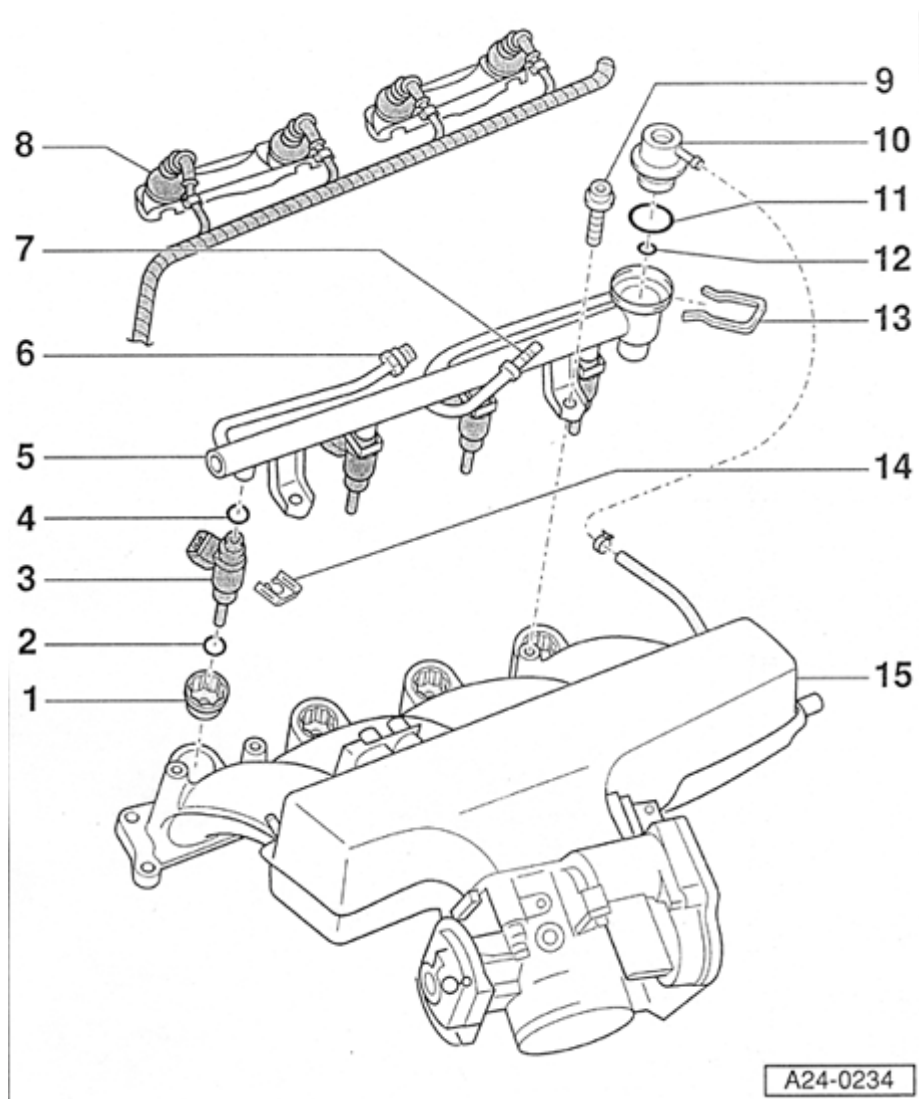

Fuel rail with fuel injectors, disassembling and assembling

1 - Fuel injector insert, 3 Nm

- ◆ Use fluid securing material D 000 600 A2 to insert.

2 - O-ring

- ◆ Removing and installing ⇒ [Page 24-46](#)
- ◆ Always replace
- ◆ Coat with clean engine oil

3 - Fuel injectors -N30- through -N33-

- ◆ Removing and installing ⇒ [Page 24-46](#)

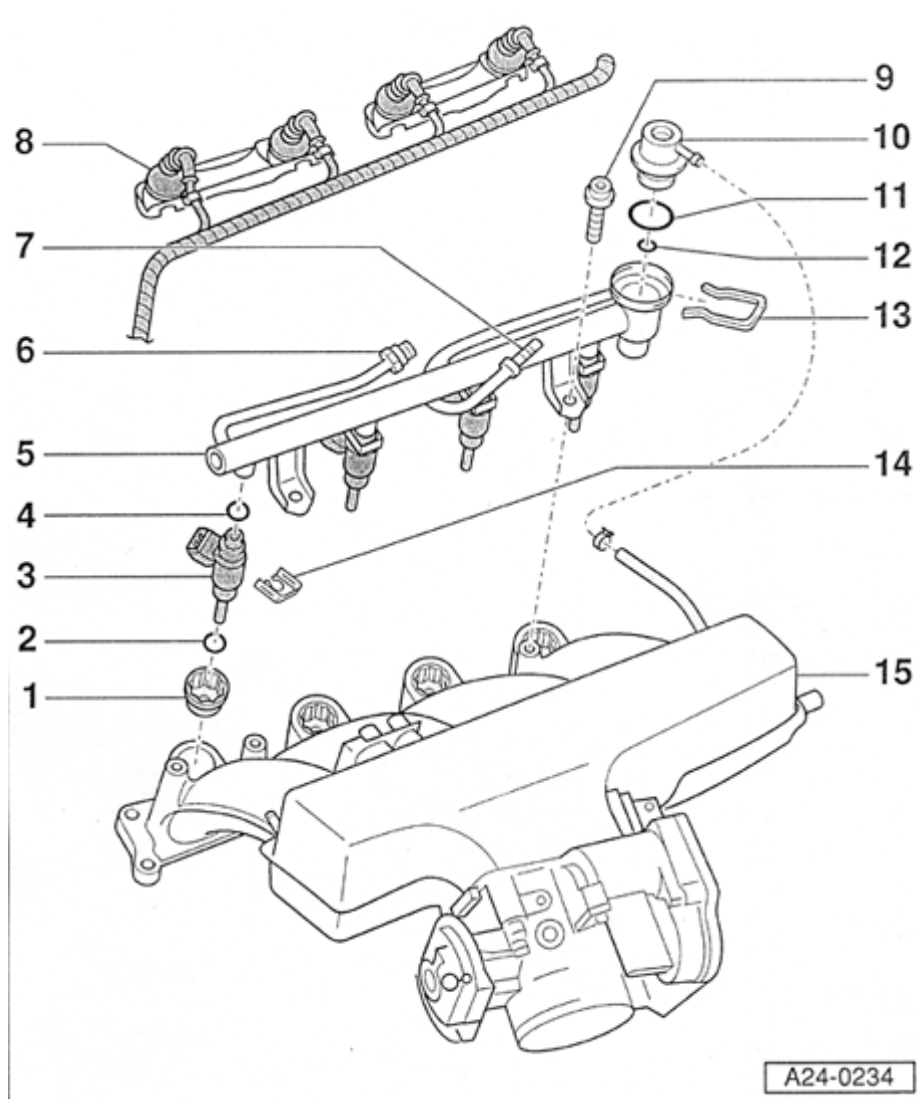
**4 - O-ring**

- ◆ Removing and installing ⇒ [Page 24-46](#)
- ◆ Always replace
- ◆ Coat with clean engine oil

5 - Fuel distributor**6 - Fuel supply line**

- ◆ Tighten to 25 Nm

7 - Fuel return line**8 - Harness connector**

- ◆ for injectors
- ◆ 4x

9 - Socket head bolt- 10 Nm**10 - Fuel pressure regulator**

Fuel injectors, removing and installing

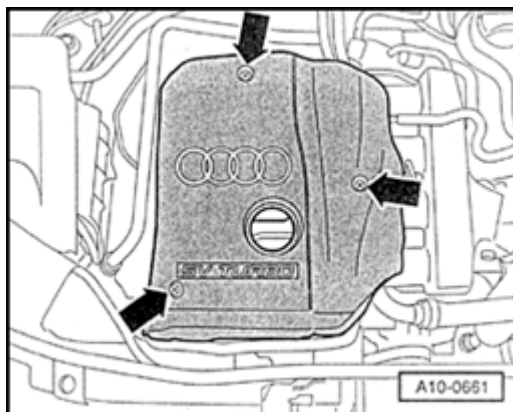
**A**

- Remove engine cover (arrows).
- Disconnect wiring/connectors at:
 - Fuel injectors -N30-, -N31-, -N32-, -N33-
 - Intake Air Temperature (IAT) sensor -G42-
 - Camshaft Position (CMP) sensor 2 -G40-
 - Throttle valve control module -J338-

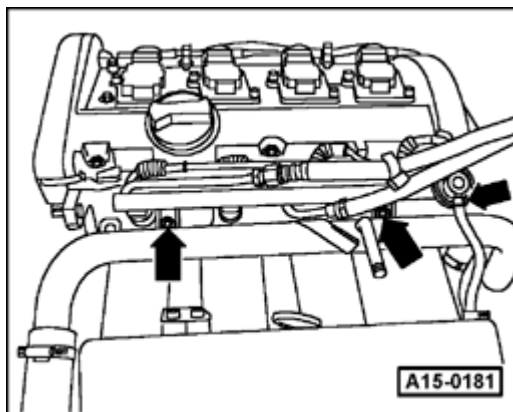
**A**

- Remove retaining bolts for fuel supply rail and disconnect vacuum line at fuel pressure regulator (arrows).

- Disconnect fuel distributor with injectors from intake plenum and set aside in rear of engine compartment on a clean cloth.

WARNING!

Fuel system is under pressure! Before opening system, place rags around the connection point. Then release pressure by carefully loosening connection.

- Disengage retaining clip and remove fuel injector.

Note:

Fuel lines must be removed before replacing fuel distributor.

Installation is reverse of removal, noting the following:

- Remove O-rings at all opened connections. (Never remove plastic cap from valve head to replace front O-ring - pry O-ring off over plastic cap).
- Lightly lubricate O-rings with clean engine oil.

- Make sure fuel injectors are in place and seated correctly
- Check clip for unobstructed fitting.
- Place fuel rail with secured fuel injectors onto intake manifold, and apply uniform pressure to press it in.

Tightening torque

Component	Nm
Fuel distributor at intake manifold	10

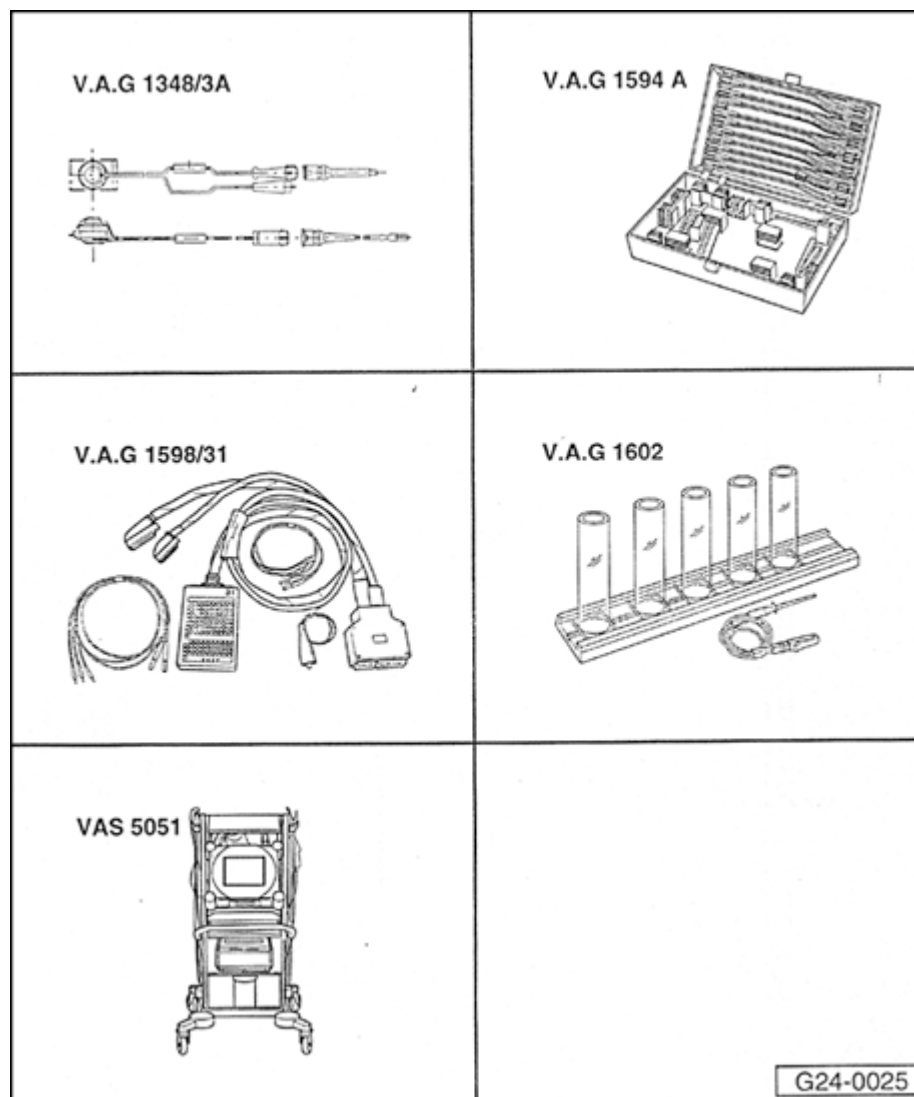

Fuel injector injection quantity, proper seal and spray pattern, checking

Special tools and equipment

- ◆ VAG1348/3A
- ◆ VAG1594A
- ◆ VAG1598/31
- ◆ VAG1602
- ◆ VAS5051 with VAG5051/1
- or
- ◆ VAG1551 with VAG1551/3A

Test requirement:

- Fuel pressure OK, checking ⇒ [Page 24-33](#) .

Test sequence

- Remove fuel distributor including fuel injectors from intake manifold ⇒ [Page 24-46](#) . Fuel lines remain connected.
- Connect VAG1598/31 test box at wiring harness to Engine Control Module (ECM), do not connect ECM ⇒ [Page 24-19](#) .

Checking Proper Seal

- Bridge terminals 1 and 65 at test box using wires from VAG1594A adapter test kit.
- Switch ignition on.
 - ◆ Fuel Pump (FP) must run.
- Check proper seal of fuel injectors (visual inspection). With Fuel Pump (FP) running, only 1 to 2 drops per minute may drip out per injector.
- If fuel loss is greater, stop Fuel Pump (FP) from

running (switch off ignition) and replace faulty fuel injector ⇒ [Page 24-46](#) .

Checking Injection Quantity

- Insert fuel injector to be tested in a measuring glass from VAG1602 injection quantity test device.

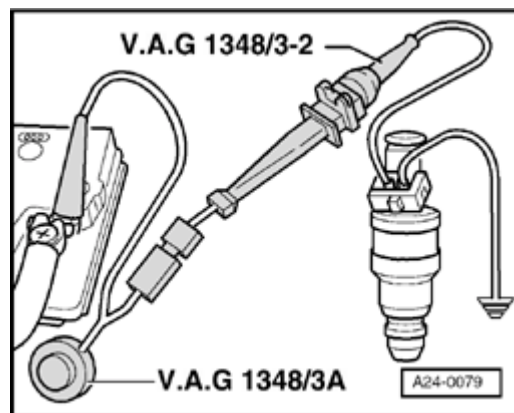

▲

- Connect one terminal of fuel injector to engine Ground (GND) using an adapter cable and an alligator clip from VAG1594A connector test kit.
- Connect second terminal of fuel injector to B+ using VAG1348/3A remote control, VAG1348/3-2 adapter cable and assisting cable.
- Bridge terminals 1 and 65 at test box using wires from VAG1594A adapter test kit.
- Bridge terminals 1 and 65 at test box using wires from VAG1594A adapter test kit.
- Switch ignition on.
 - ◆ Fuel Pump (FP) must run.
- Activate VAG1348/3A remote control for 30 seconds.
- Perform measurement on all fuel injectors.

- After all four fuel injectors have been activated, place measuring glasses on an even surface.
 - ◆ Specified value for each fuel injector: 135 ± 10 ml
- If measured value of one or more fuel injectors is outside of specified range, switch Fuel Pump (FP) off (switch ignition off) and replace faulty fuel injector ⇒ [Page 24-46](#) .
- If measured values of all fuel injectors are outside specified range, check fuel pressure ⇒ [Page 24-33](#) .

Note:

Also check spray pattern when checking injection quantity. Spray pattern must be the same for all injectors

- Install fuel injectors together with fuel distributor ⇒ [Page 24-47](#) .

24-53

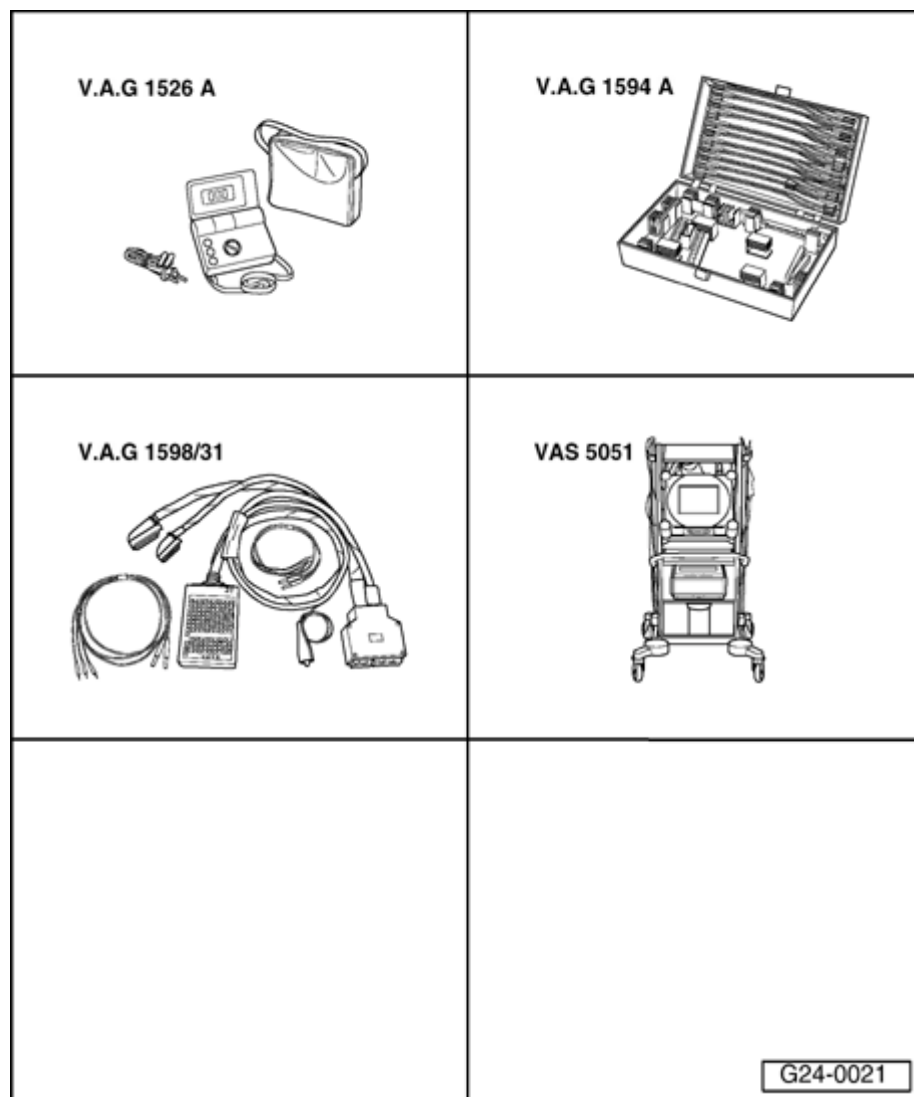

Fuel Pump (FP) relay -J17- and activation, checking

Special tools and equipment

- ◆ VAG1526A
- ◆ VAG1594A
- ◆ VAG1598/31
- ◆ VAS5051 with VAG5051/1
- or
- ◆ VAG1551 with VAG1551/3A

Component location ⇒ Overview of component locations ⇒ [Page 24-5](#) .

Voltage is supplied to the Fuel Pump (FP) and several components of the injection system via the Fuel Pump (FP) relay -J17-.

Engine must be turning for Fuel Pump (FP) relay -J17- to close. This means that the relay does not receive Ground (GND) (via ECM) until the ECM recognizes RPM signals.

Test requirement:

- Battery voltage at least 12.7 V

Function test of Fuel Pump (FP) relay

- Remove driver-side storage compartment.

⇒ [Repair Manual, Body Interior, Repair Group 68](#)

- Connect VAS5051 tester or VAG1551 scan tool and select control module for engine electronics using "address word" 01 ⇒ [Page 01-10](#) . Ignition must remain switched on.
- Initiate output Diagnostic Test Mode (DTM) ⇒

[Page 01-49](#) and activate Evaporative Emission (EVAP) canister purge regulator valve -N80-.

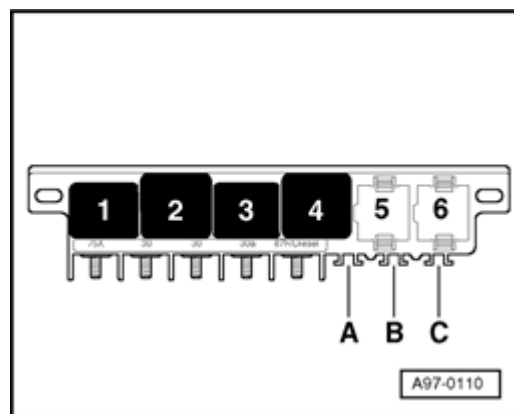

A

- ◆ Fuel Pump (FP) relay (at position 4 of central electrics in driver's footwell, left) must trigger and Fuel Pump (FP) must run.

A - If relay does not trigger:

- Check voltage supply of Fuel Pump (FP) relay ⇒ [Page 24-55](#) .
- Checking activation of Fuel Pump (FP) relay ⇒ [Page 24-56](#) .

B - If relay triggers, but Fuel Pump (FP) does not run:

- Check voltage supply for Fuel Pump (FP) and components (via Fuel Pump -FP- relay) ⇒ [Page 24-58](#) .

Check voltage supply of Fuel Pump (FP) relay

- Remove Fuel Pump (FP) relay.

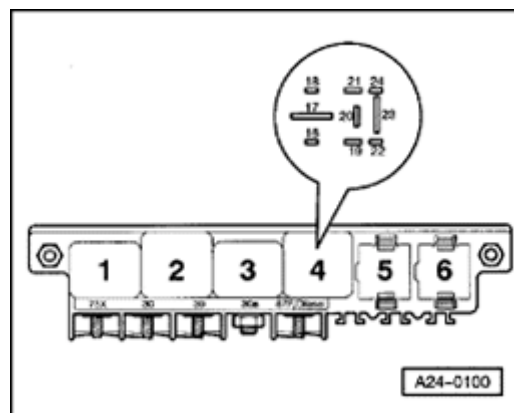

A

- Connect multimeter to terminal 17 of relay socket and Ground (GND) for voltage measurement.

- ◆ Specification: approx. battery voltage

If specified value is not obtained:

- Replace central electrics.

Checking activation of Fuel Pump (FP) relay

- Switch ignition off.
- Connect VAG1598/31 test box at wiring harness to Engine Control Module (ECM), do not connect ECM ⇒ [Page 24-19](#) .
- Switch ignition on.
- Bridge terminals 1 and 65 at test box using wires from VAG1594A adapter test kit.

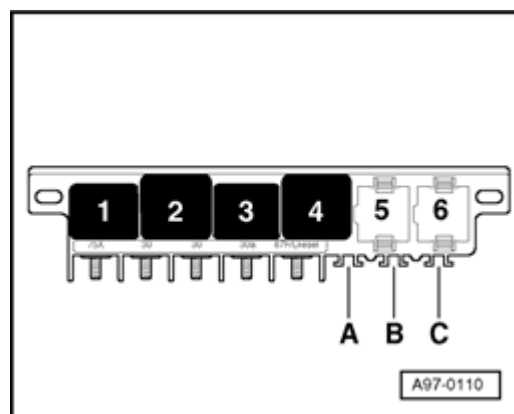

A

- ◆ Fuel Pump (FP) relay (at position 4 of central electrics in driver's footwell, left) must trigger.

If relay triggers now, but didn't during output DTM:

- Replace Engine Control Module (ECM) ⇒ [Page 24-23](#)

If relay does not trigger:

- Switch ignition off.
- Remove cable bridge.

- Remove Fuel Pump (FP) relay.

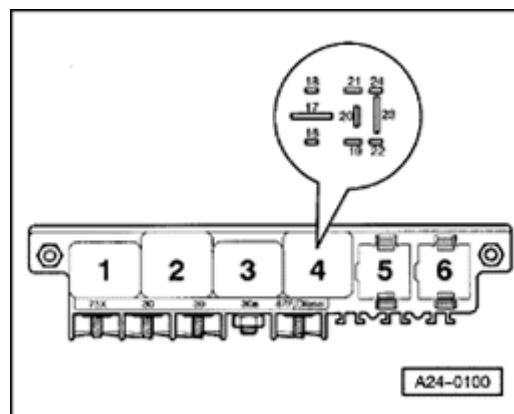

A

- Connect multimeter for voltage measurement as follows.

Central electronics in driver-side footwell, left, position 4	Measure to
Terminal	
19	Engine Ground (GND)

- Switch ignition on.

◆ Specification: approx. battery voltage

If specified value is not obtained:

- Check wire connections.

⇒ *Electrical Wiring Diagrams, Troubleshooting & Component Locations*

If specified value is obtained:

- Check following wire connection for open circuit and short circuit to Ground (GND) and B+:

Central electronics in driver-side footwell, left, position 4	VAG1598/31 test box
Terminal	
	Socket

16	65
----	----

- Repair open circuit or short circuit if necessary.

If no malfunctions are detected:

- Replace Fuel Pump (FP) relay -J17-.
- Re-connect Engine Control Module (ECM).

Check voltage supply for Fuel Pump (FP) and components

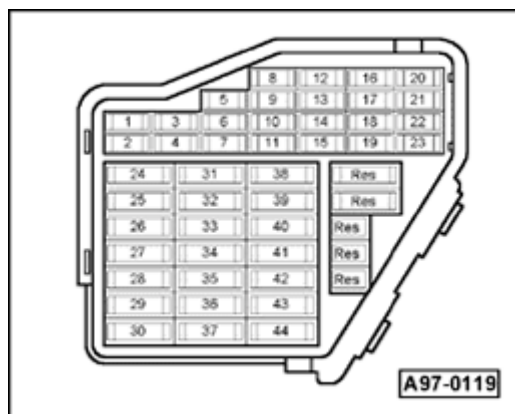

A

- Remove fuses S228, S232, and S234 (positions 28, 32, and 34) from fuse holder.
- Initiate output Diagnostic Test Mode (DTM) ⇒ [Page 01-49](#) and activate Evaporative Emission (EVAP) canister purge regulator valve -N80-.
- Connect multimeter for voltage measurement to Ground (GND) and to one terminal of following fuses in fuse holder.

Circlip	Specified value at one of the terminals
S228	approx. battery voltage
S232	approx. battery voltage
S234	approx. battery voltage

If specified values are not obtained:

- Repeat test at another terminal of fuse socket.

If specified values are not obtained again:

- Check wire connections.

⇒ *Electrical Wiring Diagrams, Troubleshooting & Component Locations*

If no malfunctions are detected:

- Replace Fuel Pump (FP) relay -J17-.
- Re-insert fuses.

24-60

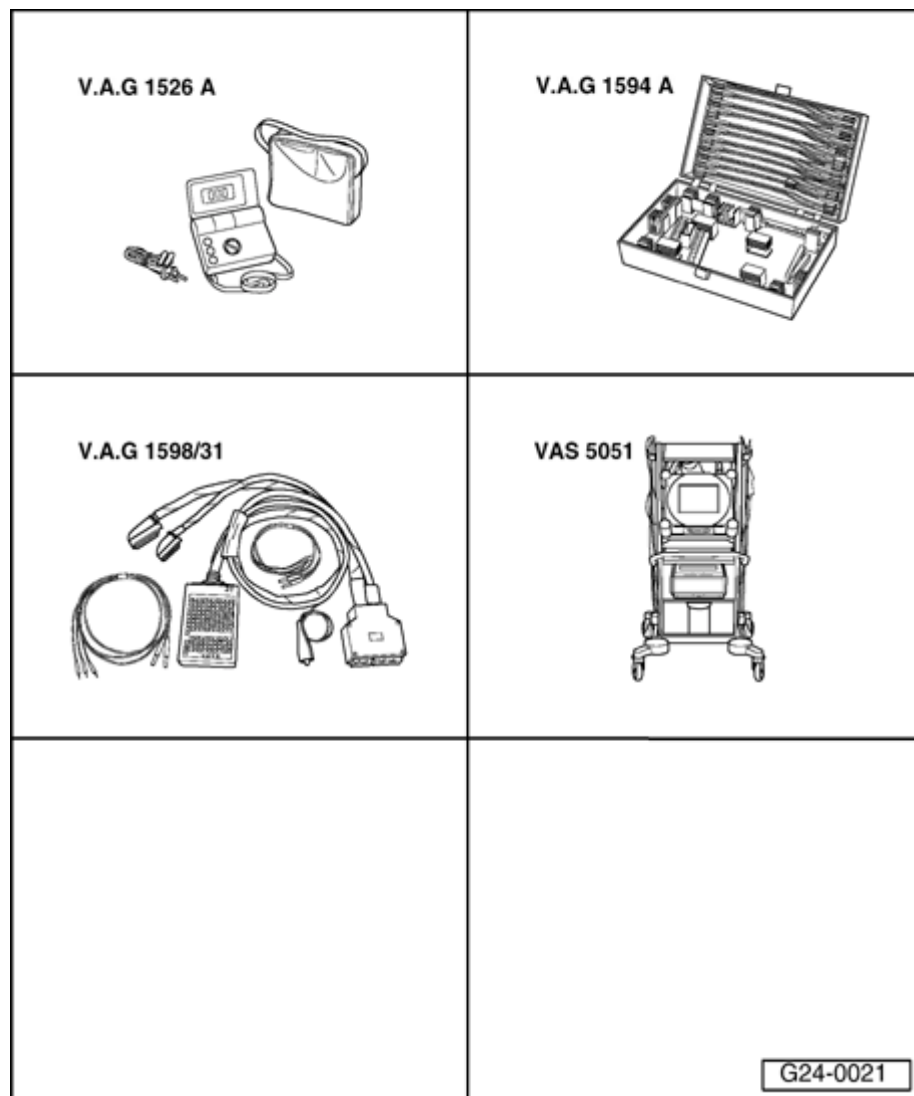

Mass Air Flow (MAF) sensor -G70-, checking

Special tools and equipment

- ◆ VAG1526A
- ◆ VAG1594A
- ◆ VAG1598/31
- ◆ VAS5051 with VAG5051/1
- or
- ◆ VAG1551 with VAG1551/3A

Component location ⇒ Overview of component locations ⇒ [Page 24-5](#)

Test requirements:

- Coolant Temperature at least 80 ° C.
- Electrical consumers switched off (radiator fan must NOT run during test).
- A/C switched off.

Checking function

- Connect VAS5051 tester or VAG1551 scan tool and select control module for engine electronics using "address word" 01 ⇒ [Page 01-10](#) . Engine must run at idle.

Rapid data transfer HELP
Select function XX



When indicated on display

- Press buttons -0- and -4- to select "Initiate basic setting" and press -Q- button to confirm input.

Basic Setting Q
Enter display group number XXX



When indicated on display

- Press buttons -0-, -0- and -2- to select "display group number 002" and press -Q- button to confirm input.

When indicated on display

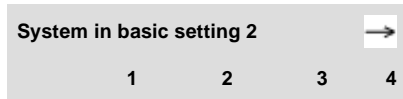

↳ - Check specified values for load detection.

	Display fields			
	1	2	3	4
Display group 002: Air mass taken in with engine at idle and operating temperature				
Display	xxx /min	xxx %	xx.x ms	xxx.x g/s
Indicated	Engine speed (RPM)	Load	mean injection time	Air mass
Specified value	FWD: 740 to 860 RPM AWD: 800 to 920 RPM	15 to 33 %	1.0 to 4.0 ms	2.0 to 4.5 g/s
Note	---	---	If specified value is not obtained: Evaluation ⇒ Page 24-63	

If specified value is obtained:

- Press → button.



Indicated on display (function selection):

Rapid data transfer

HELP

Select function XX

Evaluation display group 002

Display field: 3	Possible cause	Corrective action
less than 1.0 ms	◆ Smaller values are only possible when driving in deceleration mode	
larger than 4.0 ms	◆ Engine under load due to power accessories.	- Reduce load (A/C system/power steering/generator)
	◆ Poor idle (does not run on all cylinders)	- Check spark plugs. - Check fuel injectors ⇒ Page 24-38 .
	◆ Throttle valve control module - J338- faulty	- Check throttle valve control module ⇒ Page 24-120
Display field: 4	Possible cause	Corrective action
smaller than 2.0 g/s	◆ large false air mass between intake manifold and Mass Air Flow (MAF) sensor	- Check intake system for leaks (false air) ⇒ Page 24-68 .
	◆ Voltage supply of Mass Air Flow (MAF) sensor or wire connections to Engine Control Module (ECM)	- Check voltage supply and wire connections ⇒ Page 24-64
larger than 4.5 g/s	◆ Engine under load due to power accessories.	- Reduce load (A/C system/power steering/generator)
	◆ Voltage supply of Mass Air Flow (MAF) sensor or wire connections to Engine Control Module (ECM)	- Check voltage supply and wire connections ⇒ Page 24-64

Voltage supply for Mass Air Flow (MAF) sensor, checking

Test requirements:

- Fuse for Mass Air Flow (MAF) sensor OK

⇒ *Electrical Wiring Diagrams, Troubleshooting & Component Locations*

- Fuel Pump (FP) relay OK; checking ⇒ [Page 24-53](#) .

Note:

Voltage is supplied to Mass Air Flow (MAF) sensor from Fuel Pump (FP) relay.

- Disconnect connector from Mass Air Flow (MAF) sensor.

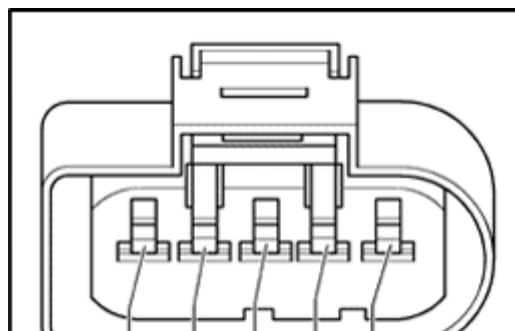

A

- Connect multimeter for voltage measurement as follows.

Harness connector	Measure to
Terminal	
2	Engine Ground (GND)

- Operate starter briefly (engine can also start).
 - ◆ Specification: approx. battery voltage

If specified value is not obtained:

- Check wire connection from terminal 2 of connector to Fuel Pump (FP) relay via fuse for open circuit and short circuit to Ground (GND):

⇒ *Electrical Wiring Diagrams, Troubleshooting & Component Locations*

- Repair open circuit or short circuit if necessary.

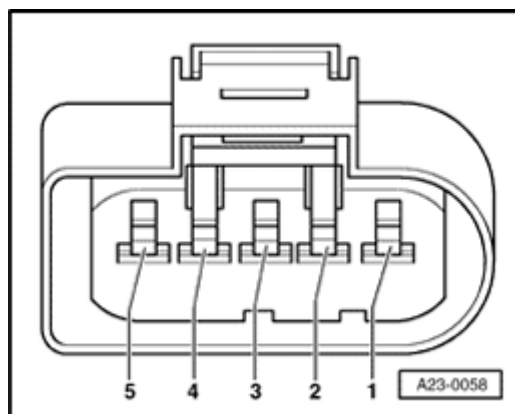

A

- Connect multimeter to terminal 2 and terminal 3 of connector for voltage measurement.
- Operate starter briefly (engine can also start).
 - ◆ Specification: approx. battery voltage

Note:

Ground (GND) from the ECM is present at terminal 3 of connector.

If specified value is not obtained:

- Check wire connections ⇒ [Page 24-67](#) .

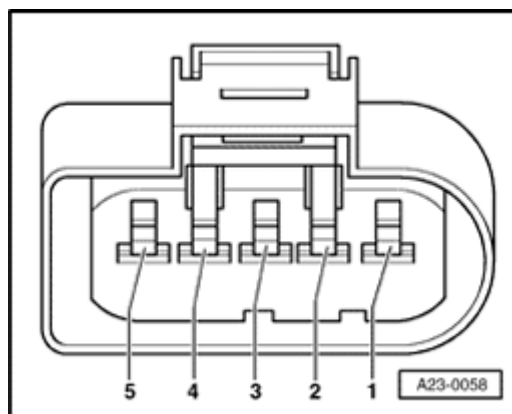

- Connect multimeter to terminal 3 and terminal 4 of connector for voltage measurement.

◆ Specification: about 5 V

If specified value is not obtained:

- Check wire connections ⇒ [Page 24-67](#) .

Check wire connections for Mass Air Flow (MAF) sensor

Note:

Signal wire is also checked during wire test.

- Connect VAG1598/31 test box at wiring harness to Engine Control Module (ECM), do not connect ECM ⇒ [Page 24-19](#) .

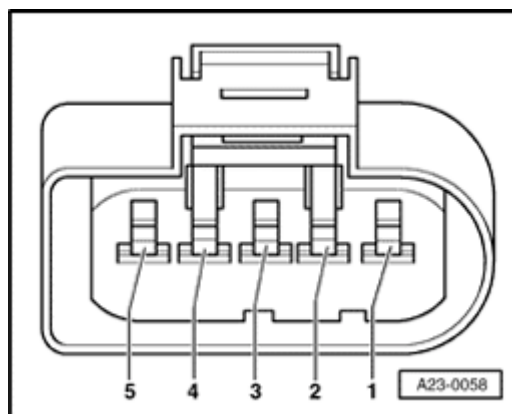

A

- Check following wire connections for open circuit and short circuit to Ground (GND) and B+:

Harness connector	VAG1598/31 test box
Terminal	Socket
3	27
4	53
5	29

- Repair open circuit or short circuit if necessary.
- Also check all wires for short circuit to each other.

If wire connection is OK:

- Replace Mass Air Flow (MAF) sensor -G70-.

Intake system, checking for leaks (unmetered air)

Special tools and equipment

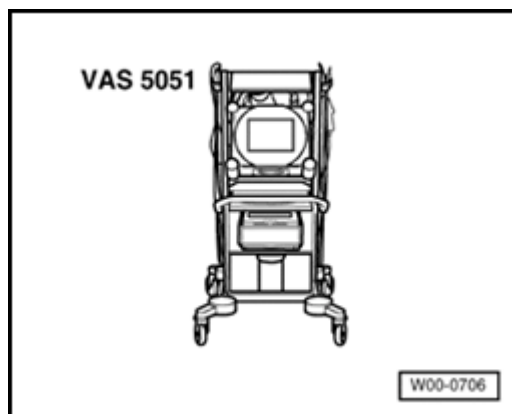

- ◆ VAS5051 with VAG5051/1
- or
- ◆ VAG1551 with VAG1551/3A
- ◆ Engine leak detection spray G 001 800 A1

Note:

- ◆ *The negative pressure in the intake system sucks in the leak detection spray with the unmetered air. Leak detection spray decreases ignition quality and performance of the fuel mixture. This causes a reduction in engine speed and a sharp increase of CO content.*
- ◆ *It is absolutely necessary to follow the safety precautions listed on the can.*

Test sequence

- Connect VAS5051 tester or VAG1551 scan tool and select control module for engine electronics using "address word" 01 ⇒ [Page 01-10](#) . Engine must run at idle.

Rapid data transfer HELP
Select function XX

⏪ When indicated on display

- Press buttons -0- and -8- to select "Read Measuring Value Block" and press -Q- button to confirm input.

Read measuring value block Q
Enter display group number XXX

⏪ When indicated on display

- Press buttons -0-, -0- and -1- to select "display group number 001" and press -Q- button to confirm input.

Read Measuring Value Block 1 →
1 2 3 4

⏪ Indicated on display(1 to 4 = display fields)

- Make note of engine speed in display field 1.
- Spray intake system parts with engine leak detection spray in a systematic manner.

If engine speed decreases:

- Check sprayed part of intake system for leaks, and eliminate error.

Rapid data transfer

HELP

Select function XX

- Press → button.



Indicated on display (function selection):

- Press buttons -0- and -6- to select "End output" and press -Q- button to confirm input.
- Switch ignition off.