

## Throttle valve control module, checking

### Notes:

- ◆ *If the throttle valve control module -J338- is removed and installed, or replaced, adaptation of the throttle valve control module to the Motronic ECM is required ⇒ [page 24-150](#) .*
- ◆ *Component locations ⇒ [page 24-1](#)*

### Required special tools and test equipment

- VAG1551 or VAG1552 Scan Tool (ST) with VAG1551/3 adapter cable
- VAG1598/22 test box
- Multimeter US1119 (Fluke 83 or equivalent)
- VW1594 connector test kit
- Wiring diagrams

## Function

Idle speed stabilization is integrated in the throttle valve control module -J338-. In the housing opposite the throttle valve are Throttle Position (TP) sensor -G69-, Closed Throttle Position (CTP) switch -F60-, throttle drive -G186- and angle sensor -1- for throttle drive -G187-.

### **The housing should not be opened.**

The individual components cannot be replaced or mechanically adjusted. All adjustments are accomplished by the VAG1551 Scan Tool (ST) using the "Basic Setting" function 04.

If the complete throttle valve control module is without power (i.e. disconnected), the throttle valve assumes a mechanical closed throttle position that results in an increased idle speed of 1200-1300 RPM (with engine at operating temperature).

If only the Throttle Position (TP) actuator -V60- is without power, the throttle valve also assumes a mechanical closed throttle position (limp-home position), but because the signal from the CTP switch -F60- can still be recognized, a nearly "normal" idle speed of approx. 900 RPM is maintained with a corresponding reduction of the ignition timing advance.

If the Engine Control Module (ECM) recognizes a

malfunction in the angle sensor -1- for throttle drive -G187-, it switches the power off for throttle drive -G186-, and the throttle valve again assumes the mechanical closed throttle position (limp-home position).

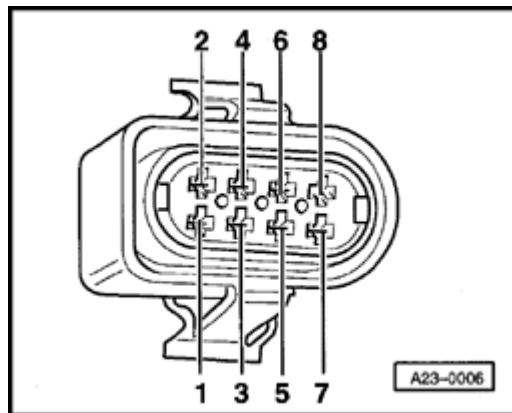

### Throttle valve control module power supply, checking

A

- Disconnect 8-pin harness connector from throttle valve control module -J338-.
- Connect multimeter US1119 (Fluke 83 or equivalent) between harness connector terminals using adapter cables from VW1594 connector test kit.
- Switch ignition on, and check voltage. Specified values:
  - ◆ Connector terminals 3 and 7 (Ground): 9.0-14.5 volts
  - ◆ Connector terminals 4 and 7 (Ground): 4.0-6.0 volts
- Switch ignition off.

If voltage is NOT OK:

- Connect VAG1598/22 test box ⇒ [page 01-67](#) .
- Check wiring for open circuit between ECM/test box and 8-pin harness connector.
  - ◆ Connector terminal 3 to ECM/test box socket 69
  - ◆ Connector terminal 4 to ECM/test box socket 62
  - ◆ Connector terminal 7 to ECM/test box socket 67
  - ◆ Specified value: max. 1.5  $\Omega$

24-131

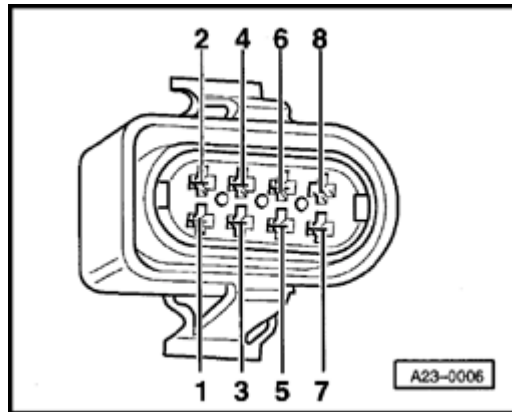

A

- Check wiring for short circuit between ECM/test box and 8-pin harness connector.
  - ◆ Connector terminal 7 to ECM/test box socket 69
  - ◆ Connector terminal 7 to ECM/test box socket 62
  - ◆ Connector terminal 4 to ECM/test box socket 67
  - ◆ Specified value:  $\infty \Omega$
- Reconnect throttle valve control module harness connector.

If wiring is OK:

- Replace Motronic Engine Control Module (ECM) -J220- ⇒ [page 01-68](#) .
- Carry out adaptation of throttle valve control module to ECM ⇒ [page 24-150](#) .
- Check readiness code ⇒ [page 01-70](#) . If Diagnostic Trouble Code (DTC) memory has been erased, or ECM was disconnected, generate new readiness code ⇒ [page 01-73](#) .

## Closed Throttle Position (CTP) switch, checking

### **Note:**

*The Closed Throttle Position (CTP) switch -F60- is inside the throttle valve control module -J338-.*

### **Test conditions**

- Throttle valve in closed throttle position; if necessary adjust accelerator pedal cable

⇒ [Repair Manual, Fuel Supply System, Repair Group 20](#)

- Cruise control adjustment OK
- Power supply for throttle valve control module OK; checking ⇒ [page 24-130](#)

### **Checking**

- Connect VAG1551 or VAG1552 scan tool and press buttons -0- and -1- to insert "Engine Electronics" address word 01 (with engine running at idle) ⇒ [page 01-8](#) .

Rapid data transfer      HELP  
Select function XX

◀ Indicated on display

- Press buttons -0- and -8- to select "Read Measuring Value Block" function 08, and press -Q- button to confirm input.

Read Measuring Value Block      HELP  
Input display group number XXX

◀ Indicated on display

24-133

- Press buttons -0-, -0- and -5- to input display group number 5 (005), and press -Q- button to confirm input.

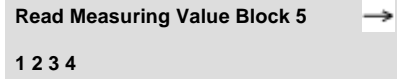

Indicated on display (1-4 = display fields)

- Check Closed Throttle Position (CTP) switch (display field 4):

	Display fields			
	1	2	3	4
<b>Display group 5: Engine electronics</b>				
Display	xxx RPM	xx.xx ms	xxx km/h	Idle Part throt Full throt Decel Enrich
Indicates	Engine speed (in 40 RPM steps)	Engine load	Vehicle speed	Operational condition
Range	0 - 6800 RPM	0.00 - 12.75 ms	---	---
Specified value	620 - 740 RPM (all-wheel drive)	1.00 - 2.50 ms	0 km/h	Throttle closed: "Idle"



	740 - 860 RPM (front-wheel drive)			
				Throttle slightly open: "Part throt"
	---	---	---	If display is NOT OK ⇒ <a href="#">page 24-134</a> , Continuation

**Continuation**

- Switch ignition off.
- Connect VAG1598/22 test box to ECM harness connector ⇒ [page 01-67](#) .
- Connect multimeter US1119 (Fluke 83 or similar) and check resistance between test box sockets 67 and 69.

Specified value: max. 5.0  $\Omega$

- Open throttle slowly.

Specified value:  $\infty \Omega$

If resistance is NOT OK:

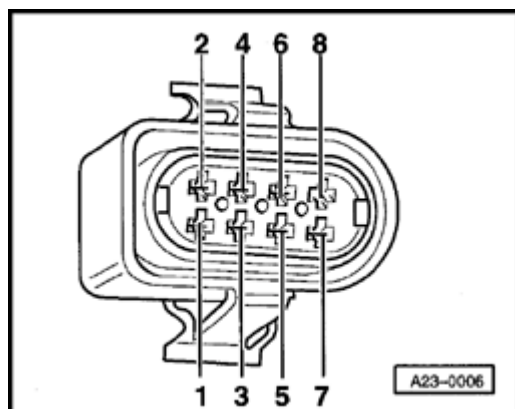

A

- Disconnect 8-pin harness connector for throttle valve control module - J338-.
- Check wiring for open circuit between ECM/test box and 8-pin harness connector.
  - ◆ Connector terminal 3 to ECM/test box socket 69
  - ◆ Connector terminal 7 to ECM/test box socket 67
  - ◆ Specified value: max. 1.5  $\Omega$

24-135

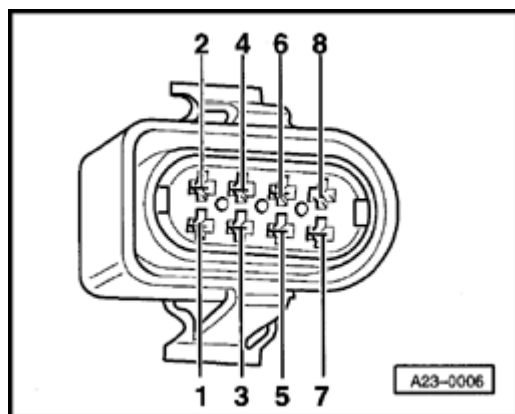

A

- Check wiring for short circuit between ECM/test box and 8-pin harness connector.
  - ◆ Connector terminal 7 to ECM/test box socket 69
  - ◆ Specified value:  $\infty \Omega$
- Reconnect throttle valve control module harness connector.

If wiring is OK:

- Replace throttle valve control module -J338-.
- Carry out adaptation of throttle valve control module to ECM  $\Rightarrow$  [page 24-150](#) .
- Check readiness code  $\Rightarrow$  [page 01-70](#) . If Diagnostic Trouble Code (DTC) memory has been erased, or ECM was disconnected, generate new readiness code  $\Rightarrow$  [page 01-73](#) .

## Throttle drive and angle sensor for throttle drive, checking

### Note:

*Throttle drive -G186- and angle sensor -1- for throttle drive -G187- are located in the throttle valve control module -J338-.*

### Test conditions

- Throttle valve in closed throttle position; if necessary adjust accelerator pedal cable

⇒ [Repair Manual, Fuel Supply System, Repair Group 20](#)

- Cruise control adjustment OK
- Power supply for throttle valve control module OK; checking ⇒ [page 24-130](#)
- Engine coolant temperature at least 80 ° C (176 ° F)
- Automatic transmission selector lever in "P" or "N"

## Checking

- Connect VAG1551 or VAG1552 scan tool and press buttons -0- and -1- to insert "Engine Electronics" address word 01 (with engine running at idle) ⇒ [page 01-8](#) .

Rapid data transfer      HELP  
Select function XX

↖ Indicated on display

- Press buttons -0- and -8- to select "Read Measuring Value Block" function 08, and press -Q- button to confirm input.

Read Measuring Value Block      HELP  
Input display group number XXX

↖ Indicated on display

- Press buttons -0-, -5- and -5- to input display group number 55 (055), and press -Q- button to confirm input.

Read Measuring Value Block 55      →  
1 2 3 4

↖ Indicated on display (1-4 = display fields)

- Compare display with specified values for idle air control (display fields 1-4):

24-138

	Display fields			
	1	2	3	4
<b>Display group 55: Idle control</b>				
Display	xxx RPM	x.xx g/s	x.xx g/s	xxxx
Indicates	Engine speed RPM (in steps of 10 RPM)	Regulating value-idle mass air flow (idle air control)	Learning value-idle mass air flow	Operating conditions
Range	0 - 2550 RPM	-2.78 to +2.85 g/s	-1.67 to +3.34 g/s	---
Specified value	620 - 740 RPM  (all-wheel drive)  or  740 - 860 RPM  (front-wheel drive)	-1.39 to +1.39 g/s	-1.39 to +1.39 g/s	0000  (all-wheel drive)  and/or  0100  (front-wheel drive)
	If engine speed is NOT OK ⇒ <a href="#">page 24-141</a> , Continuation	If display is NOT OK ⇒ <a href="#">page 24-139</a> , Evaluation of display group 55		Explanation ⇒ <a href="#">page 24-140</a>

If displayed values are OK:

- Press → button.

- Press buttons -0- and -6- to select "End Output" function 06, and press -Q- button to confirm input.
- Switch ignition off.

### Evaluation of display group 55

Display group: 55	Possible malfunction cause	Corrective action
Display fields: 2 + 3		
above 1.39 g/s	<ul style="list-style-type: none"> <li>◆ Increased load because of switched-on consumers</li> </ul>	<ul style="list-style-type: none"> <li>- Switch off electrical consumers</li> </ul>
	<ul style="list-style-type: none"> <li>◆ Throttle valve mechanism sticking</li> <li>◆ Air passage in area of throttle valve contaminated</li> </ul>	<ul style="list-style-type: none"> <li>- Visually check, repair if necessary</li> </ul>
below -1.39 g/s	<ul style="list-style-type: none"> <li>◆ Intake air leak (false air) behind throttle valve</li> </ul>	<ul style="list-style-type: none"> <li>- Check intake air system for leaks (false air) ⇒ <a href="#">page 24-126</a></li> <li>- Check exhaust system ⇒ Repair Manual, 2.8 Liter V6 5V General, Engine, Repair Group 26</li> </ul>



**Explanation of 4-digit display**

Explanation when display field is = 0				
x	x	x	x	Display group 55
			0	A/C compressor off (0 = A/C compressor off; 1 = A/C compressor on)
		0		Shift lever in P or N (0 = Shift lever in P or N; 1 = Shift lever in 2/3/4/R/D)
	0			Idle air control boost (0 = no idle air control boost, for all-wheel drive vehicles; 1 = idle air control boost, for front-wheel drive vehicles)
0				always "0"
<p><b>Note:</b></p> <p><i>The increased idle speed (raised rpm) on vehicles with front-wheel drive is attained if there is power supplied (B+, 15er) to terminal 10 of the engine control module.</i></p>				

### Continuation

- Switch ignition off.
- Connect VAG1598/22 test box to ECM harness connector ⇒ [page 01-67](#) .
- Switch ignition on.
- With throttle valve in closed throttle position, connect multimeter US1119 (Fluke 83 or equivalent), and check resistance between ECM/test box sockets 59 and 66.

Specified value: 3-200  $\Omega$

If resistance is NOT OK:

- Disconnect 8-pin harness connector from throttle valve control module -J338-.
- Check wiring for open circuit between ECM/test box and 8-pin throttle valve control module harness connector.
  - ◆ Connector terminal 1 to ECM/test box socket 66
  - ◆ Connector terminal 2 to ECM/test box socket 59
  - ◆ Connector terminal 7 to ECM/test box socket 67

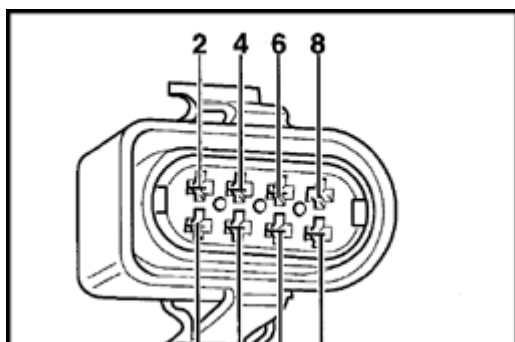

A

- ◆ Connector terminal 8 to ECM/test box socket 74
- ◆ Specified value: max. 1.5  $\Omega$

24-142

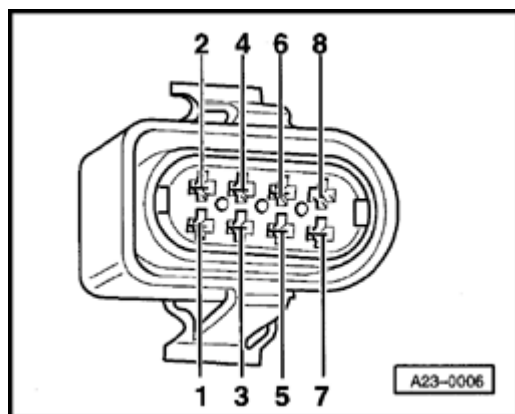

A

- Check wiring of 8-pin connector for short circuit between wires, according to wiring diagram.
  - ◆ Connector terminal 1 to ECM/test box socket 59
  - ◆ Connector terminal 1 to ECM/test box socket 74
  - ◆ Connector terminal 1 to ECM/test box socket 67
  - ◆ Connector terminal 2 to ECM/test box socket 67
  - ◆ Connector terminal 2 to ECM/test box socket 74
  - ◆ Connector terminal 7 to ECM/test box socket 74
  - ◆ Specified value:  $\infty \Omega$

If wiring is OK:

- Carry out adaptation of throttle valve control module to ECM  $\Rightarrow$  [page 24-150](#) .
- Check readiness code  $\Rightarrow$  [page 01-70](#) . If Diagnostic Trouble Code (DTC) memory has been erased, or ECM was disconnected, generate new readiness code  $\Rightarrow$  [page 01-73](#) .

## Throttle Position (TP) sensor, checking

### Note:

*The Throttle Position (TP) sensor -G69- is located inside the throttle valve control module - J338-.*

### Test conditions

- Throttle valve in closed throttle position; if necessary adjust accelerator pedal cable

⇒ [Repair Manual, Fuel Supply System, Repair Group 20](#)

- Cruise control adjustment OK
- Power supply for throttle valve control module OK; checking ⇒ [page 24-130](#)

### Checking

- Connect VAG1551 or VAG1552 scan tool and press buttons -0- and -1- to insert "Engine Electronics" address word 01 (with ignition switched; engine not running) ⇒ [page 01-8](#) .

Rapid data transfer      HELP  
Select function XX

◀ Indicated on display

- Press buttons -0- and -8- to select "Read Measuring Value Block" function 08, and press -Q- button to confirm input.

Read Measuring Value Block      HELP  
Input display group number XXX

◀ Indicated on display

24-144

- Press buttons -0-, -0- and -3- to input display group number 3 (003), and press -Q- button to confirm input.

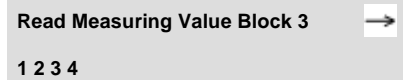

Indicated on display (1-4 = display fields)

- Compare display with specified values for throttle angle, (display field 3):

	Display fields			
	1	2	3	4
<b>Display group 3: Load measurement</b>				
Display	xxx RPM	xx.x g/s	xxx ∠ °	xx.x ° BTDC
Indicates	Engine speed (in 40 RPM steps)	Mass air flow	Throttle angle	Ignition timing
Range	0 - 6800 RPM	---	0 - 90 ∠ °	0.0 ° - 50.0 ° BTDC
Specified value	0 RPM	---	0 - 5 ∠ °	0.0 °
	---	---	If not as specified ⇒ <a href="#">page 24-146</a> , Evaluation of display group 3	---

- Open throttle valve slowly while monitoring degree ( ° ) value in display field 3.  
Value must increase uniformly over the entire range.

- Press → button.



- Press buttons -0- and -6- to select "End Output" function 06, and press -Q- button to confirm input.
- Switch ignition off.

**Note:**

*The values displayed in display field 3 depend on the calibration of the Throttle Position (TP) sensor and do not correspond with the actual throttle valve opening in degrees. The maximum displayed value is 90.0 °.*

If the throttle angle value does not increase uniformly:

- Replace throttle valve control module -J338-.
- Carry out adaptation of throttle valve control module to ECM ⇒ [page 24-150](#) .
- Check readiness code ⇒ [page 01-70](#) . If Diagnostic Trouble Code (DTC) memory has been erased, or ECM was disconnected, generate new readiness code ⇒ [page 01-73](#) .

24-146

**Evaluation of display group 3**

Display group: 3	Possible malfunction cause	Corrective action
Display field: 3		
0.0 $\angle^\circ$	<ul style="list-style-type: none"> <li>◆ Open circuit or short circuit to B+ in signal wire between throttle position sensor -G69- and engine control module</li> <li>◆ Malfunction in Ground for -G69-</li> </ul>	- Check wiring ⇒ <a href="#">page 24-147</a>
99.0 $\angle^\circ$	<ul style="list-style-type: none"> <li>◆ Short circuit to Ground in signal wire between throttle position sensor -G69- and engine control module</li> <li>◆ Malfunction in voltage supply for -G69-</li> </ul>	

### Checking wiring

- Connect VAG1598/22 test box to ECM harness connector ⇒ [page 01-67](#) .
- Connect multimeter US1119 (Fluke 83 or equivalent), using adapter cables from VW1594 connector test kit.
- Measure resistance to check for short circuit between test box sockets 2 (Ground) and 75 (signal wire).
  - ◆ Test box sockets 2 and 75
  - ◆ Specified value:  $\infty \Omega$
- Switch multimeter to voltage (20 VDC) measuring range.
- Switch ignition on.
- Check wiring for short circuit to B+.

Note voltage reading if applicable (if not 0 volts).

- Switch ignition off.
- Continue test, depending on whether or not voltage was measured ⇒ [page 24-148](#) or page ⇒ [Page 24-149](#) .

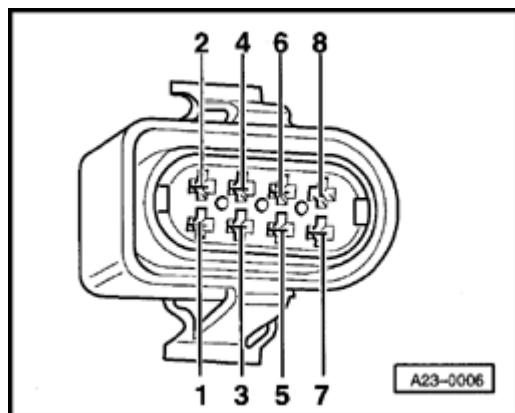

### Continuation (with measured voltage)

A

- Disconnect 8-pin harness connector from throttle valve control module -J338-.

If measured voltage was approx. 5 volts:

- Connect multimeter US1119 (Fluke 83 or equivalent), using adapter cables from VW1594 connector test kit.
- Measure resistance to check for short circuit between test box sockets 62 (power supply) and 75 (signal wire).
  - ◆ Test box sockets 62 and 75
  - ◆ Specified value:  $\infty \Omega$

If measured voltage was approx. battery positive voltage (B+):

- Check wiring at 8-pin connector, terminal 5 for short circuit to battery B+.

**Continuation (with no measured voltage)**

- Disconnect 8-pin harness connector from throttle valve control module -J338-.

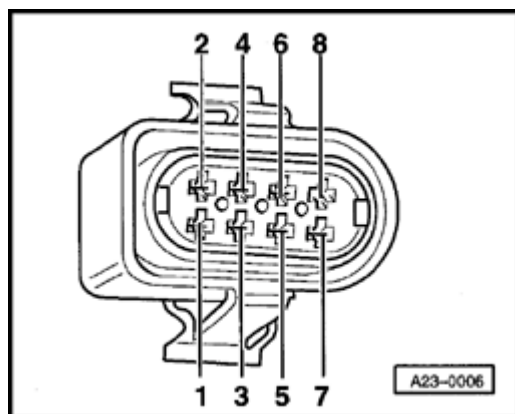

A

- Check wiring for open circuit between ECM/test box and 8-pin harness connector.
  - ◆ Connector terminal 5 to ECM/test box socket 75
  - ◆ Specified value: max. 1.5  $\Omega$

If wiring is OK:

- Replace throttle valve control module -J338-.
- Carry out adaptation of throttle valve control module to ECM  $\Rightarrow$  [page 24-150](#) .
- Check readiness code  $\Rightarrow$  [page 01-70](#) . If Diagnostic Trouble Code (DTC) memory has been erased, or ECM was disconnected, generate new readiness code  $\Rightarrow$  [page 01-73](#) .

## **Throttle valve control module, adaptation to Engine Control Module (ECM)**

If the throttle valve control module -J338- is removed and installed, or replaced, adaptation of the throttle valve control module to the Motronic ECM is required.

During "adaptation" with ignition switched on and the engine not running, the Motronic ECM "learns" the closed throttle position (CTP), wide open throttle (WOT) and other positions of the throttle valve control module, and a characteristic curve of the relationship between Throttle Position (TP) sensor -G69- and angle sensor for throttle drive -G187-.

### **Required special tools and test equipment**

- VAG1551 or VAG1552 Scan Tool (ST) with VAG1551/3 adapter cable

### **Test conditions**

- No malfunctions stored in DTC memory ⇒ [page 01-16](#)
- Throttle valve in closed throttle position; if necessary adjust accelerator pedal cable

⇒ [Repair Manual, Fuel Supply System, Repair Group 20](#)

- Cruise control adjustment OK
- Power supply for throttle valve control module OK; checking ⇒ [page 24-130](#)



### Test procedure

- Connect VAG1551 or VAG1552 scan tool and press buttons -0- and -1- to insert "Engine Electronics" address word 01 (with ignition switched on; engine not running) ⇒ [page 01-8](#) .

Rapid data transfer      HELP  
Select function XX

↖ Indicated on display

- Press buttons -0- and -4- to select "Basic Setting" function 04, and press -Q- button to confirm input.

System in Basic Setting      HELP  
Input display group number XXX

↖ Indicated on display

- Press buttons -0-, -6- and -0- to input display group number 60 (060), and press -Q- button to confirm input.

System in Basic Setting 60      →  
1 2 3 4

↖ Indicated on display (1-4 = display fields)

#### Notes:

- ◆ *After confirming input of display group 60, adaptation is started. The Throttle Position (TP) sensor is positioned in the closed throttle, wide open throttle and limp-home positions. Following this procedure, other intermediate steps will create a characteristic curve of the relationship between Throttle Position (TP) sensor -G69- and angle sensor for throttle drive -G187-.*
- ◆ *The Motronic ECM stores these values in permanent memory. Afterward, the throttle valve assumes the starting position.*

24-152

- Compare display with specified values (display fields 1-4):

	Display fields			
	1	2	3	4
<b>Display group 60: Basic setting-throttle valve control module</b>				
Display	xxx ∟°	xxx ∟°	Idle Part throt Full throt Decel Enrich	ADP runs ADP. OK ADP. ERROR
Indicates	Throttle valve angle	Throttle drive angle	Operating condition	Adaptation condition
Range	0 - 90 ∟°	---	---	---
Specified value	1 - 10 ∟° (automatic trans.)	---	Idle	ADP. runs
	1 - 20 ∟° (manual trans.)	---	---	---
	0 - 5 ∟°	0 - 5 ∟°	Idle	ADP. OK

				(ADP. ERROR indicates unsuccessful adaptation)
		If displayed values are NOT OK:  - Check DTC memory ( ⇒ <a href="#">page 01-16</a> )  - Check throttle valve control module ( ⇒ <a href="#">page 24-128</a> )		

- End adaptation as soon as possible after 30 seconds by pressing → button.

If displayed values are OK:

- Press buttons -0- and -6- to select "End Output" function 06, and press -Q- button to confirm input.