

24-81

## Mass Air Flow (MAF) sensor, checking

### Notes:

- ◆ To functionally check the Mass Air Flow (MAF) sensor ⇒ Repair Group 01, Basic setting, display group 001, display field 2.
- ◆ Component locations ⇒ [page 24-1](#) .

### Checking voltage supply

- Mass Air Flow (MAF) sensor fuse OK

- Disconnect MAF sensor harness connector.

- Switch multimeter (Fluke 83 or equivalent) to measure voltage and connect between connector terminals 2 (GND) and 3 (B+) using jumper wires from connector test kit VW 1594.

- Switch ignition ON.

Specified value: approx. 12 to 14 volts

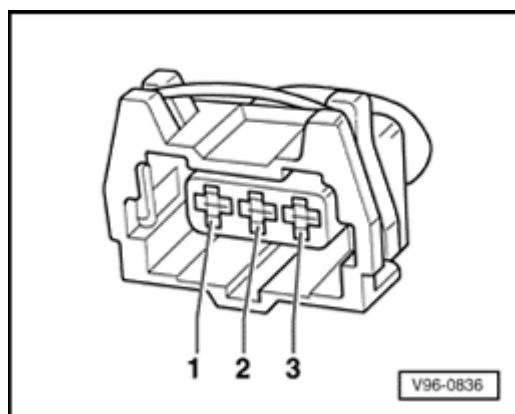

---

**24-82**

If the specified value is not obtained, perform the following tests:

- Check Mass Air Flow (MAF) sensor fuse.
- Check wiring for continuity between terminal 3 and fuse using wiring diagram.

Specified value: max. 0.5 ohms( $\Omega$ )

- Check wiring for continuity between terminal 2 and intake manifold Ground (GND).

Specified value: max. 0.5  $\Omega$

### Checking signal wire

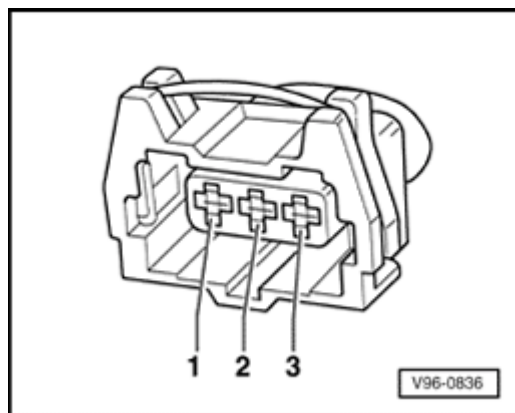

A

- Connect VAG 1598/19 test box to ECM harness connector ⇒ [page 01-255](#) .
- Check signal wire for continuity between MAF sensor connector terminal 1 and test box socket A12.

Specified value: max.1.0 Ω

If the specified value is not obtained:

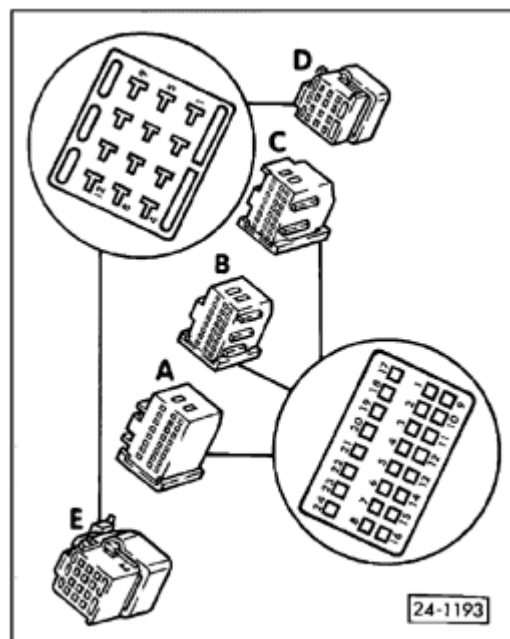

A

- Find short circuit or open circuit; repair as necessary.

MAF sensor connector terminal	ECM connector A terminal
1	A12

#### Note:

*If it becomes necessary to repair or replace any of the Mass Air Flow (MAF) sensor electrical terminals, ONLY replace with gold-plated terminals.*

### Checking function

- Slide back protective boot from back of MAF sensor connector (leaving it connected).

#### **Note:**

*The connector pin numbers are marked on the back of the connector itself.*

- Switch multimeter (Fluke 83 or equivalent) to measure voltage and connect between terminal 2 (GND) and terminal 1 (B+) using jumper wires from connector test kit VW 1594.
- Switch ignition ON.

Specified value: 0.3 to 1.1 volts

- Start engine and let idle.
- Switch off all electrical consumers (engine coolant fan should not run during measurement).

Continuously vary engine speed between idle and 4000 RPM.

Specified value: 1.5 volts minimum to 3.4 volts

max. depending on engine speed (RPM)

If the specified value is not obtained:

- Replace Mass Air Flow (MAF) sensor.