

Workshop Manual Audi 100 1983 ▶, Audi 200 1984 ▶

Engine Code letters	3B								
Booklet		5 Cylinder F. I. engine (4 valve), mechanics							

Edition 05.89

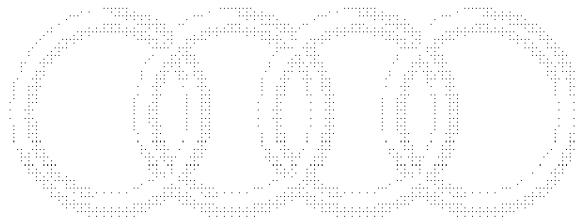

Audi

Protected by copyright. Copying or reuse for commercial purposes, in part or in whole, is not permitted unless authorized by AUDI AG. AUDI AG does not guarantee or accept any liability with respect to the correctness of information in this document. Copyright by AUDI AG



V·A·G

Index

00 Technical data	Page
- Engine number	00-1
- List of engines	00-2
13 Crankshaft group	Page
Dismantling and assembling engine	13-1
- Installing toothed belt	13-7
- Tensioning alternator vee belt	13-11
- Tensioning central hydraulic pump vee belt	13-12
Dismantling and assembling cylinder block, crankshaft and flywheel	13-13
- Checking crankshaft radial clearance	13-21
- Crankshaft dimensions	13-22
- Inserting pin for ignition timing point	13-23
Dismantling and assembling pistons and conrods	13-26
- Checking conrod radial clearance	13-35
15 Cylinder head, Valve gear	Page
- Removing and installing cylinder head	15-1
- Checking compression pressure	15-6
- Servicing valve gear	15-7
- Reworking valve seats	15-13
- Checking hydraulic tappets	15-15
- Renewing camshaft oil seal	15-17
- Removing and installing camshaft	15-19
- Checking and renewing valve guides	15-22
- Renewing valve stem seals (cylinder head fitted)	15-25
- Renewing valve stem seals (cylinder head removed)	15-27
17 Lubrication	Page
Removing and installing parts of the lubrication system	17-1
- Removing oil pump	17-9
- Checking oil pressure and oil pressure switch	17-13
- Checking oil pressure sender	17-15

Index

	Page
19 Cooling	
Removing and installing parts of the cooling system	19-1
- Checking cooling system for leaks	19-5
- Draining and filling with coolant	19-6
- Checking thermo switch and coolant pump for exhaust turbocharger	19-10
20 Fuel supply system	
Removing and installing parts of the fuel supply system	20-1
- Rules for cleanliness when working on the fuel supply system	20-4
- Connecting remote control V.A.G 1348/3A with adapter cable V.A.G 1348/3-2	20-5
- Fitting position fuel filter	20-5
- Removing and installing fuel gauge sender	20-6
- Removing and installing fuel pump	20-8
- Dismantling and assembling fuel pump	20-11
- Checking fuel pump	20-12
- Checking delivery rate of electric fuel pump	20-14
- Checking electric fuel pump non-return valve	20-16
- Renewing non-return valve	20-21
- Checking fuel pump relay and control circuit	20-22
- Repairing activated charcoal filter tank venting system	20-25
- Repairing throttle linkage	20-26
- Adjusting throttle cable	20-28
- Checking and adjusting throttle damper	20-31
21 Exhaust gas turbocharging	
Removing and installing parts of the turbocharger	21-1
Removing and installing charge air cooler and crankcase ventilation components	21-3
- Removing and installing turbocharger	21-5
- Removing and installing charge air cooler	21-13
- Checking turbocharger and air dump valve	21-18
- Checking overrun cut-off valve with vacuum pump V A.G 1390	21-21
Protected by copyright. Copying for private or commercial purposes in part or in whole is not permitted unless authorized by AUDI AG. AUDI AG does not guarantee or accept any liability with respect to the correctness of information in this document. Copyright by AUDI AG.	
26 Exhaust system	
Removing and installing parts of the exhaust system	26-1
- Joint between main and rear silencer	26-3
- Aligning exhaust system stress free	26-3
- Removing and installing exhaust manifold	26-4
- Checking exhaust system for leaks	26-13

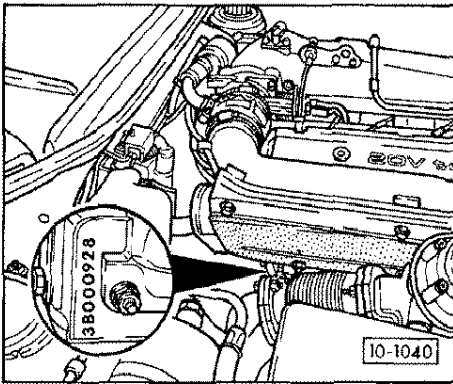

TECHNICAL DATA
=====

ENGINE CODE AND SERIAL NUMBER

← Engine code and serial number are stamped on the right hand side at the rear of the cylinder head.

00-1

LIST OF ENGINES

Engine code		3 B	
Engine characteristics			
Manufactured	from 09.88 to		Valve timing for 1mm valve lift and 0 mm valve clearance
No. of cylinders	5		Inlet opens after TDC 3° Inlet closes after BDC 25° Outlet opens before BDC 42° Outlet closes before TDC 9°
Capacity	l 2.226		RON min. 95
Output	kW/rpm 162/5700		(unleaded) Motronic
Torque	Nm/rpm 309/1950		Exhaust gas recirculation ---
Bore	mm ø 81		Catalytic converter 2 x
Stroke	mm 86.4		Lambda control x
Compression ratio	9.3		Turbocharger x
		Vehicle is specially tuned for:	Low pollutant exhaust

Protected by copyright. This document is for commercial purposes, in part or in whole, is not permitted unless authorized by AUDI AG. AUDI AG does not guarantee or accept any liability with respect to the correctness of information in this document. Copyright by AUDI AG.

00-2

DISMANTLING AND ASSEMBLING ENGINE

=====

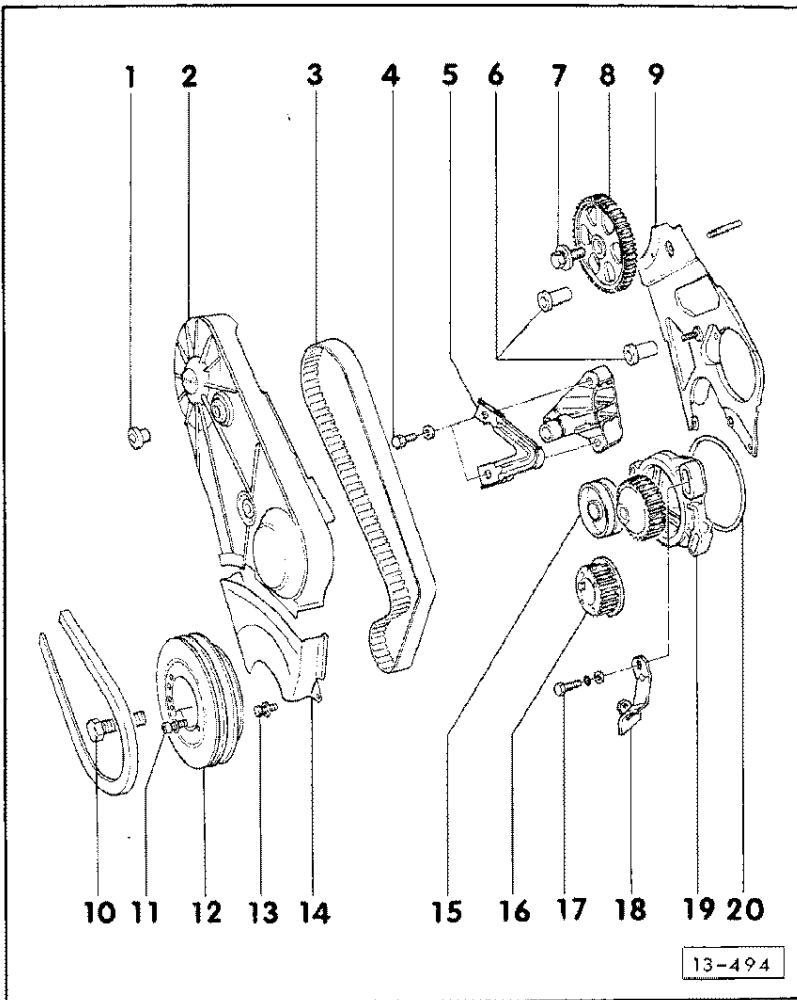

Note:

- Always renew all seals, gaskets and oil seals on shafts
- See manual gearbox assembly for repairs to clutch
- Removing and installing sump - Figs. 3 and 4
- Checking compression - Repair Group 15

1- 10 Nm

2- Toothed belt guard, upper

3- Toothed belt

- Installing - page 13-7
- Turn coolant pump to left to tension - page 13-9

4- 43 Nm

5- Vee-Belt deflection limiter (right)

6- Spacer bushes

- Long spacer bush (top)
- Short spacer bush (bottom)

7- 67 Nm

8- Camshaft sprocket

13-1

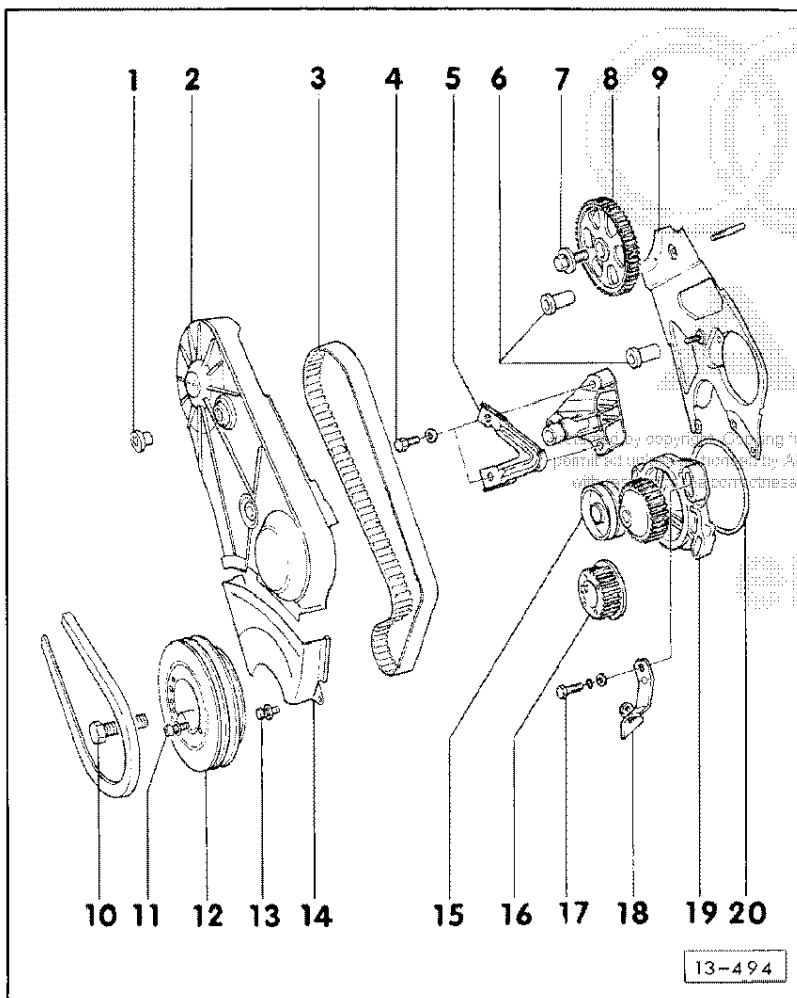

9- Toothed belt cover, rear

10- 350 Nm - Fig. 1

11- 22 Nm

12- Vibration damper

- Note method of securing when fitting to toothed belt sprocket, position when fitting toothed belt - page 13-9
- Assembly of vibration damper with crankshaft toothed belt sprocket only possible in one position - holes offset

13- 10 Nm

14- Toothed belt guard, lower

15- Idler pulley

- Removing - Fig. 2
- When installing, tighten to 10 Nm

16- Toothed belt sprocket

- Crankshaft

17- 22 Nm

18- Vee-belt deflection limiter (left)

19- Coolant pump

- Turn to left to tension toothed belt - page 13-9

20- 'O' ring

13-2

DISMANTLING AND ASSEMBLING ENGINE

=====

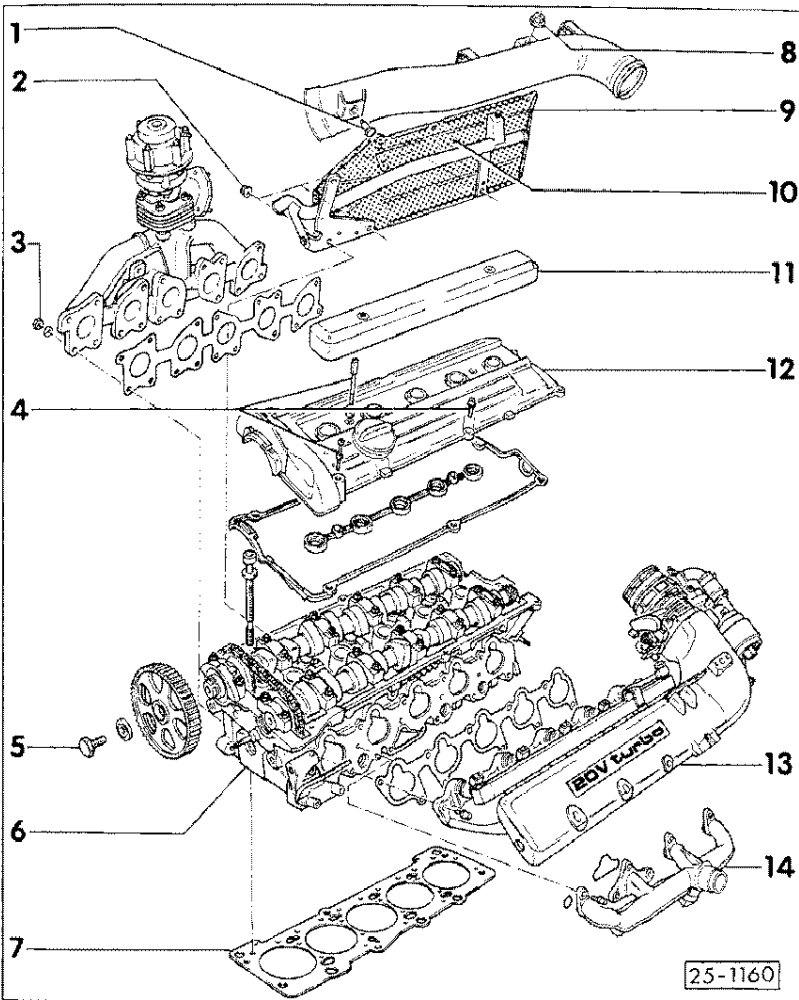

- 1- 22 Nm
- 2- 22 Nm
- 3- 25 Nm
- 4- 10 Nm
- 5- 67 Nm
- 6- Cylinder head
 - Removing and refitting - repair group 15
- 7- Cylinder head gasket
 - Ensure correct installation position. The marking "OBEN" or the part number must face the cylinder head.
 - Fit over locating pin in cylinder block.
- 8- 22 Nm
- 9- Heat shield
- 10- Crankcase breather pipe
- 11- Ignition cable cover

13-3

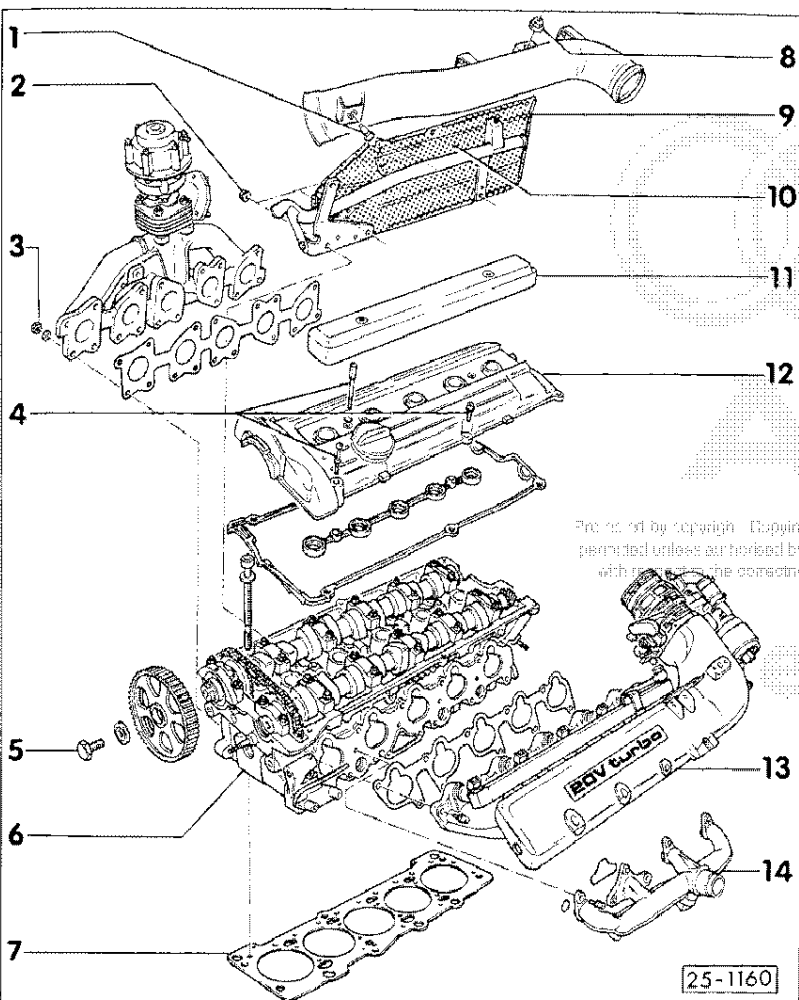

- 12- Cylinder head cover
 - Remove throttle valve housing before removing cylinder head cover.
- 13- Induction manifold
 - Tighten securing bolts to 22 Nm.
 - Use hex key V.A.G 1669 for removal and installation.

Vehicles equipped with CCS cruise control:

 - Remove CCS vacuum unit before removing the induction manifold - see page 13-10.
- 14- Coolant manifold
 - Tighten securing bolts to 10 Nm.

Printed by copyright. Copying for private or commercial purposes, in part or in whole, is not permitted unless authorized by AUDI AG. AUDI AG does not guarantee or accept any liability with respect to the correctness of information in this document. Copyright by AUDI AG.



13-4

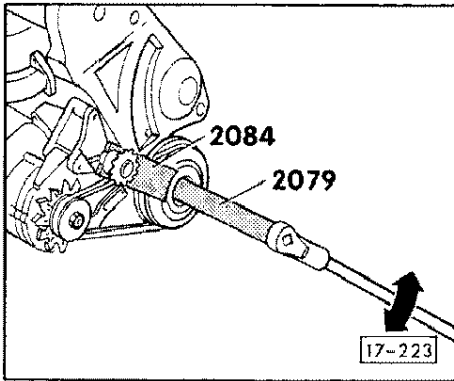

◀ Fig. 1 Removing and installing vibration damper

- Tightening torque 350 Nm.
- Use special tools 2079 and 2084.
- Coat threads and contact surface of bolt head with anti-corrosion compound AMV 188 000 02.

Caution

The tightening torque applies when using the special tool 2079 and this tool must be flush with the torque wrench during this operation.

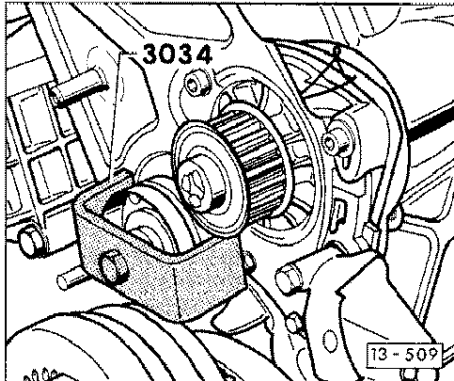

◀ Fig. 2 Removing idler pulley using 3034

13-5

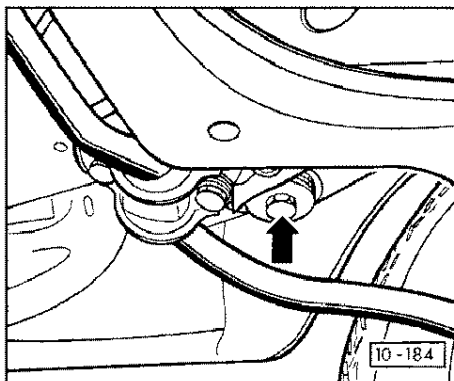

◀ Fig. 3 Removing and installing oil sump

Caution

The subframe will suddenly drop approx. 100mm.

To remove sump remove the two front bolts securing the subframe.

Caution

Renew these two subframe bolts when refitting.

During refitting the two subframe bolts should be tightened to 65 Nm and further tightened a quarter turn.

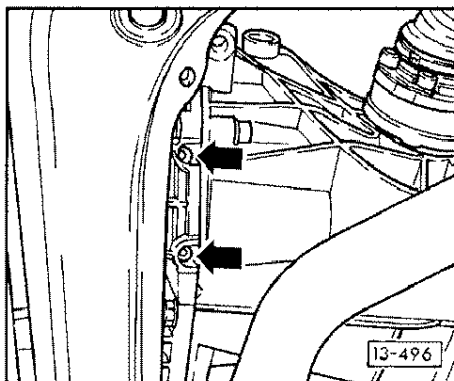

◀ Fig. 4

- There are two cutouts on the flywheel side of the sump (see arrows). The bolts accessible through these cutouts are 5mm hexagon socket head bolts.
- When installing the sump tighten all bolts by hand and then tighten M6 bolts to 10 Nm and M8 bolts to 22 Nm.

13-6

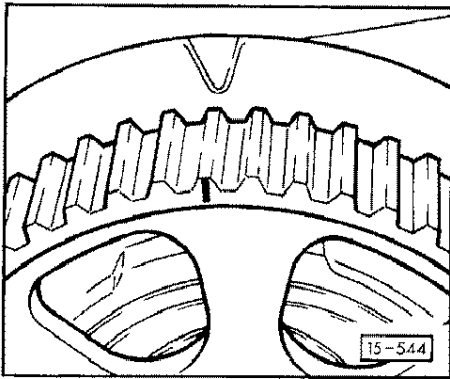

INSTALLING TOOTHED BELT

Cylinder head cover in situ

- ▶ - Mark on camshaft sprocket must align with arrow on cylinder head cover.

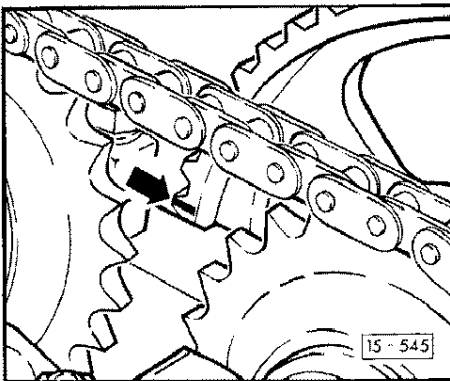

Cylinder head cover off

- Mark on camshaft sprocket must align with upper edge of cylinder head.

13-7

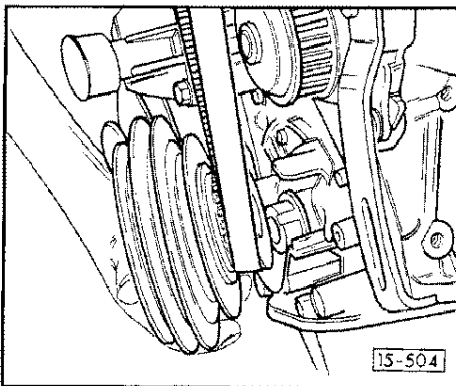

- ▶ - Fit toothed belt on crankshaft toothed belt sprocket and secure vibration damper to crankshaft - Fig. 1, page 13-5.

Caution
When securing vibration damper, the toothed belt must not become trapped between the oil pump and toothed belt sprocket.

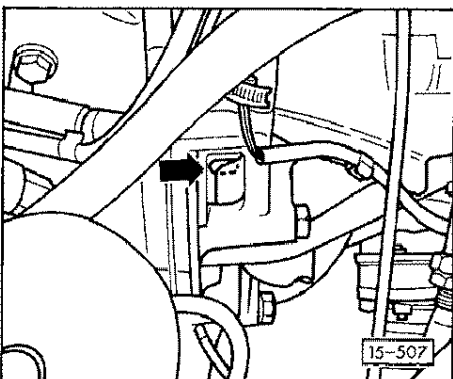
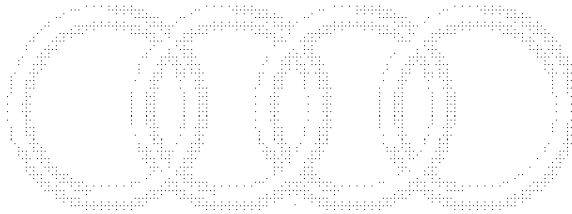

- ▶ - Set crankshaft to TDC.

With engine in situ:

- Align TDC marking (0) with boss on clutch housing.

Protected by copyright. Copying for private or commercial purposes in part or in whole is not permitted unless authorized by AUDI AG. AUDI AG does not guarantee or accept any liability with respect to the correctness of information in this document. Copyright by AUDI AG



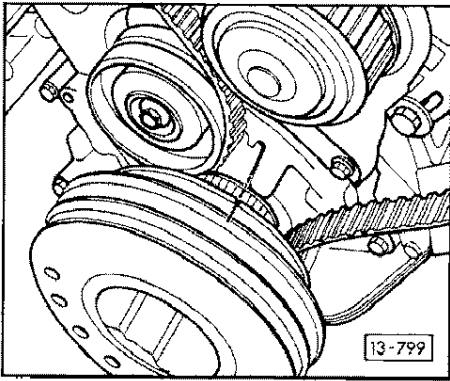

- With engine out:
- ▶ - Align notch on vibration damper with adjustment mark on oil pump housing.
 - Install lower toothed belt guard. (Additional adjustment mark provided.)
 - Fit toothed belt over idler pulley and coolant pump onto camshaft sprocket.

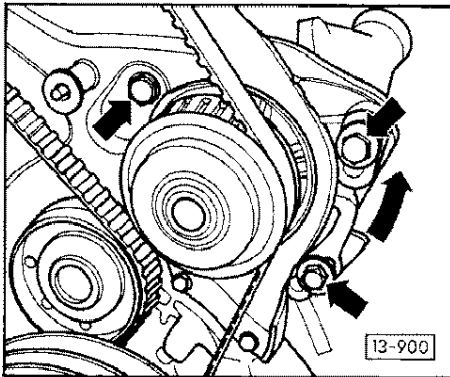

- ▶ - Tension toothed belt by turning loosened coolant pump anti-clockwise (upwards).

13-9

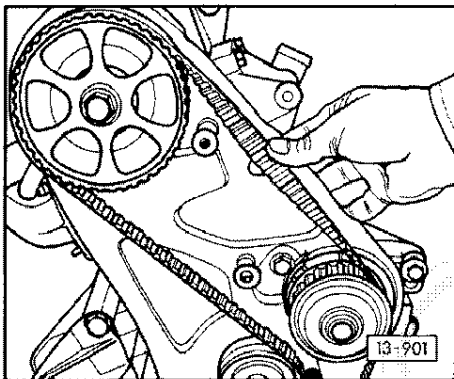

- ▶ - It should just be possible to turn the toothed belt 90° with thumb and forefinger between camshaft sprocket and coolant pump.
- Tighten coolant pump to 20 Nm.
- Turn crankshaft two full turns and check adjustment.
- Check basic setting of distributor - Repair Group 28
- Install pump for central hydraulic system and tension V-belt - page 13-12.

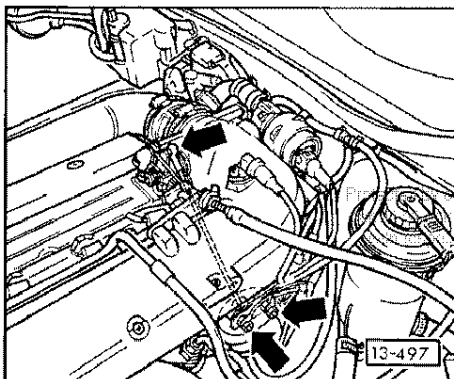

- ▶ Removing CCS cruise control vacuum unit
- Remove ball pin securing clip.
- Disconnect linkage from cam ball pin.
- Unscrew vacuum unit bracket.

Copyright. Copying for private or commercial purposes, in part or in whole, is not authorized by AUDI AG. AUDI AG does not guarantee or accept any liability for the correctness of information in this document. Copyright by AUDI AG



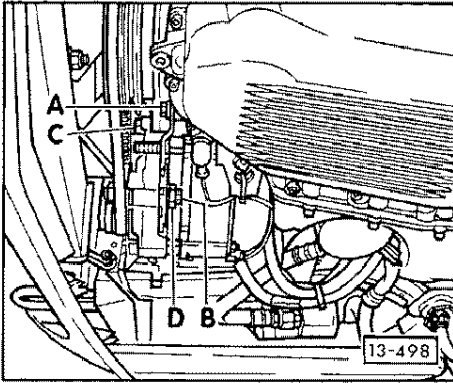

TENSIONING ALTERNATOR V-BELT

- Remove screws securing radiator cowl at top.
- ◀ - Slacken off at least one turn securing bolts (A) and (B) for tensioner arm, and bolt (C) for alternator.

Note:

The alternator must move easily after the mounting bolts have been slackened.

- Tension V-belt by turning tensioner nut (D) with a torque wrench and tighten tensioner nut locking bolt (B) to 35 Nm

New V-belt	- 8 Nm
Used V-belt	- 4 Nm

- Check tension by deflecting belt with thumb.

New V-belt	- approx. 2 mm
Used V-belt	- approx. 5 mm

- Tighten alternator securing bolt -C- to 35 Nm, and tensioner arm -A- to 20 Nm.

13-11

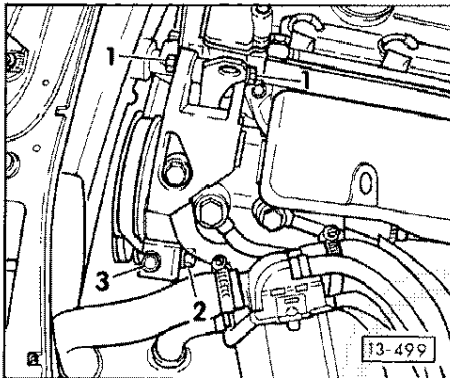

TENSIONING V-BELT FOR CENTRAL HYDRAULIC PUMP

Note:

The Torque wrench V.A.G 1410 in conjunction with socket V.A.G 1410/2, 22 mm is particularly suitable for this adjustment.

- ◀ - Slacken bolts (1).
- Slacken nut (2).
- Turn tensioner bolt (3) as appropriate.
- Check tension by deflecting belt with thumb.
- Deflection for both new and used V-belts: approx. 10 mm.
- Tighten securing bolts (1) and securing nut (2) to 22 Nm.

Protected by copyright. Copying for private or commercial purposes, in part or in whole, is not permitted unless authorised by AUDI AG. AUDI AG does not guarantee or accept any liability with respect to the correctness of information in this document. Copyright by AUDI AG



13-12

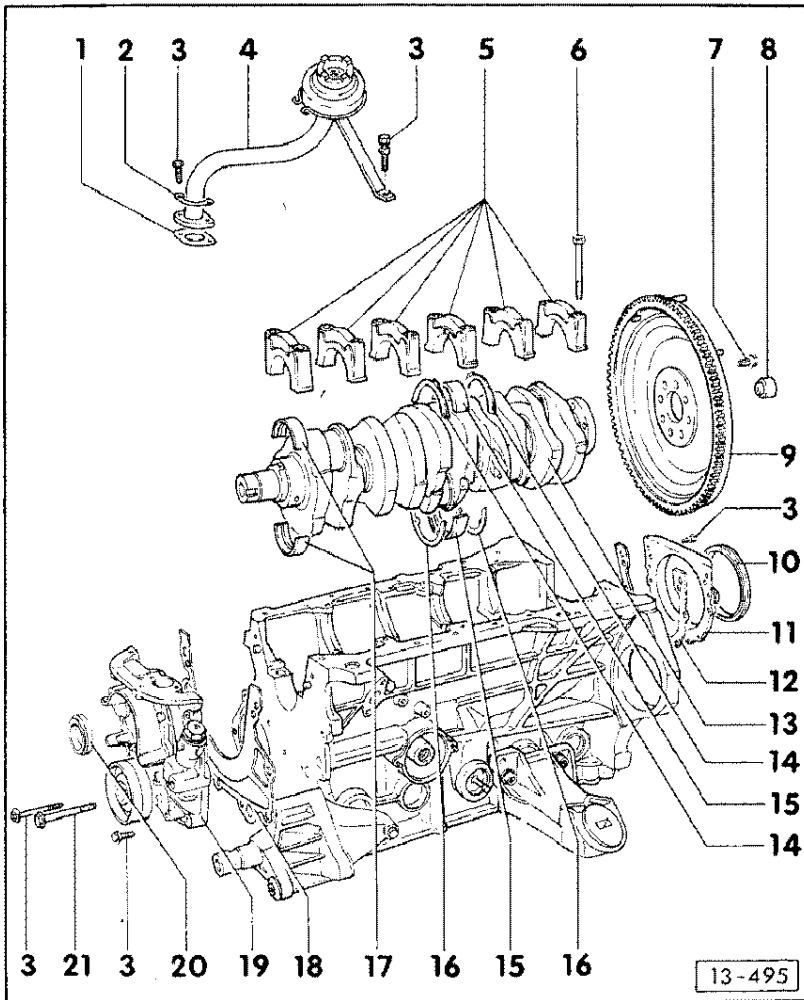

DISMANTLING AND ASSEMBLING CYLINDER
 =====
 BLOCK, CRANKSHAFT AND FLYWHEEL
 =====

Notes:

- Renew all gaskets, 'O' rings, and oil seals on shafts.
- Do not rotate crankshaft when checking radial clearance.

1- Suction pipe gasket

2- Locking plate
 • Replace

3- 10 Nm

4- Suction pipe
 • First secure to oil pump

5- Bearing cap
 • No. 1 cap at pulley end
 • Retaining lugs on bearing shells must align
 • Watch bore offset

6- 65 Nm

7- 100 Nm
 • Renew bolts
 • Fit bolts using locking compound -06-

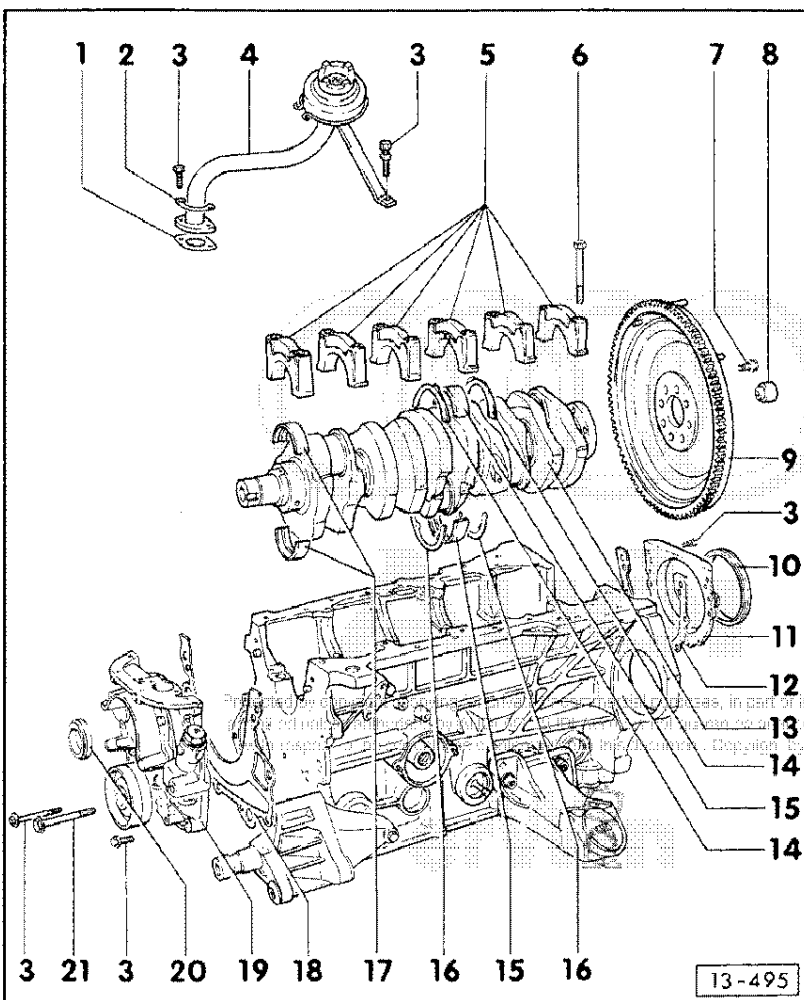

8- Needle bearing
 • Pulling out - see Fig. 1 page 13-17
 • Knocking in - see Fig. 2 page 13-17
 • After fitting the bearing the lettered side must be visible.

9- Flywheel
 • Remove and refit using locking spanner 10-201.
 • Fit ignition timing pin subsequently - see page 13-23 onward.

10- Oil seal
 • Press out using special tool 2086 - see Fig. 3 page 13-18
 • Lightly coat sealing lip and outer edge before fitting.
 • Offer up using 2003/2A.
 • Press home using 2003/1 - Fig. 4 page 13-18

11- Sealing flange, rear

12- Rear sealing flange gasket
 • Replace

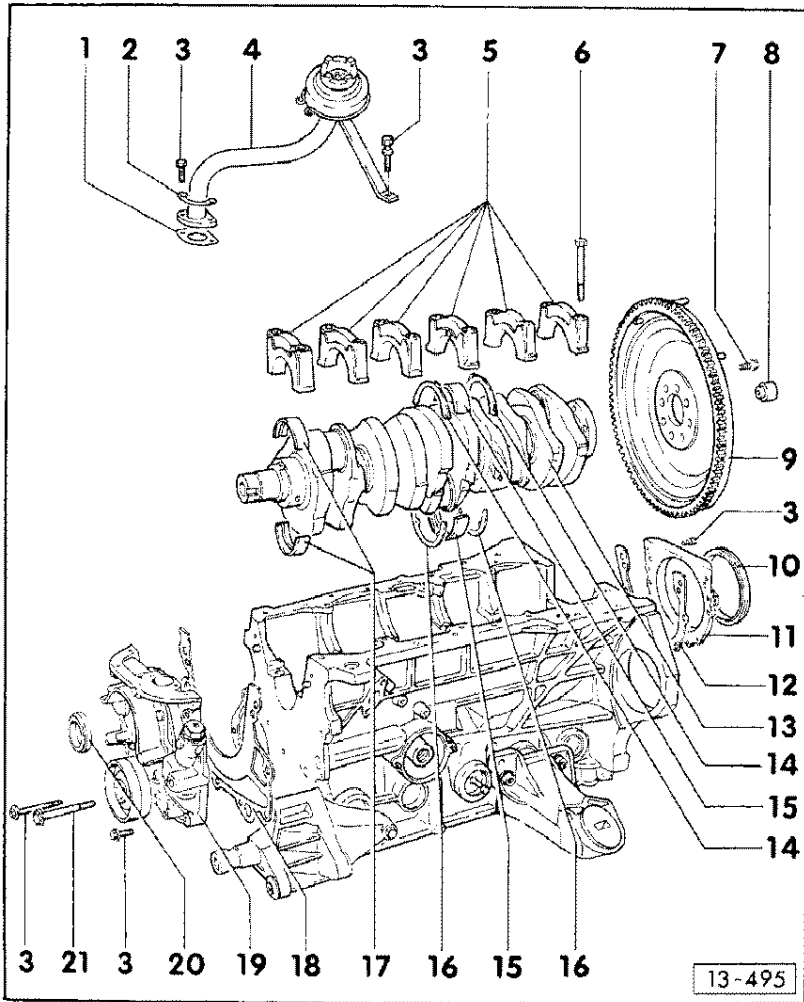

- 13- Crankshaft
- Measure axial clearance - Fig. 7 p. 13-20
New: 0.07 ... 0.23 mm
Wear limit: 0.30 mm
 - Measure radial clearance with Plastigage - page 13-21.
New: 0.018 ... 0.058 mm
Wear limit: 0.16 mm.
 - Crankshaft dimensions - page 13-22

- 14- Thrust washer
- For cap
 - Watch method of securing

- 15- Bearing shell 4
- Complete with thrust washers
 - For cap without oil groove
 - For cylinder block with oil groove

- 16- Thrust washer
- For cylinder block (without retaining lug)

- 17- Bearing shells 1, 2, 3, 5 and 6
- For cap without oil groove
 - For cylinder block with oil groove
 - Do not interchange worn bearing shells
 - Retaining lug must engage recess in crankcase/bearing cap

- 18- Oil pump gasket

13-15

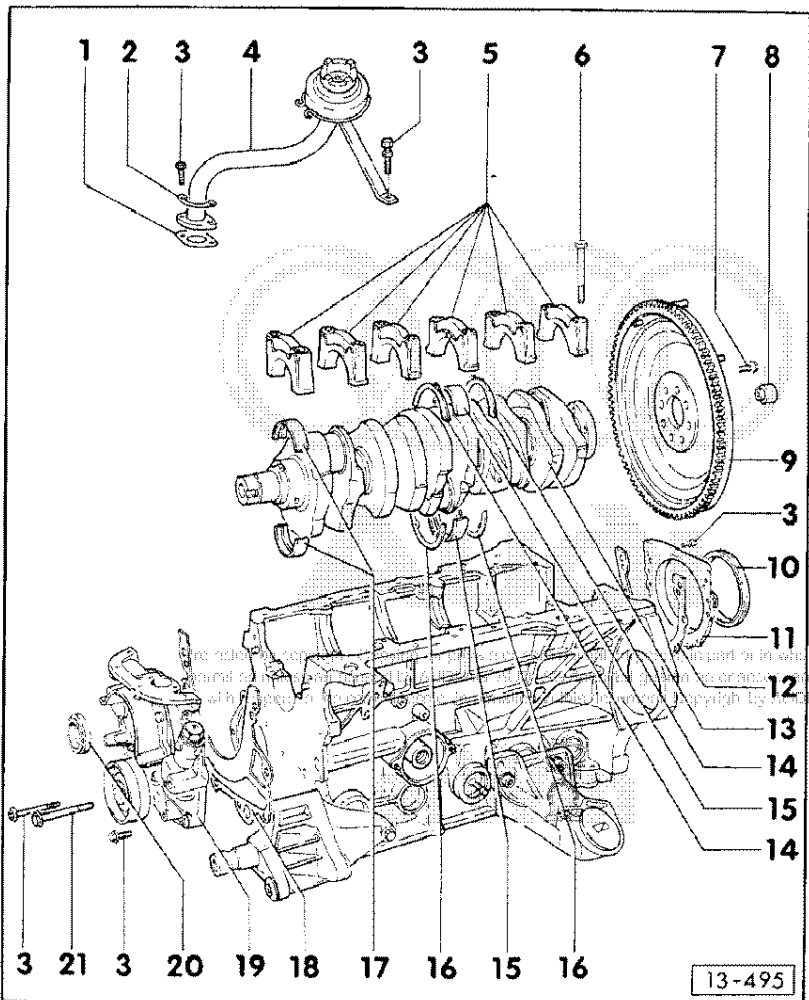

- 19- Oil pump
- Watch crankshaft drive dog when installing pump.

- 20- Oil seal
- Remove using 2086 - Fig. 5 page 13-19
 - Lightly coat sealing lip and outer edge with oil before fitting.
 - Offer up using 2080 A - Fig. 6 page 13-19
 - Press home using thrust sleeve (part of 2080 A) - Fig. 6 page 13-19.

- 21- 22 Nm

13-16

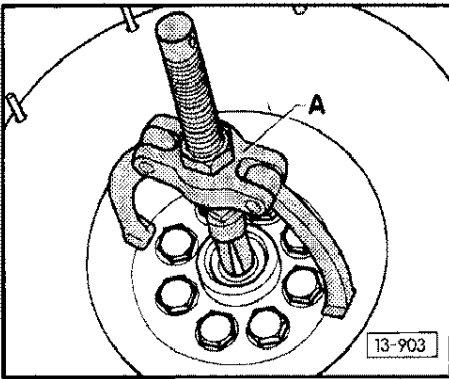

◀ Fig. 1 Withdrawing needle bearing

- Remove using bearing extractor and holding tool (A), e.g. Kukko 21/2 = 14.5 ... 18.5 mm and Kukko 22-1.

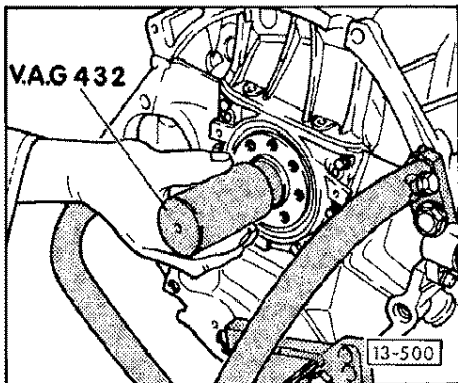

◀ Fig. 2 Knocking-in needle bearing

After installation the lettered side must be clearly visible.

- Knock bearing home until flush using VW 432.

13-17

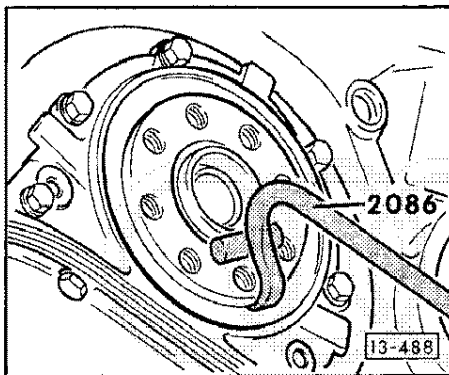

◀ Fig. 3 Removing crankshaft oil seal, flywheel end

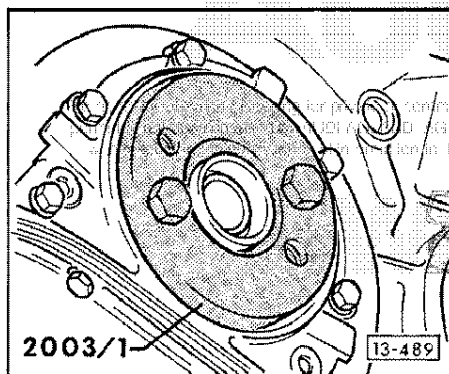

◀ Fig. 4 Pressing-in crankshaft oil seal, flywheel end.

- Lightly coat sealing lip and outer edge of seal with oil before installing.
- Offer up oil seal using sleeve 2003/2A.
- Press home oil seal using special tool 2003/1.

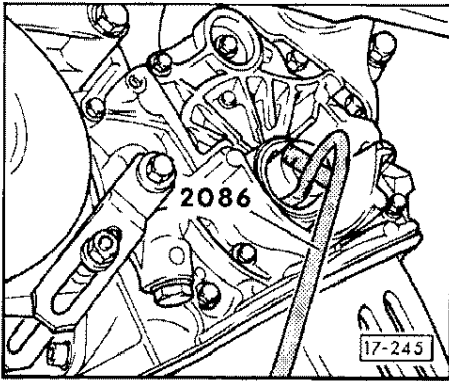

◀ Fig. 5 Removing crankshaft oil seal, pulley end

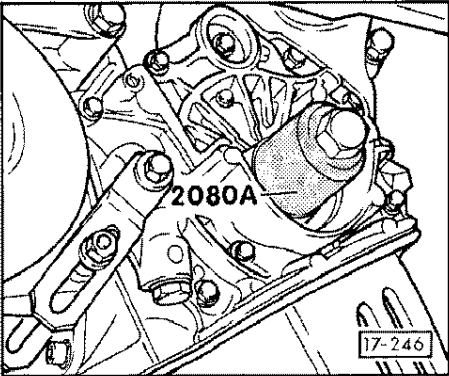

◀ Fig. 6 Pressing-in crankshaft oil seal until flush, pulley end

- Use vibration damper mounting bolt.
- Lightly coat sealing lip and outer edge of seal with oil before pressing in.

Caution
Press seal fully home if crankshaft shows signs of scoring.

- Offer up using locating sleeve from 2080 A.
- Press in using thrust sleeve from 2080 A.

13-19

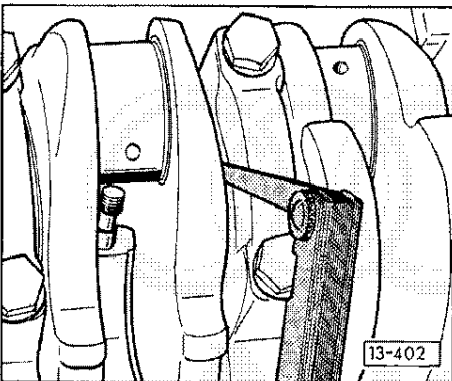

◀ Fig. 7 Crankshaft - measuring axial clearance

Measure axial clearance at no. 4 bearing (thrust bearing).

New: 0.07 ... 0.23 mm
Wear limit: 0.30 mm

Printed by copyright. Copying for private or commercial purposes in part or in whole is not permitted unless authorized by AUD AG. AUD AG does not guarantee or accept any liability with respect to the correctness of information in this document. Copyright by AUD AG



CHECKING RADIAL CLEARANCE OF CRANKSHAFT

=====

Note:

Radial clearance can be checked with Plastigage, even with engine in situ.

Measuring range of Plastigage strip:

	Colour	Type
0.025 ... 0.076 mm	Green	PG-1
0.050 ... 0.150 mm	Red	PR-1
0.100 ... 0.230 mm	Blue	PB-1

- Take bearing cap off.
- Clean bearing shell and crankshaft journal.
- ▶ - Place Plastigage strip on journal or bearing shell in an axial direction.
- Install cap and shell and tighten to 65 Nm.

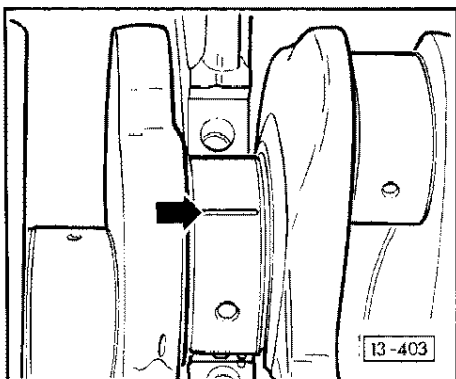

Caution
Do not rotate crankshaft.

- Take bearing cap off again.

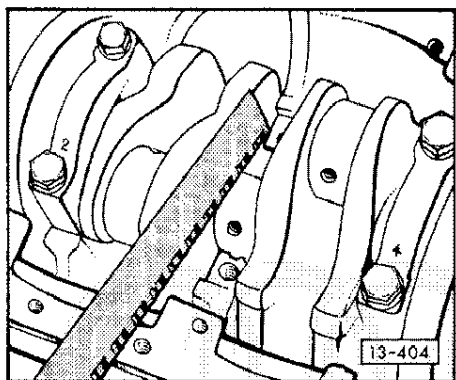

- ▶ - Compare width of strip with measuring scale.

New: 0.018 ... 0.058 mm
Wear limit: 0.16 mm.

13-21

CRANKSHAFT DIMENSIONS

=====

(mm)

Honing dimension	Main bearing Journal \varnothing	Crank pin \varnothing
Basic dimension	-0.022	-0.022
	58.00	47.80
1st undersize	-0.022	-0.022
	57.75	47.55
2nd undersize	-0.022	-0.022
	57.50	47.30
3rd undersize	-0.022	-0.022
	57.25	47.05
	-0.042	-0.042

Protected by copyright. Copying for private or commercial purposes in print or in digital form is not permitted unless authorised by AUDI AG. AUDI AG does not guarantee or accept any liability with respect to the correctness of information in this document. Copyright by AUDI AG.

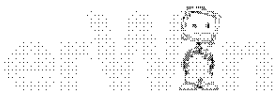

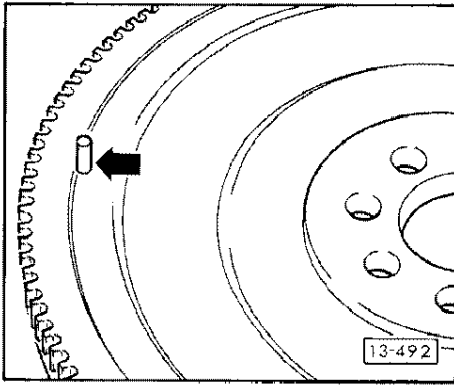

◀ Inserting pin for ignition timing point

Do not bend pin when fitting a new flywheel.

Caution

Install pin for ignition timing point when fitting a new flywheel otherwise the electronic ignition system will not receive control pulses and the engine cannot start.

Drive ignition timing point pin into flywheel so that it is flush.

Measure distance between pin and firing point sender (G 4)
and distance between flywheel and engine speed sender (G 28)

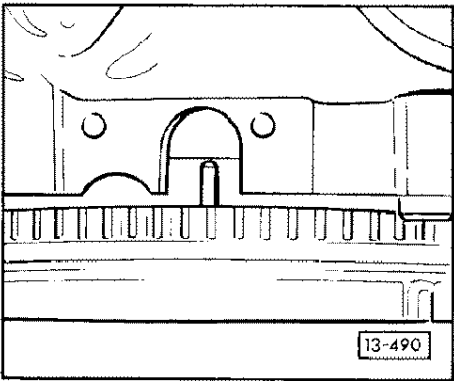

◀ - Rotate flywheel until pin is below firing point sender aperture.

13-23

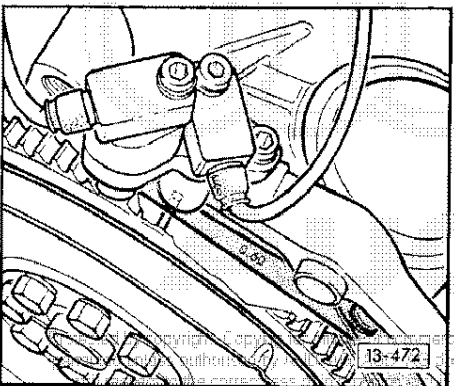

◀ - Screw in firing point sender.

- Insert feeler gauge between pin and firing point sender.

Specified gap: 0.45 - 1.25 mm

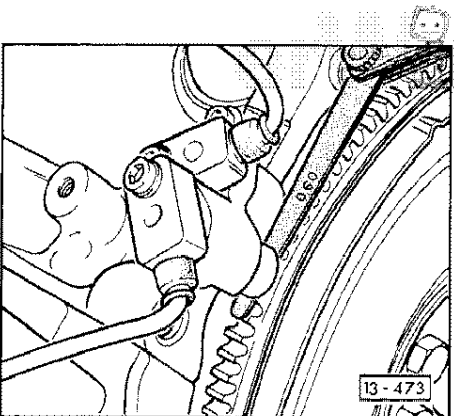

◀ - Insert feeler gauge between flywheel starter ring gear teeth and engine speed sender.

Specified gap: 0.50 - 1.25 mm

13-24

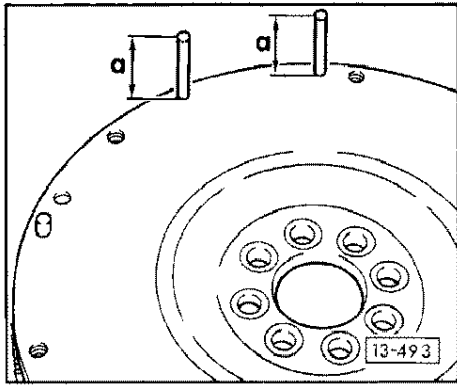

◀ Inserting pins for ignition angle

Do not bend pins when fitting a new flywheel.

Height of pins: 36 - 0.5 mm (Dim. "a")

13-25

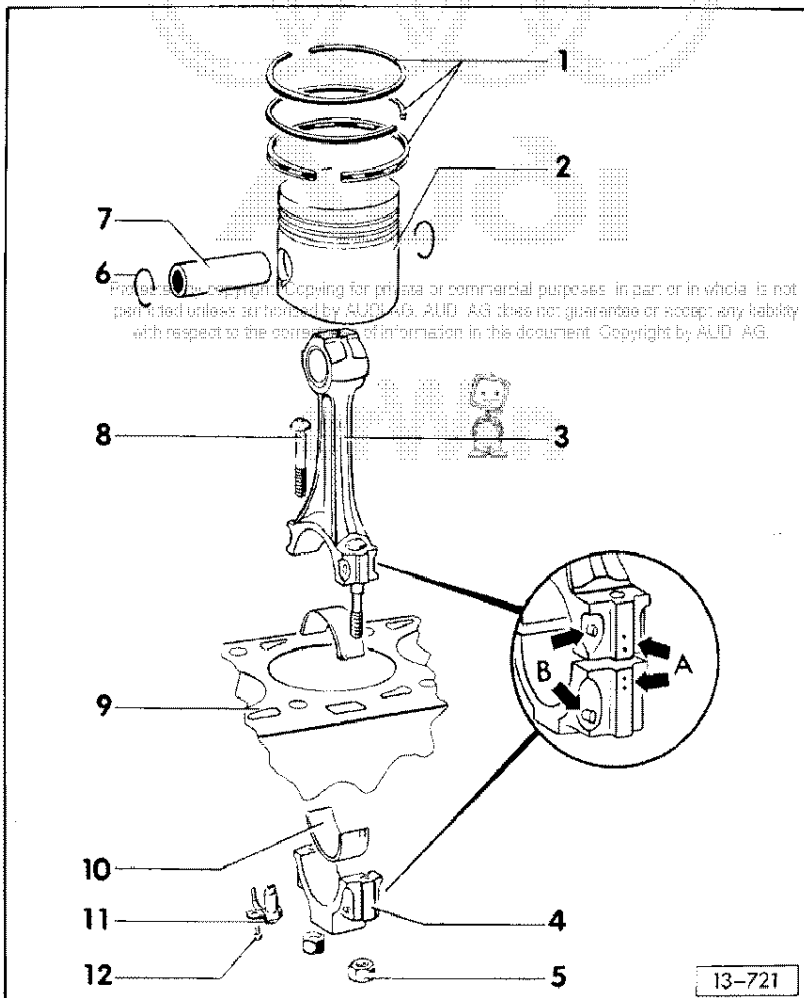

DISMANTLING AND ASSEMBLING PISTONS
AND CONRODS:
=====

1- Piston rings

- Offset gaps to 120°
- "TOP" points towards piston crown - Fig. 1
- Removing and installing with piston ring pliers - Fig. 2
- Checking clearance in groove - Fig. 3
- Checking ring gap - Fig. 4

2- Piston

- Checking - Fig. 6
- Mark installation position and cylinder number - Fig. 7
- Install using piston ring clamp - Fig. 8
- Arrow on piston crown points to pulley end
- Piston dimensions - page 13-31

3- Conrod

- Always renew as a set
- Mark cylinder number (A)
- Installation position: Markings (B) point towards pulley end

13-721

13-26

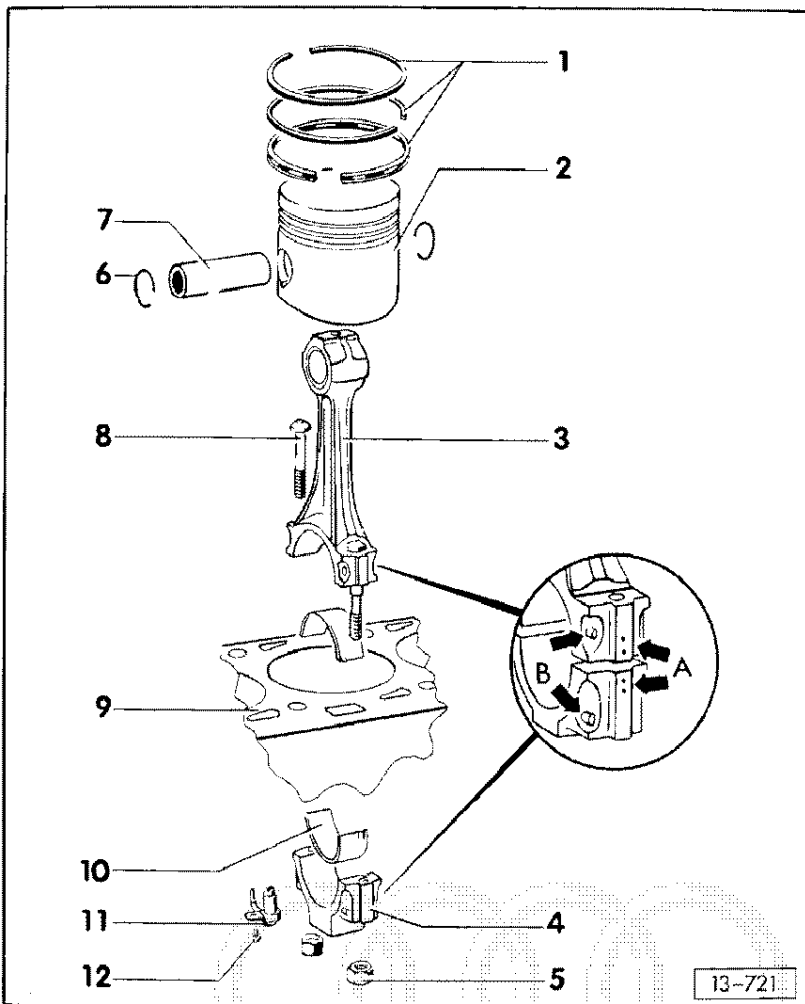

- 4- Conrod bearing cap
 - Mark cylinder number (A)
 - Installation position: Markings (B) point towards pulley end
- 5- 30 Nm + 1/4 turn (90°)
 - Oil contact surface
 - For measuring radial clearance, tighten to 30 Nm but no further.
- 6- Circlip
 - Lever out - Fig. 5
- 7- Piston pin
 - If difficult to remove, heat piston to approx. 60° C
 - Use special tool 10-508 for removing and installing
- 8- Conrod bolt
- 9- Cylinder block
 - Checking cylinder boras - Fig. 9
 - Piston and cylinder dimensions - page 13-31

13-27

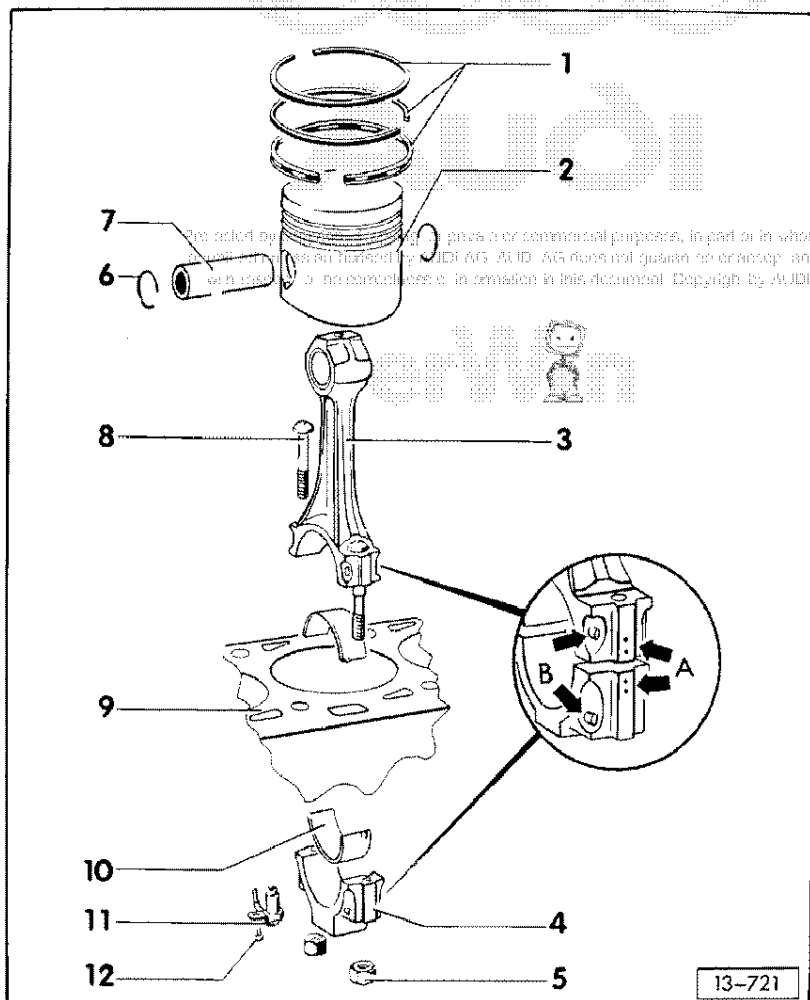

- 10- Bearing shell
 - Note installation position
 - Do not interchange used bearing shells
 - Ensure that retaining lugs locate in recesses in bearing caps and conrod.
 - Measuring axial clearance - Fig. 10
 - Wear limit: 0.4 mm
 - Checking radial clearance with Plastigage - page 13-35
 - New: 0.010 - 0.052 mm
 - Wear limit: 0.12 mm

Note:
Do not rotate crankshaft when checking radial clearance.

- 11- Oil spray jet
 - For cooling piston

- 12- 10 Nm

13-28

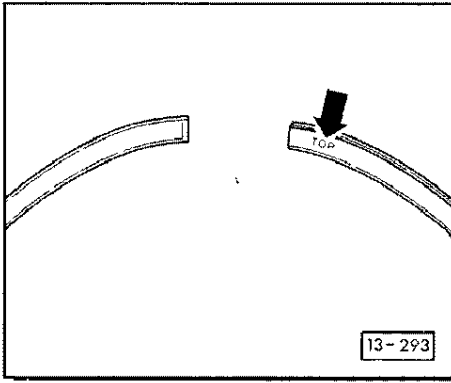

◀ Fig. 1 Pistons rings, installation position

- "TOP" must face towards piston crown.
- Chamfer on plain ring must face towards piston crown.
- Step on stepped ring must face towards piston pin.

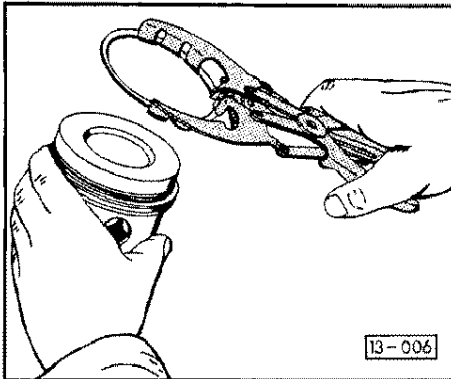

◀ Fig. 2 Removing and installing piston rings



13-29

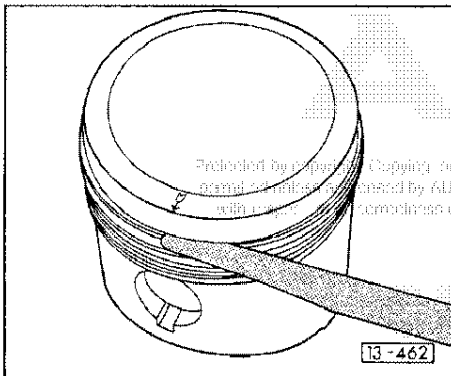

◀ Fig. 3 Checking piston ring clearance in groove

New: 0.04 ... 0.072 mm
Wear limit: 0.1 mm

Protected by copyright. Copying, reproduction or commercial purposes, in part or in whole, is not permitted without the prior written consent of AUDI AG. AUDI AG does not guarantee or accept any liability with respect to the completeness of information in this document. Copyright by AUDI AG

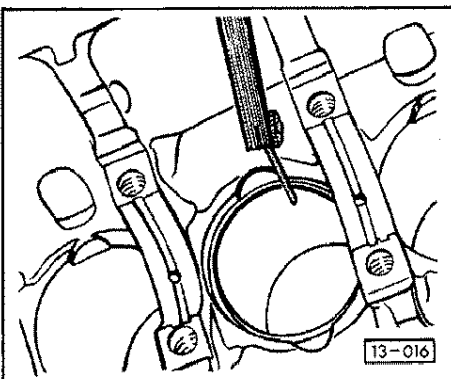

◀ Fig. 4 Checking piston ring gap

Push ring squarely into lower end of cylinder until it is about 15 mm from bottom edge.

New: 0.15 ... 0.35 mm
Wear limit: 1.0 mm

Piston dimensions

Honing dimension	Piston dia.	Cyl. bore
Basic dimension	80.98	81.01
1st oversize	81.23	81.26
2nd oversize	81.48	81.51

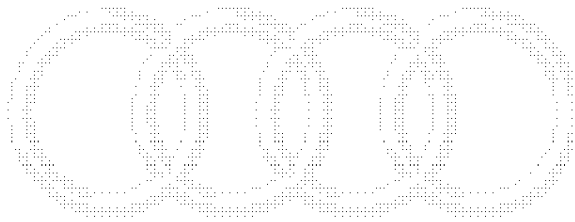

13-31

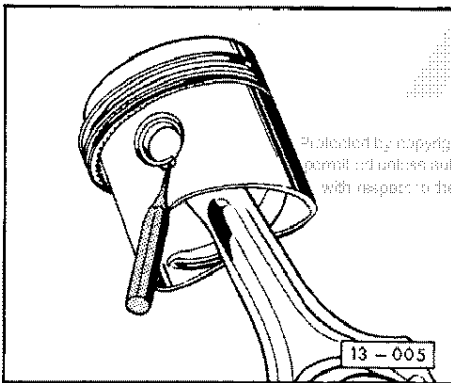

◀ Fig. 5 Lever out circlip

Protected by copyright. Copying or reuse for non-commercial purposes, in part or in whole, is not permitted unless authorized by AUDI AG. AUDI AG does not guarantee as to the complete reliability with respect to the correctness of information in this document. Copyright by AUDI AG

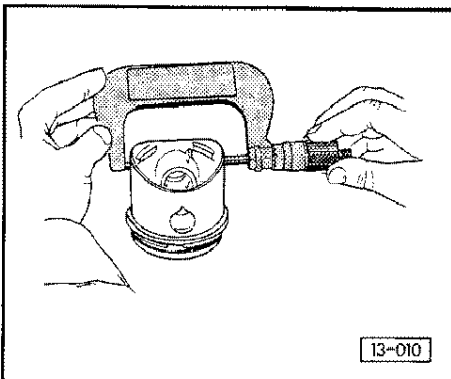

◀ Fig. 6 Checking piston

Measure piston about 12 mm from bottom of skirt at 90° to piston pin axis.

Maximum deviation from nominal dimension: 0.04 mm.

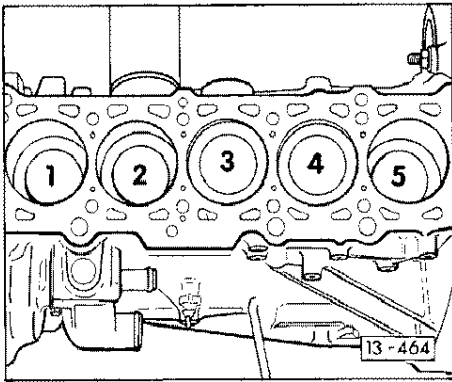

← Fig. 7 Marking piston installation position

Arrow on piston crown points towards the pulley end. Mark with cylinder number.

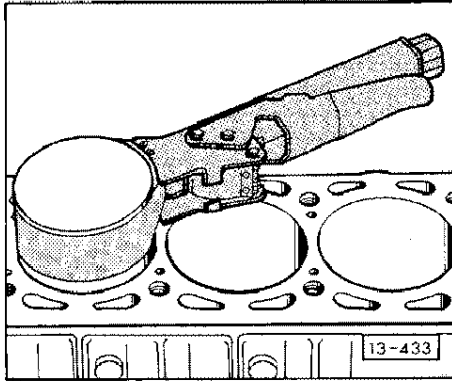

← Fig. 8 Removing and installing piston

- Use piston ring clamp to install.

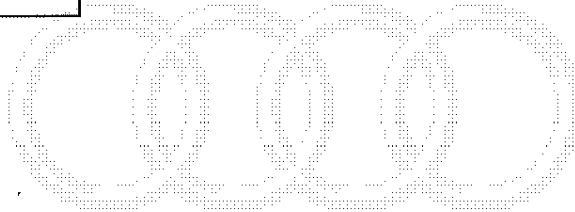

13-33

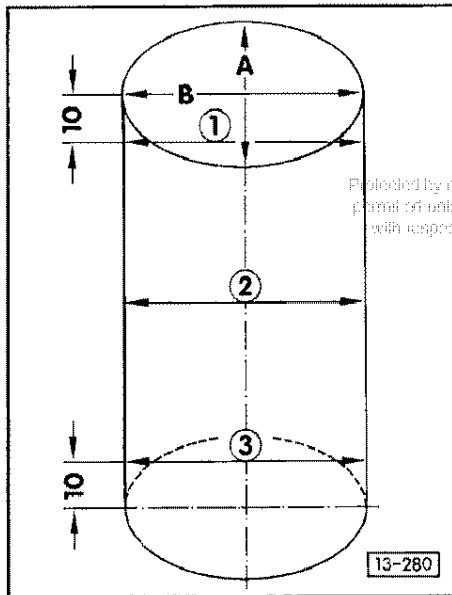

← Fig. 9 Checking cylinder bores

Measure bores at three locations in both directions, i. e. (A) across the engine and (B) in line with the crankshaft.

Use internal dial gauge 50 - 100 mm.

Maximum deviation from nominal dimension: max. 0.08 mm.
Protected by copyright. Copying or reuse in any manner whatsoever without the consent of the copyright owner is prohibited. Copyright by AUDI AG.
 (Piston and cylinder dimensions - page 13-31).

Note:

Measuring the cylinder bores must not be done when the cylinder block is mounted on a repair stand with adapter VW 540, as incorrect measurements would then be possible.

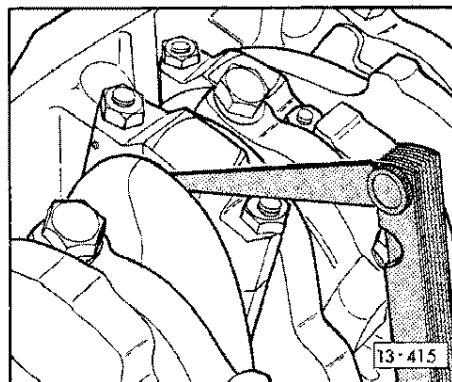

← Fig. 10 Measuring conrod axial clearance

Wear limit: 0.4 mm

13-34

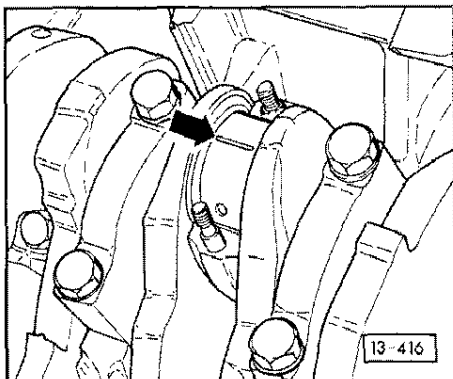

CHECKING CONROD RADIAL CLEARANCE

=====

Note:

It is possible to check radial clearance with Plastigage, even with engine in situ.

◀ Measuring range of Plastigage strip:

	Colour	Type
0.025 - 0.076 mm	Green	PG-1
0.050 - 0.150 mm	Red	PR-1
0.100 - 0.230 mm	Blue	PB-1

- Remove big end bearing cap.

- Clean shell and crank pin.

- Place Plastigage strip corresponding to width of crank pin on crank pin in axial direction or in bearing shell.
To measure radial clearance, install big end cap and tighten to 30 Nm but no further.

Caution

Do not rotate crankshaft.

- Take big end cap off again.

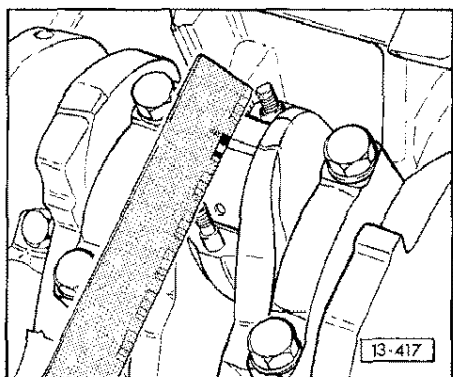

◀ - Compare width of strip with measuring scale.

New: 0.010 - 0.052 mm
Wear limit: 0.12 mm



13-35

Audi

Protected by copyright. Copying for private or commercial purposes in part or in whole is not permitted unless authorized by AUDI AG. AUDI AG does not guarantee or accept any liability with respect to the content, news or information in this document. Copyright by AUDI AG



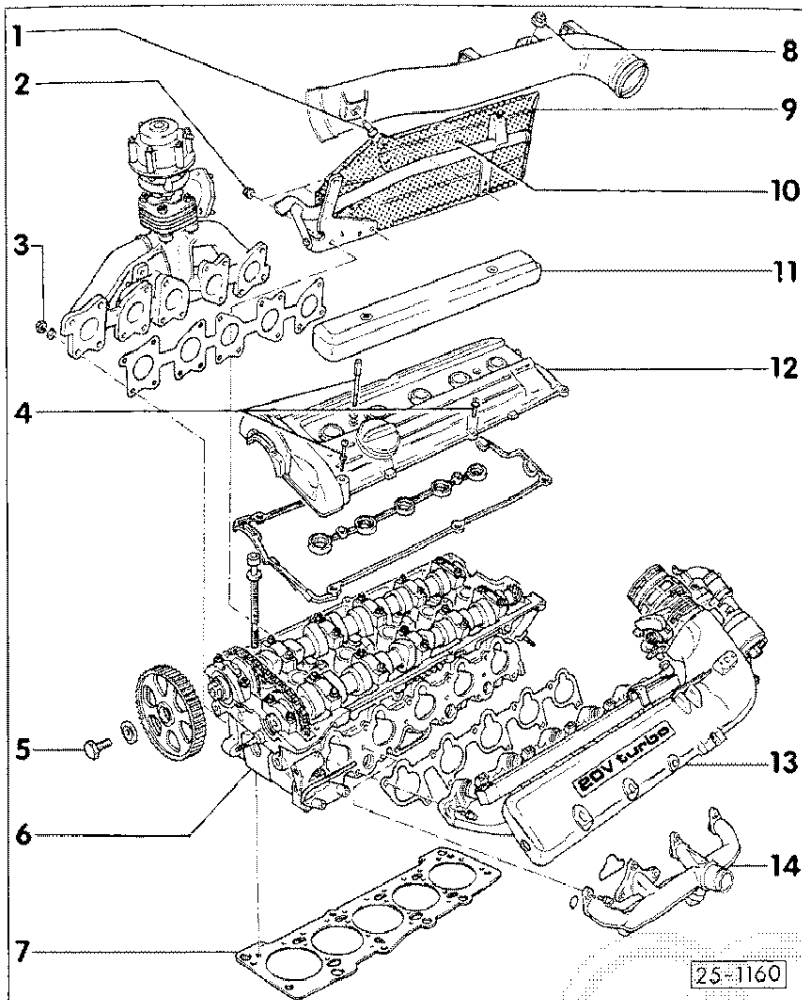

REMOVING AND INSTALLING CYLINDER HEAD
=====

Notes:

- Removing and installing injectors - see Repair Group 24
- Installing toothed belt - see Repair Group 13.
- The cylinder head can be removed with the engine in situ.
- Always renew all seals and gaskets when performing assembly work.
- When installing a replacement cylinder head, oil the contact surfaces between the bucket tappets and cam surfaces.

Caution
When new tappets have been installed, the engine must not be started for about 30 minutes (valves will strike pistons).

- Checking compression - page 15-6

- 1- 22 Nm
- 2- 22 Nm
- 3- 25 Nm

25-1160

15-1

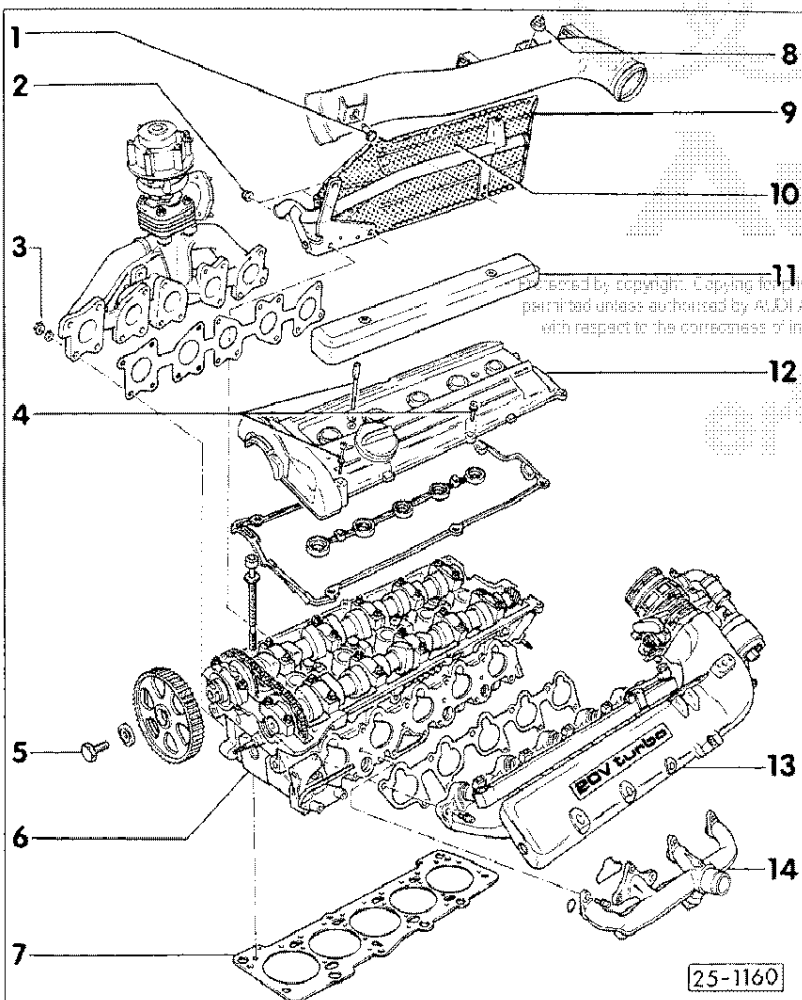

- 4- 10 Nm

- 5- 67 Nm

- 6- Cylinder head
 - Checking cylinder head for distortion - Fig. 1
 - Removing and installing cylinder head, page 15-4

- 7- Cylinder head gasket
 - Replace gasket.
 - Observe correct mounting position.
 - The marking "OBEN" or the part number must face the cylinder head.
 - Fit gasket over locating pins in cylinder block.

- 8- 22 Nm

- 9- Heat shield

- 10- Crankcase breather pipe

- 11- Ignition cable cover

- 12- Cylinder head cover
 - Remove throttle valve housing before removing cylinder head cover.

25-1160

15-2

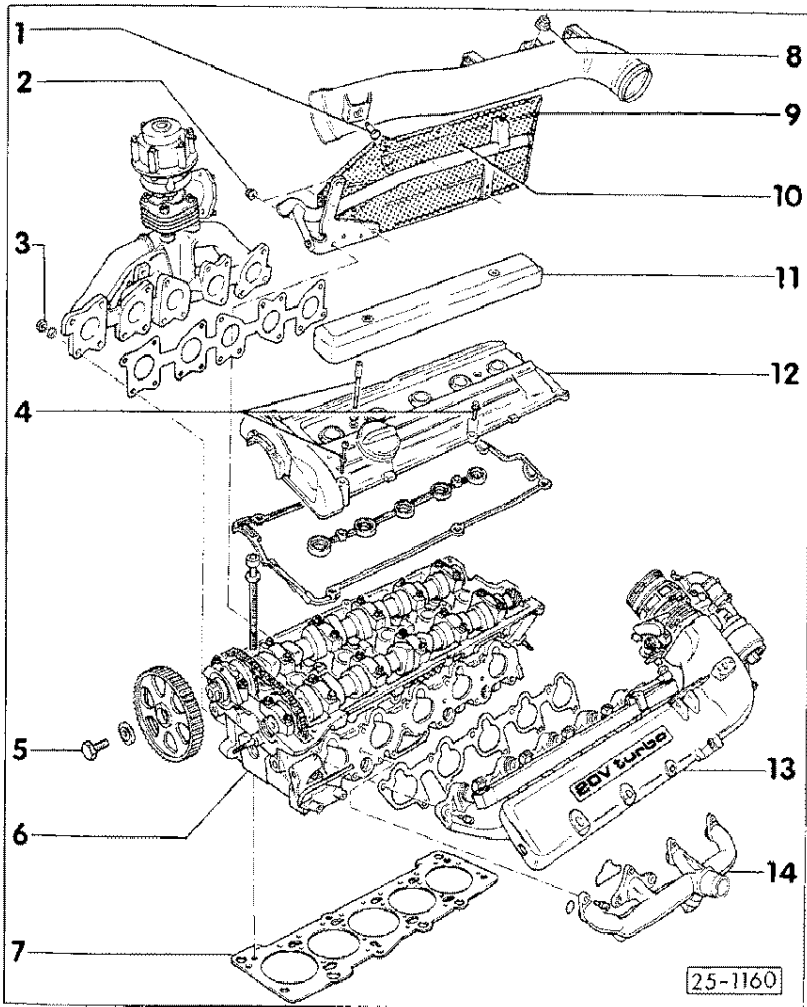

13- Induction manifold

- Tighten securing bolts to 22 Nm.
- Use hexagonal key V.A.G. 1669 for removal and installation of induction manifold.
- Vehicles equipped with CCS cruise control. Remove CCS vacuum unit before removing the induction manifold - page 13-10.

14- Coolant manifold

- Tighten securing bolts to 10 Nm.

15-3

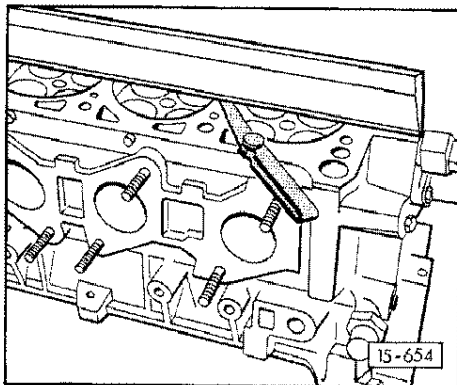

REMOVING AND INSTALLING CYLINDER HEAD

Note:

Before fitting cylinder head, ensure that crankshaft and cylinder head are set to TDC.

- Fit cylinder head gasket on to centering pins. The word "OBEN" or the Part.No. must face the cylinder head (watch pattern of holes).
- Install cylinder head, fit cylinder head bolts and tighten by hand.

Protected by copyright. Copying for private or commercial purposes, in part or in whole, is not permitted unless authorized by AUDI AG. AUDI AG does not guarantee or accept any liability with respect to the correctness of information in this document. Copyright by AUDI AG.

◀ Fig. 1 Checking cylinder head for distortion

Max. permissible distortion: 0.1 mm

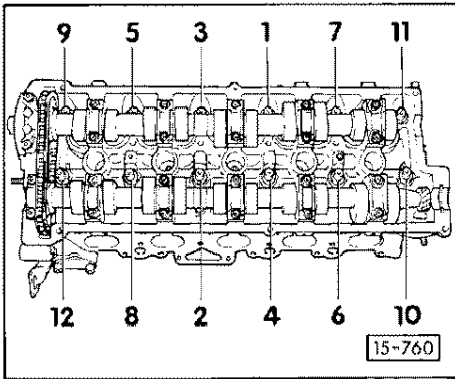

▲ - Tighten cylinder head bolts in three stages.
sequence - see diagram.

Tightening torque: Engine cold

Stage I = 40 Nm

Stage II = 60 Nm

Stage III = 1/2 turn (180°)

further, with normal spanner, without stopping.
(2 x 90° is also permissible).

Notes:

- Slacking cylinder head bolts: reverse sequence.
- It is not necessary to retighten the cylinder head bolts during the Inspection Service or after repairs.

15-5

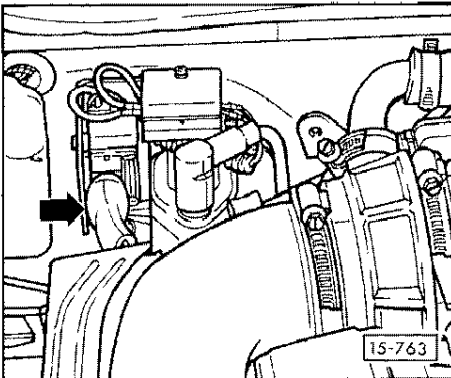

CHECKING COMPRESSION PRESSURES

- Minimum engine oil temperature: 30° C
- Throttle valve fully open
- Unplug connector (arrow) from ignition coil power stage
- Unscrew spark plugs using 3122

- Check compression pressures with V.A.G. 1381 and adapter 1381/5.

Note:

See operating instructions when using compression tester.

- Operate starter until tester shows no further pressure increase.

Copyright: Copying for private or commercial purposes, in part or in whole, is not permitted unless authorized by AUDI AG. AUDI AG does not guarantee or accept any liability for the correctness of information in this document. Copyright: by AUDI AG.

Compression pressures in bar	
New	Wear Limit
9 - 13	7



Overall permissible difference between cylinders: 3 bar.

15-6

SERVICING VALVE GEAR

=====

Note:

Cylinder heads which have cracks between the valve seat inserts and the spark plug threads can be used further without reducing service life, provided the cracks do not exceed a maximum of 0.5 mm in width or when no more than the first spark plug thread is cracked.

1- Bearing cap

- Installation position - Fig. 1 and Fig. 2
- Installation sequence - see "Installing camshafts" - page 15-20

2- 15 Nm

3- Oil seal

- Renew
- Oil sealing lip and outer edge of oil seal
- Removing and installing - page 15-17

4- Drive chain

5- Outer valve spring

- Remove and install with 2037 or fitting tool 2036, valve lever VW 541/1 and adapter VW 541/5

6- Inner valve spring

- Remove and install with 2037 or fitting tool 2036, valve lever VW 541/1 and adapter VW 541/5

7- Lower valve spring seat

- Remove and install with 3047 A

8- Valve stem seal

- Renewing: - page 15-25
- With cylinder head removed - page 15-27

9- Valve guide

- checking wear and renewing - page 15-22
- When carrying out repairs, use valve guide with shoulder
- Use support 3123

10- Cylinder head

- Reworking valve seats in page 15-13
- Checking distortion in page 15-4
- Reworking dimension for cylinder head:
Minimum dimension (118,1 mm) is measured through a cylinder head bolt hole.

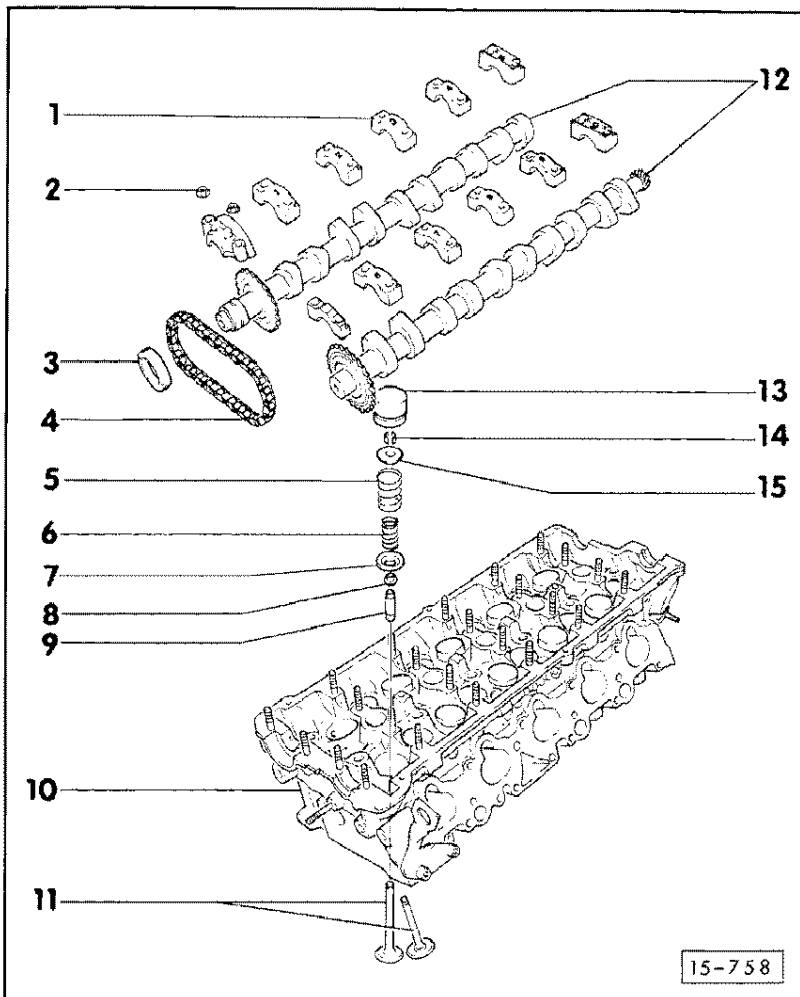

15-7

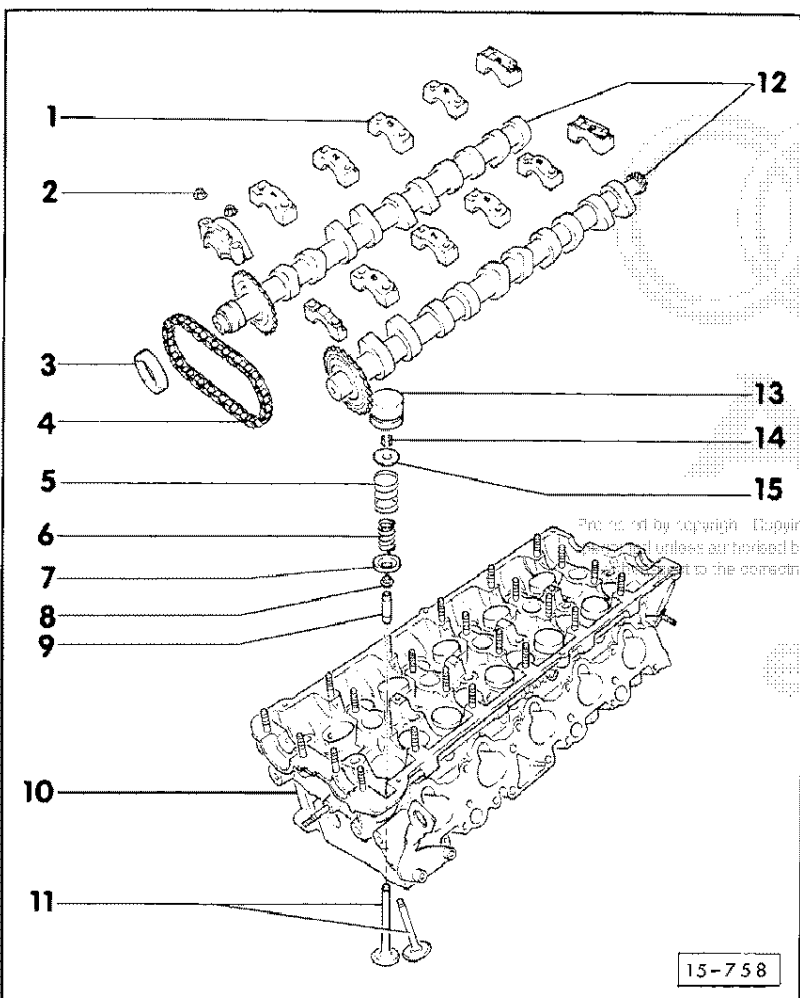

15-8

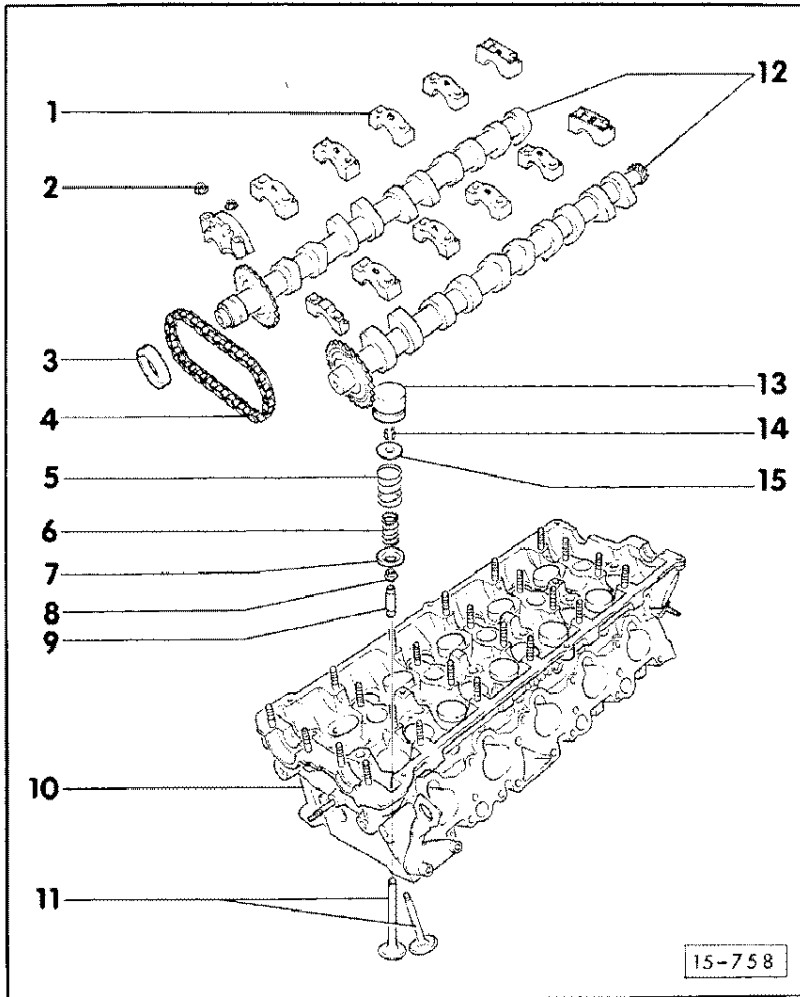

11- Valves

- Only grind in, do not rework
- Valve dimensions - Fig. 4
- Sodium-filled exhaust valves, see note on page 15-12

12- Camshafts

- Checking axial clearance - Fig. 3
- Removing and installing - Page 15-19
- Check radial clearance with Plastigage
Wear limit: 0.2 mm
- Max. runout 0.04 mm with bearing cap in front of chain and last bearing cap fitted.

13- Bucket tappets

- With hydraulic valve clearance compensation
- When removing, mark cylinder number
- Checking - page 15-15
- When removing, place tappet with cam contact surface facing downwards
- Before installation, check axial clearance of camshafts - Fig. 3
- Oil contact surface

14- Valve cotter pins

- Removing - page 15-26

15- Upper valve spring seat

15-9

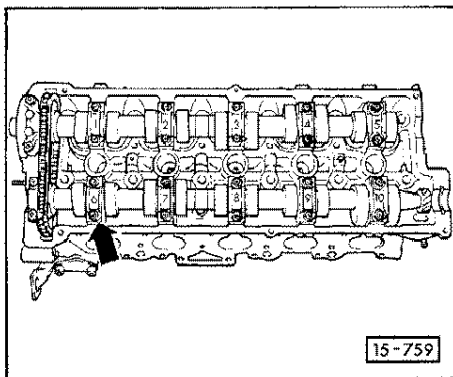

← Fig. 1 Installation position of camshaft bearing cap

The recesses (corners) on the bearing caps must point towards the intake side of the cylinder head (arrow).

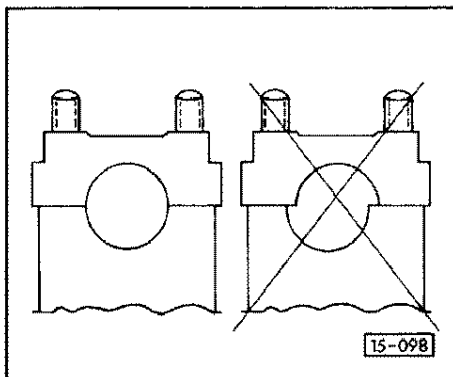

← Fig. 2

Watch offset. Before installing camshaft, fit bearing cap and determine installation position.

Preparation by copyright. Copying for private or commercial purposes in part or in whole, is not permitted unless authorized by AUDI AG. AUDI AG does not guarantee or accept any liability with respect to the consequences of its application. Copyright by AUDI AG.



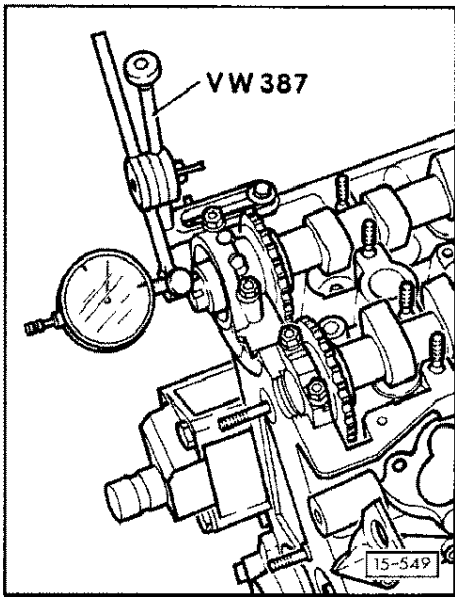

◀ Fig. 3 Checking camshaft axial play

Wear limit: 0.2 mm

Take reading with bucket tappets removed, chain removed and first and last bearing caps fitted.

15-11

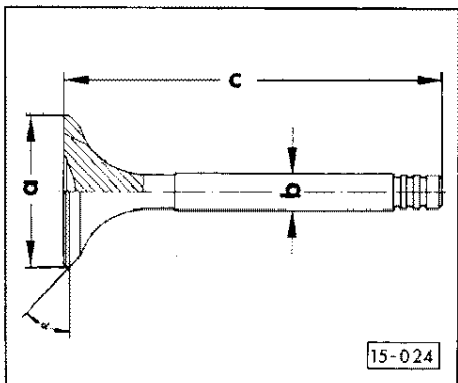

◀ Fig. 4 Valve dimensions

Inlet valve	Exhaust valve
a = dia. 32.00 mm	28.00 mm
a = dia. 6.97 mm	6.94 mm
c = 95.50 mm	98.20 mm
α = 45 deg.	45 deg.

Caution
Valves must not be reworked. They may only be ground in.

Notes:

Worn-out sodium-filled exhaust valves cannot just simply be scrapped. Using a hacksaw, the valves should be cut in two across the middle of the stem. During this operation they must not come into contact with water. Throw a maximum of 10 valves prepared in this way into a bucket of water and step back quickly to avoid any danger from the ensuing chemical reaction during which the sodium will burn. The parts treated in this way can then be disposed of like normal scrap.

Produced by www.vw.com
permitted under the terms of the Volkswagen Group's copyright liability with respect to the source of information in this document. Copyright by VWG AG



15-12

REWORKING VALVE SEATS

Note:

Only rework the valve seats enough to produce a perfect contact surface. Before reworking commences, calculate the maximum permissible reworking dimension. If this dimensions is exceeded, correct functioning of the hydraulic tappet can no longer be guaranteed and the cylinder head must be renewed.

Calculating maximum permissible reworking dimension(b)

- Insert valve and press it tightly against the valve seat

← - Measure the distance between the end of the valve stem centre and upper edge of cylinder head.

Measured dimension minus minimum dimension gives the maximum permissible reworking dimension.

Minimum dimension

Inlet valve = 36.0 mm
Exhaust valve = 36.3 mm

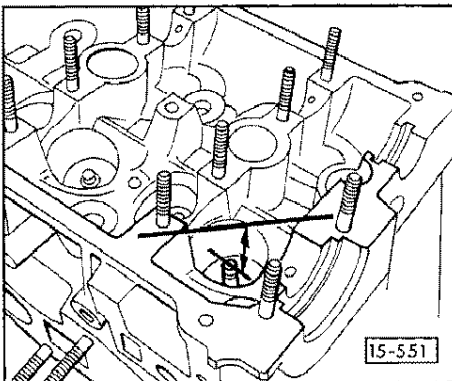

15-13

← Reworking inlet valve seat

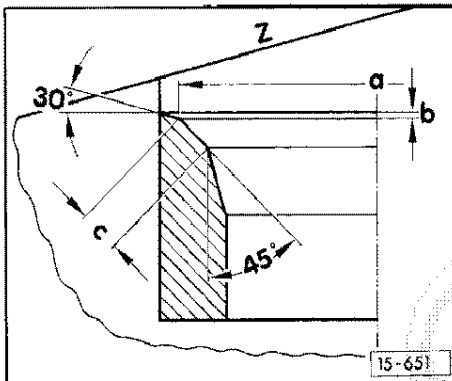

a = 31.2 mm \varnothing
b* = max. permissible reworking dimension
c = 1.5 ... 1.8 mm
(If necessary, rework valve seat with 75° reseating tool)
Z = Lower edge of cylinder head
30° = Upper correction angle
45° = Valve seat angle

← Reworking exhaust valve seat

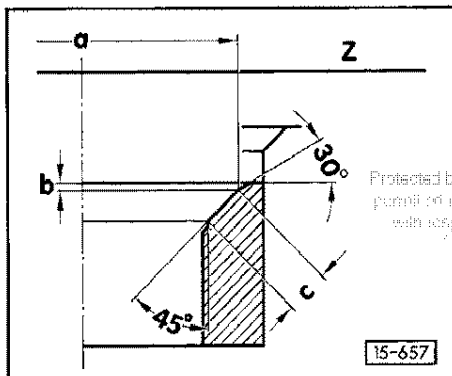

a = 27.6 mm \varnothing
b* = max. permissible reworking dimension
c = approx. 1.8 mm
Z = Lower edge of cylinder head
30° = Upper correction angle
45° = Valve seat angle*

Protected by copyright. Copying or preparation for commercial purposes, in part or in whole, is not permitted unless authorized by AUDI AG. AUDI AG does not guarantee or accept any liability with regard to the correctness of information in this document. Copyright by AUDI AG

* Max. permissible reworking dimension - page 15-13

15-14

CHECKING HYDRAULIC BUCKET TAPPETS

=====

Notes:

- Place removed tappet with the contact surface (cam side) facing downwards, on a clean surface.
- Renew tappets complete (cannot be adjusted or repaired).
- Irregular valve noises when starting engine are quite normal.

- Start engine and run it until radiator fan has switched on once.
- Increase engine speed to approx. 2500 rpm for 2 minutes. If the tappets are still noisy, locate defective tappet as follows:
- Remove cylinder head cover.
- Rotate crankshaft clockwise until cam of tappet to be checked is pointing upwards.

15-15

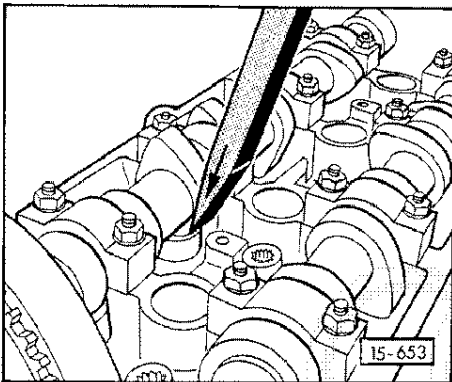

- ◀ - Press tappet down with a wooden or plastic wedge. If free travel in excess of 0.1 mm is felt before the valve opens, renew tappet.

Caution

When new tappets have been installed, the engine must not be started for about 30 minutes (valves will strike pistons).

Protected by copyright. Copying for private or commercial purposes, in part or in whole, is not permitted unless authorised by AUDI AG. AUDI AG does not guarantee or accept any liability with respect to the correctness of information in this document. Copyright by AUDI AG



15-16

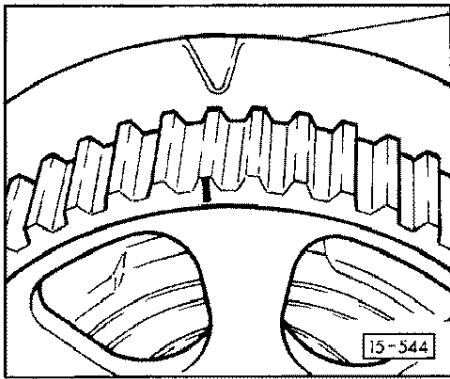

RENEWING CAMSHAFT OIL SEAL

Removing:

- Remove upper toothed belt guard.
- ◀ - Rotate crankshaft until No. 1 cylinder is at TDC.
- Release tension on toothed belt and remove.
- Remove camshaft sprocket.
- Screw camshaft sprocket securing bolt with washer into camshaft as far as it will go.
- Unscrew inner part of oil seal extractor 2085 two turns (approx. 3 mm) out of the outer part and lock in position with knurled screw.
- ◀ - Lubricate threaded head of oil seal extractor, place it in position and screw it into oil seal as far as possible while exerting pressure.

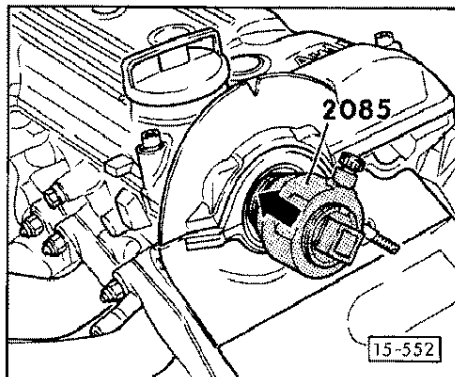

15-17

- Loosen knurled screw and turn inner part of extractor against camshaft until oil seal is extracted.
- Clamp extractor in vice on flats and remove oil seal with pliers.

Installing:

- Lightly oil sealing lip and outer edge of oil seal.
- Offer seal over locating sleeve 10-203.
- Press oil seal in as far as it will go using thrust sleeve 10-203 and offset screw 10-203/1.

Caution

Do not press oil seal over the first shoulder otherwise the oil return drilling will be covered.



REMOVING AND INSTALLING CAMSHAFTS

=====

Removing:

- Remove upper toothed belt guard.
- Remove intake manifold.
- Remove cylinder head cover.
- Rotate engine until No. 1 cylinder is at TDC.
- Release tension of toothed belt at coolant pump and remove.
- Remove camshaft sprocket.

Exhaust camshaft:

- ◀ - Remove bearing cap in front of chain, as well as caps 2 and 4.
- Slacken bearing caps 1, 3 and 5 alternately in diagonal sequence.

Inlet camshaft:

- Remove bearing cap in front of chain, as well as caps 7 and 9.
- Slacken bearing caps 6, 8 and 10 alternately in diagonal sequence.

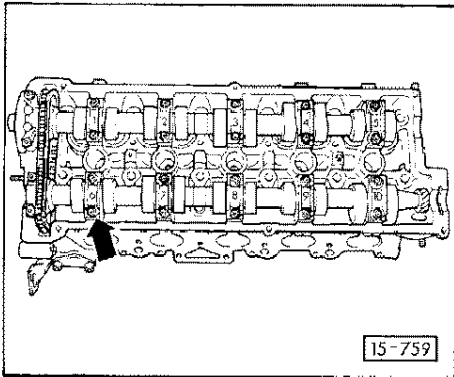

15-19

Installing:

- ◀ - Fit camshafts with chain so that markings on chain sprockets align (arrows).

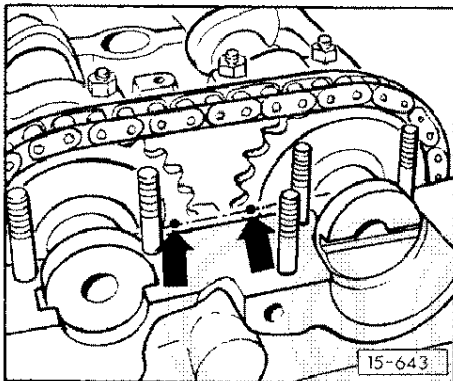

Caution

When installing the bearing caps, ensure that the recesses (corners) of the caps face towards the intake side of the cylinder head - page 15-10.

Remove distributor before installing camshaft.

Fitting distributor - Repair Group 28

Distributor basic setting - Repair Group 28

Inlet camshaft:

- ◀ - Tighten bearing caps 6, 8 and 10 alternately and in diagonal sequence.

Tightening torque: 15 Nm.

commercial purposes, in part or in whole, is not

permitted without the prior written consent of the

author. All rights reserved. © 2000 Volkswagen

AG. All other rights reserved. This document is

intended for use only in conjunction with the

relevant technical information. The information

contained herein is for informational purposes

only and does not constitute a warranty. The

information is subject to change without notice.

Information is provided for informational purposes

only and does not constitute a warranty. The

information is subject to change without notice.

Fit remaining bearing caps.

Tightening torque: 15 Nm

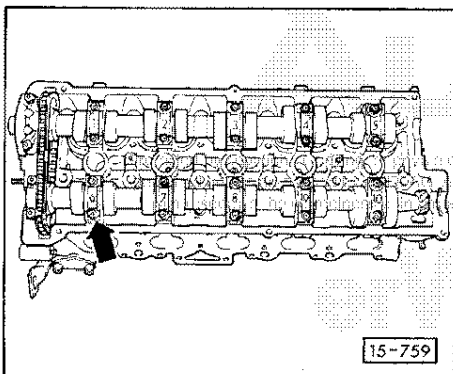

15-20

Exhaust camshaft:

- Tighten bearing caps 1, 3 and 5 alternately and in diagonal sequence.
Tightening torque: 15 Nm.
- Fit remaining bearing caps.
Tightening torque: 15 Nm.
- Fit camshaft seals - page 15-18
- Fit camshaft sprocket and tighten.
Tightening torque: 67 Nm.
- Install toothed belt.
(Adjusting valve timing - Repair Group 13).

Caution

When new tappets have been installed, the engine must not be started for about 30 minutes (valves will strike pistons).

15-21

CHECKING AND RENEWING VALVE GUIDES

Checking valve guides

When servicing engines with leaking valves, it is not sufficient to rework or renew the valve seats and valves. It is also necessary to check the valve guides for wear. This is particularly important when checking engines with high mileage.

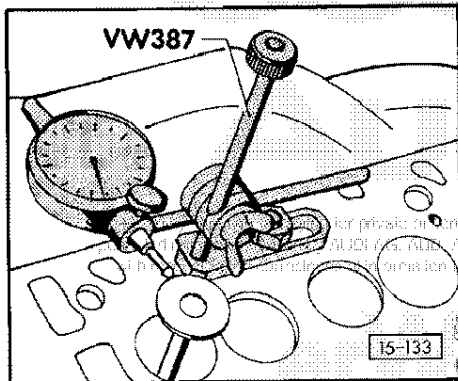

- Insert new valve into guide until end of valve stem is flush with end of guide. Due to the difference in stem diameters, ensure that only an inlet valve is used in the inlet guide and an exhaust valve in the exhaust guide.

For private or non-commercial purposes. In part or in whole, it is not permitted to reproduce, distribute, or otherwise use the content of this document. Copyright by AUDI AG.

- Determine rock.
Wear limit:
Inlet valve guide = 1.0 mm
Exhaust valve guide = 1.3 mm

15-22

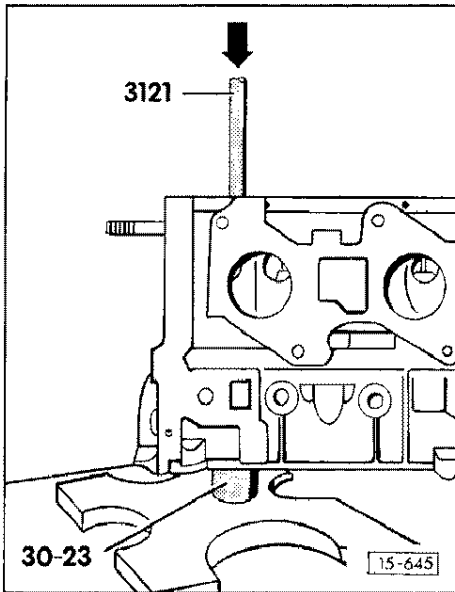

Renewing valve guides

Cylinder heads in which the valve seats can no longer be reworked, or cylinder heads which have already been machined to the minimum dimension, should no longer be repaired.

- ← Press worn valve guides out from the combustion chamber side using 3121. By way of support, use sleeve 30-23 during this operation.

15-23

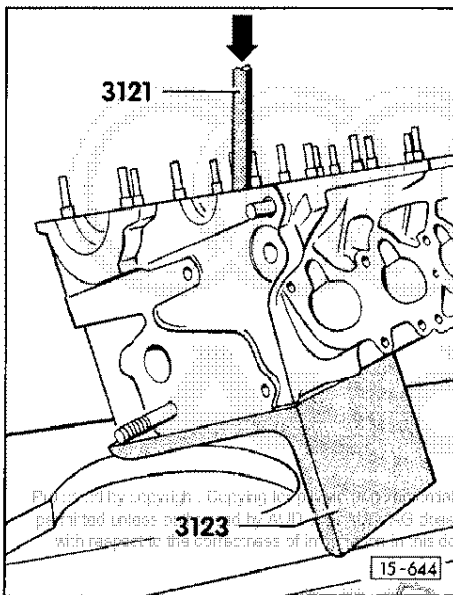

- ← Coat new guides with oil and press in using 3121 from camshaft side with head cold until shoulder makes contact.

Note:

- Use support 3123 for pressing inlet valve guides in.

Caution

When the shoulder on guide makes contact, the pressure must not exceed 1.0 tonnes otherwise shoulder may break off.

Ream guides with hand reamer 3120, using plenty of cutting fluid.

- Rework valve seats.

Note:

When reworking valve seats, watch minimum dimension - page 15-13.

15-24

RENEWING VALVE STEM OIL SEALS

=====

(with cylinder head in situ)

- Remove camshaft and bucket tappets.
- Remove spark plugs.
- Set piston of appropriate cylinder to "BDC".
- Screw compressed air hose VW 653/3 into plug thread and apply a continuous pressure of

minimum 6 bar

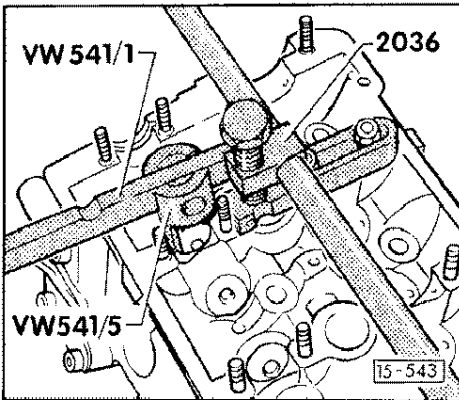

Inlet side:

- Install fitting appliance 2036 and adjust to height of studs.
- Remove valve springs with valve lever VW 541/1 and adapter VW 541/5.

15-25

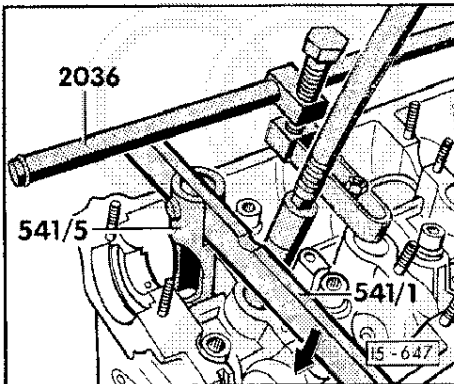

Exhaust side:

- Note:
- Tight cotters can be loosened by tapping lightly on the lever of the tool VW 541/1.

Protected by copyright. Copying for private or commercial purposes in part or in whole is not permitted unless authorised by AUDI AG. AUDI AG does not guarantee or accept any liability for the completeness or correctness of information in this document. Copyright by AUDI AG.

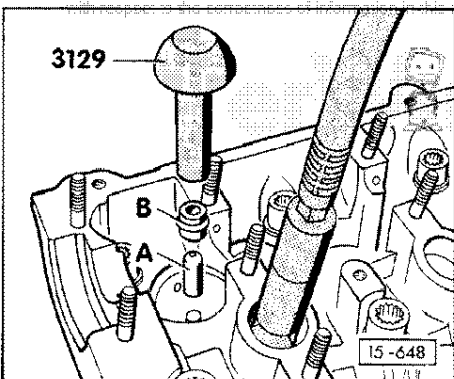

- Install valve stem seals.
Fit plastic sleeve -A- onto valve stem. Oil valve stem seal -B-, place it in fitting tool 3129 and push it down carefully onto the valve guide.

Caution
To prevent damaging the valve stem seal, always use the plastic sleeve.

15-26

RENEWING VALVE STEM OIL SEALS

=====

(Cylinder head removed)

- Remove camshaft and bucket tappets.
- Remove spark plugs.

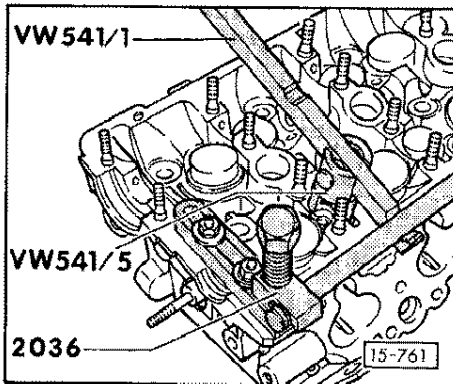

Inlet side:

Note:

Loosen tight valve cotters by lightly tapping the assembly lever VW 541/1 with a hammer.

- ◀ - Install fitting appliance 2036 and adjust to height of studs.
- Remove valve springs using valve lever VW 541/1 and adapter VW 541/5.

15-27

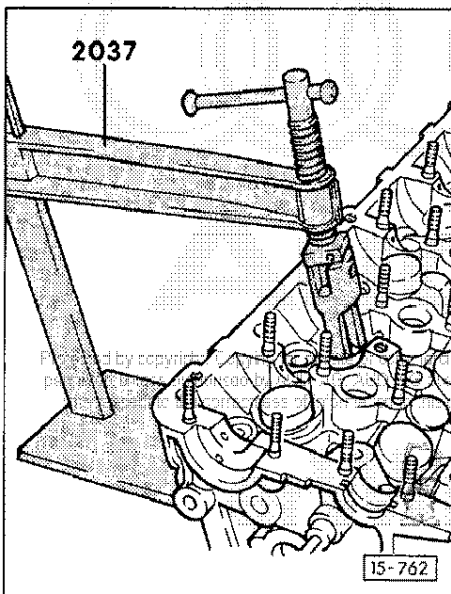

Exhaust side:

Remove valve springs using 2037.

Printed by copyright for technical purposes in part or in whole is not permitted without the prior written consent of the manufacturer. Copyright by AUD AG

- Remove valve stem seals using 3047 A.

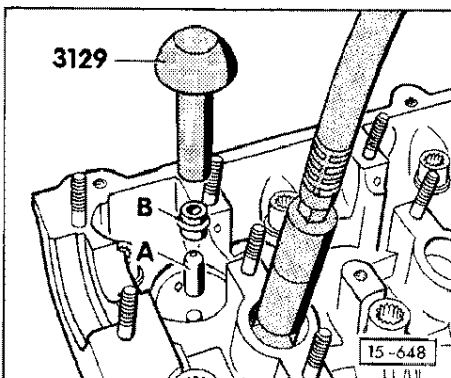

- ◀ - Install valve stem seals.
Fit plastic sleeve -A- over valve stem. Coat valve stem seal -B- with oil, place in fitting tool 3129 and carefully slide over valve guide.

Caution

Always use the plastic sleeve when fitting valve stem seals to prevent damage.

15-28

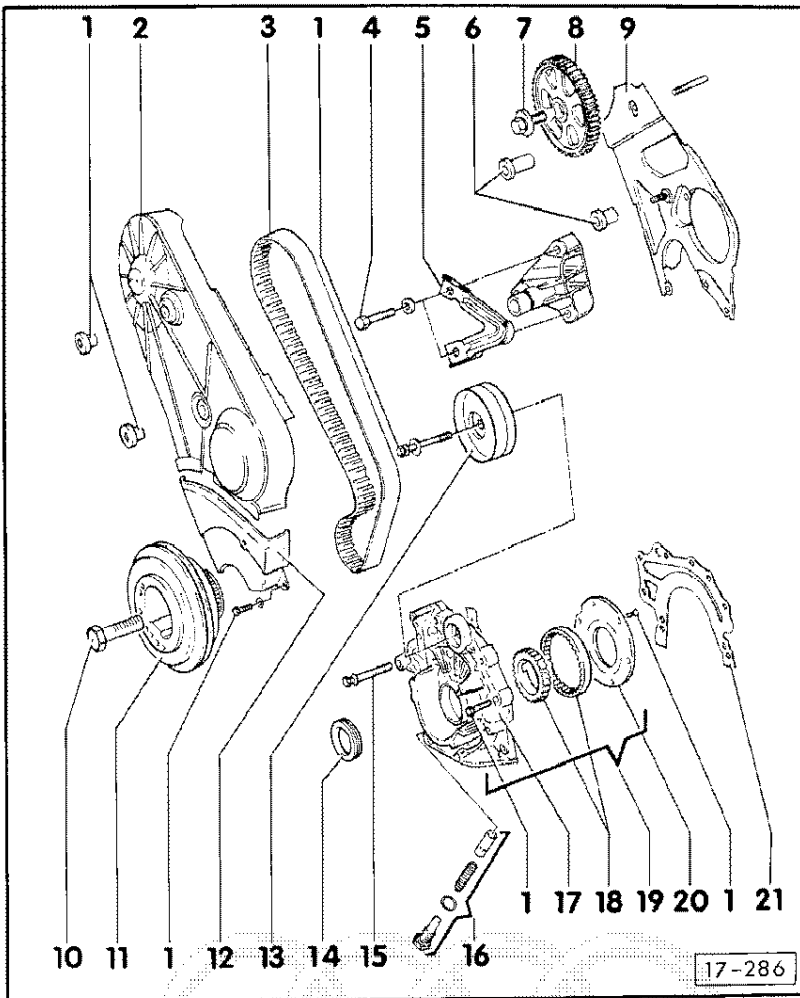

REMOVING AND INSTALLING LUBRICATION
 =====
 SYSTEM COMPONENTS
 =====

Note:
 All parts shown in the illustration
 can be removed and installed with engine
 fitted.

- 1- 10 Nm
- 2- Upper toothed belt guard
- 3- Toothed belt
 - Fitting/tensioning - Repair Group 13
- 4- 43 Nm
- 5- Vee-belt deflection limiter (right)
- 6- Spacer bushes
 - Long spacer bush top
 - Short spacer bush bottom
- 7- 57 Nm
- 8- Camshaft sprocket
 - Note observe position when fitting toothed belt - Repair Group 13
- 9- Rear toothed belt guard

17-286

17-1

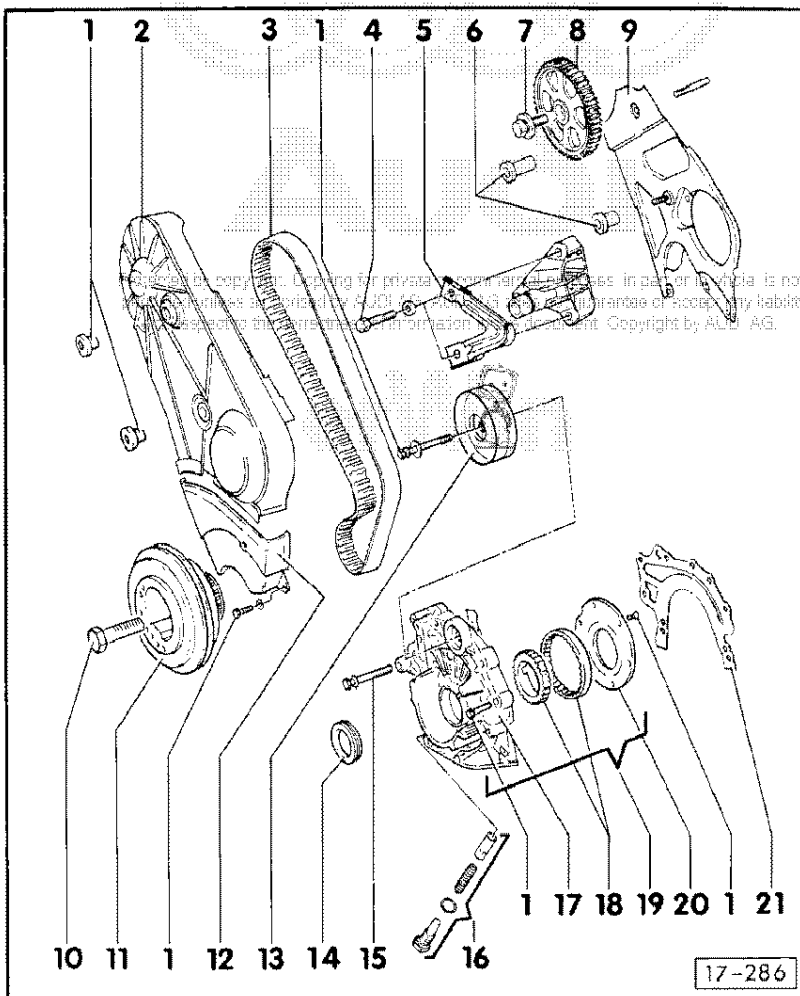

- 10- 350 Nm
 - Tightening torque applies only when using special tools 2079 and 2084 - Repair Group 13.
 - Coat threads and seating surface of bolt head with sealing compound AMV 188 00 02.
 - Loosening and tightening - Repair Group 13.
- 11- Vibration damper
 - Removing and installing - Repair Group 13.
- 12- Lower toothed belt guard.
- 13- Idler pulley
 - Removal - page 17-11
- 14- Oil seal
 - Removal - page 17-12
 - Fitting - page 17-12
- 15- 20 Nm
- 16- Oil temperature sender (G8) and oil pressure relief valve (45 Nm)
 - Opening pressure: 6.0 ... 6.5 bar
- 17- Oil pump housing
- 18- Oil pump gears
 - The mark faces towards the cover plate

17-286

17-2

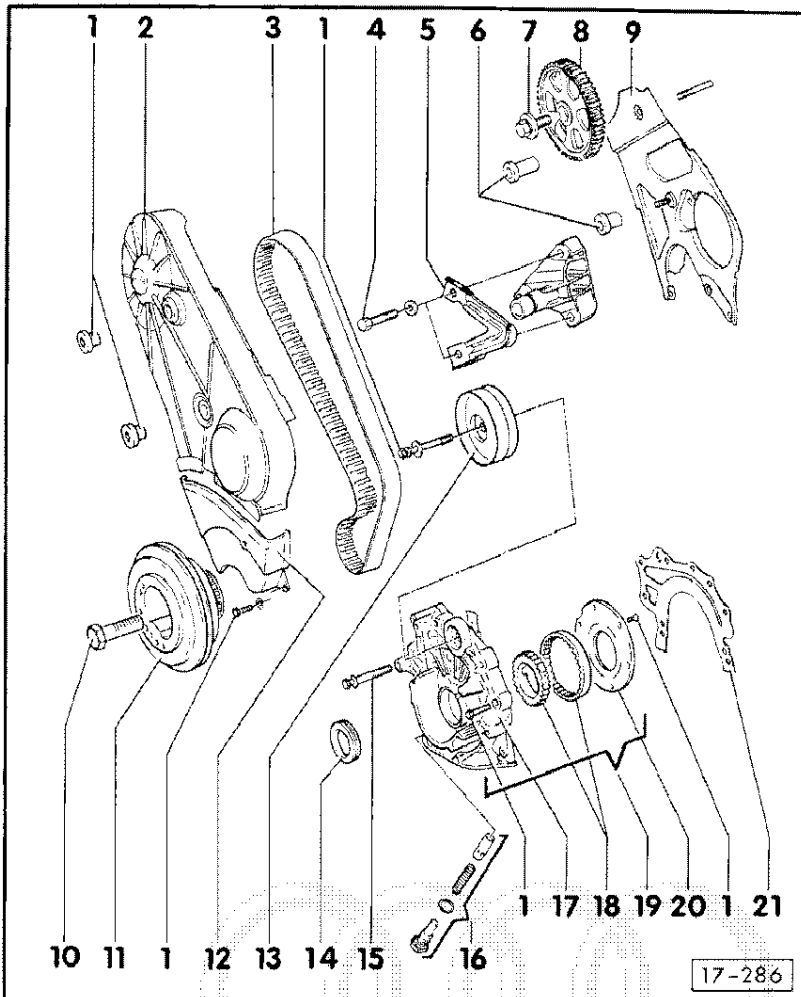

- 19- Oil pump
 - Renew only as a complete unit
 - Observe crankshaft drive dog when fitting pump.
- 20- Cover plate
- 21- Oil pump gasket
 - Renew

17-3

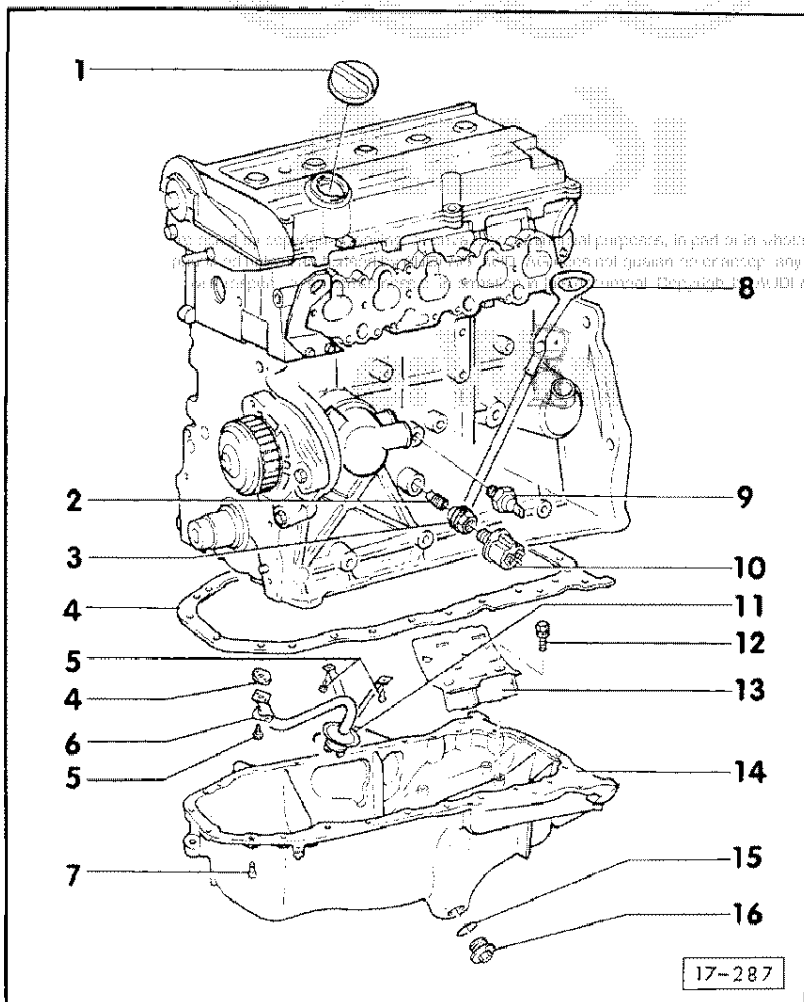

If during repairs the engine oil is found to be contaminated (swarf or metal particles caused by partial seizure of e.g. the big end or crankshaft bearings), the oil galleries must be cleaned carefully to prevent further damage.

Tighten oil sprayjet for piston cooling to 10 Nm.

- 1- Cap
 - Renew seal if damaged
- 2- Oil check valve 6 Nm
 - Remove and fit using commercial multi-point socket driver (8 mm)
 - Apply D6 locking fluid before fitting
- 3- Adapter 50 Nm
- 4- Gasket
 - Renew
 - Do not use adhesive
- 5- 10 Nm
- 6- Lock plate
 - Renew
- 7- M 6 - 10 Nm
M 8 - 20 Nm

17-4

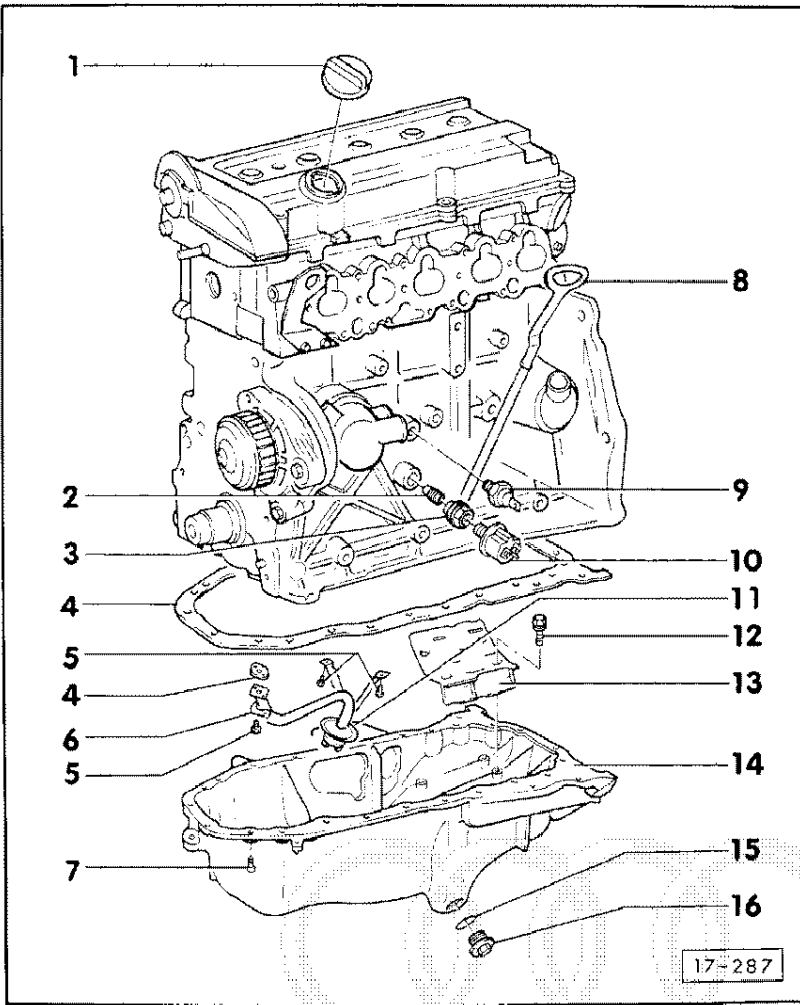

- 8- Dipstick
- 9- Oil pressure switch (white), 25 Nm
 - 1.8 bar
 - Checking - page 17-13
- 10- Oil pressure switch, 25 Nm
 - Checking - page 17-15
- 11- Intake pipe
 - Secure to oil pump first
- 12- 10 Nm
- 13- Baffle plate
- 14- Sump
 - Removing and installing:
Remove front subframe securing bolts - page 17-9
 - Clean sealing surface before installing
- 15- Seal
 - Renew
- 16- 30 Nm

17-287

17-5

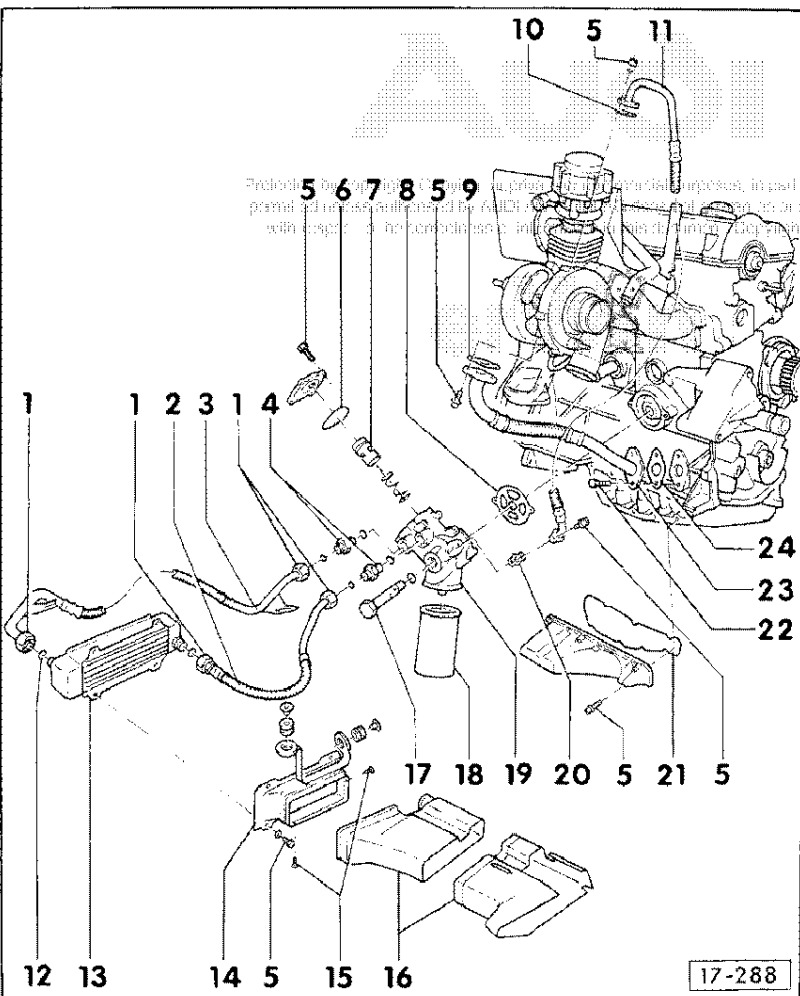

- Note:
- Always renew gaskets
 - Oil capacity: 4.0 l without oil filter change
4.5 l with oil filter change
- 1- 40 Nm
 - 2- Flow line (oil cooler)
 - 3- Return line (oil cooler)
 - 4- Adapter 50 Nm
 - 5- 10 Nm
 - 6- Oil thermostat seal
 - Renew
 - 7- Oil cooler thermostat
 - 8- Oil filter housing gasket
 - Renew
 - 9- Oil return line gasket (turbo-charger)
 - Renew
 - 10- Flow line gasket (turbocharger)
 - Renew

17-288

17-6

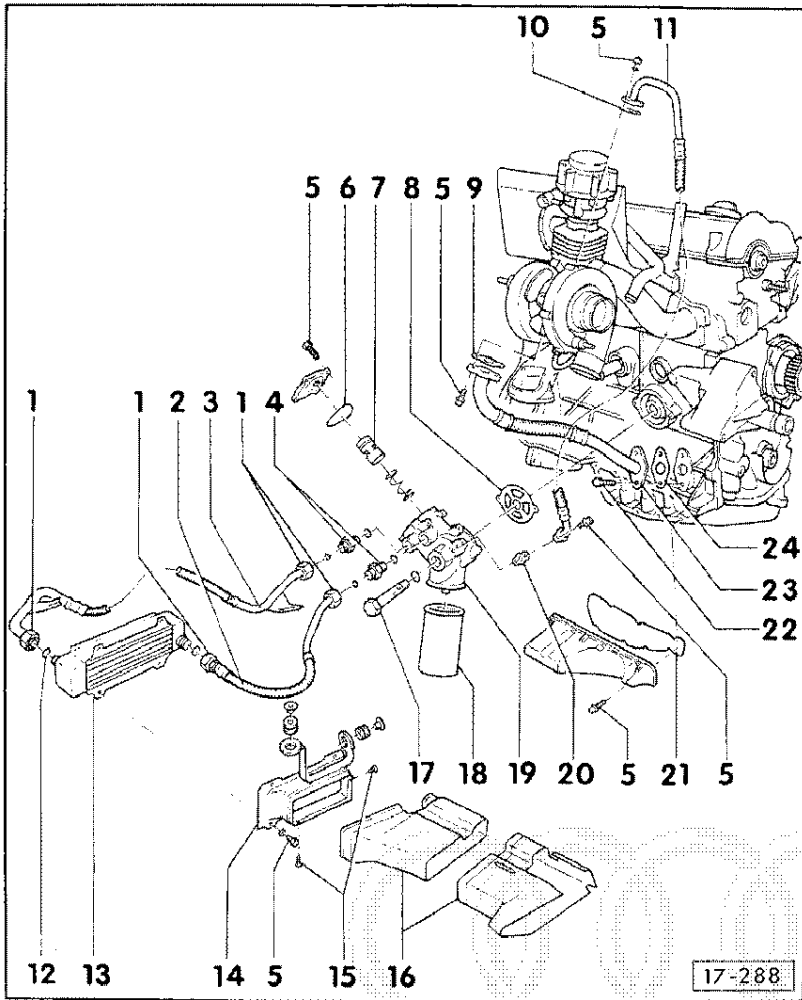

- 11- Flow line (turbocharger)
- 12- O-ring seal
 - Renew
- 13- Oil cooler
- 14- Oil cooler bracket
- 15- Self-tapping screw
 - For securing air duct
- 16- Air duct
- 17- Banjo bolt 70 Nm
- 18- Oil filter 20 Nm
 - Release using strap wrench, tighten by hand
 - Observe installation instructions printed on oil filter.
- 19- Oil filter housing
- 20- Flow line gasket (turbocharger) on oil filter housing
 - Renew
- 21- Gasket
 - Renew
- 22- 22 Nm

17-7

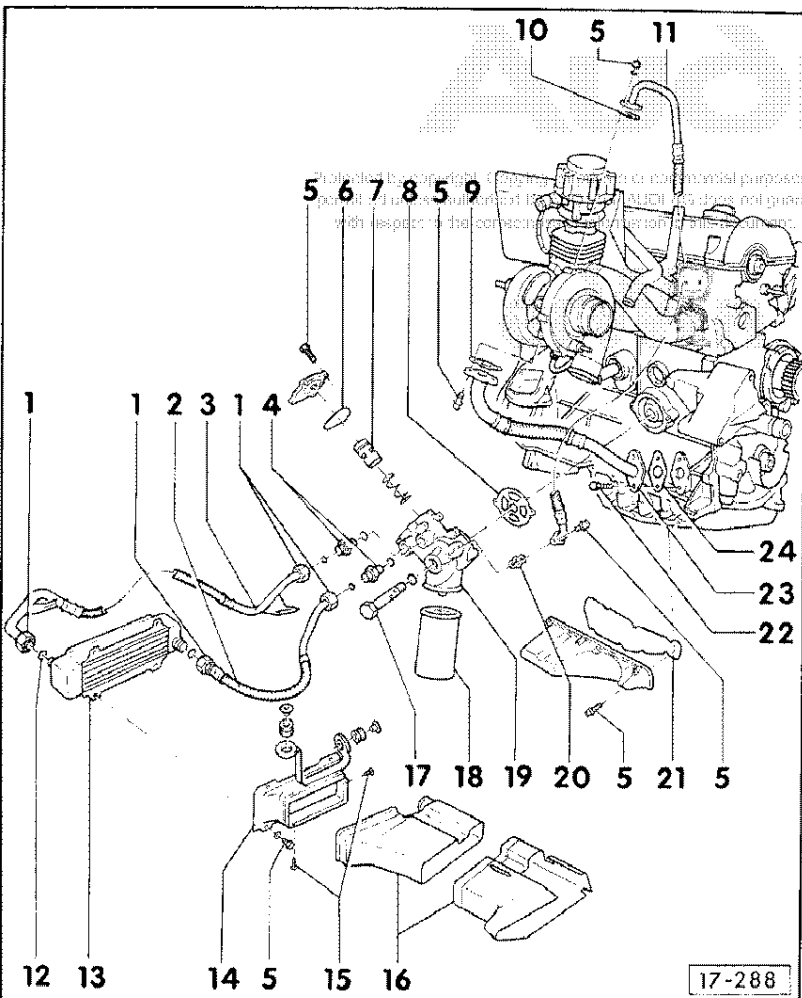

- 23- Return line - turbocharger
- 24- Turbocharger return line/crankcase gasket
 - Renew

17-8

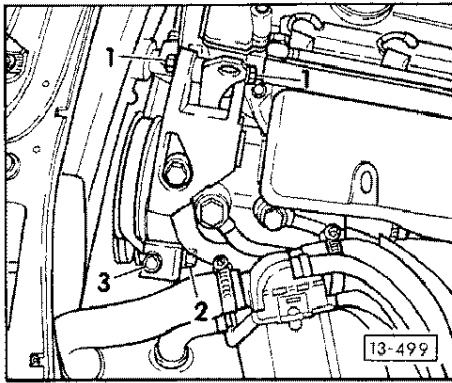

◀ REMOVING OIL PUMP

- Release both bolts -1-, nut -2- and bolt -3- to slacken and remove Vee-belt for alternator, air conditioning compressor and central hydraulics pump.
- Remove pump from hydraulic unit and move to one side (without disconnecting hoses).
- Slacken vibration damper centre bolt - see Repair Group 13.
- Remove toothed belt guard.

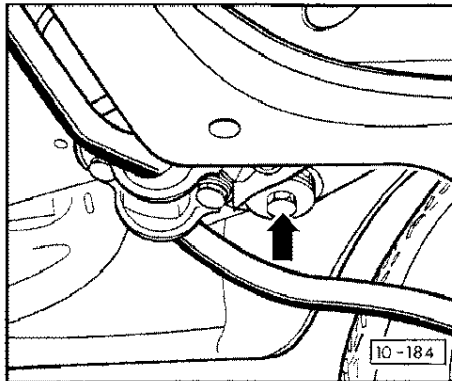

◀ Removing oil sump

Caution
The subframe will suddenly drop by approx. 100 mm.

- Remove both front subframe bolts.

Note:
These two subframe bolts must be renewed.

- During refitting the two subframe bolts should be tightened to 65 Nm plus a quarter turn.
- Remove oil dipstick.
- Drain engine oil.

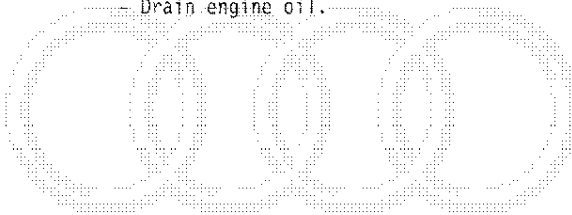

17-9

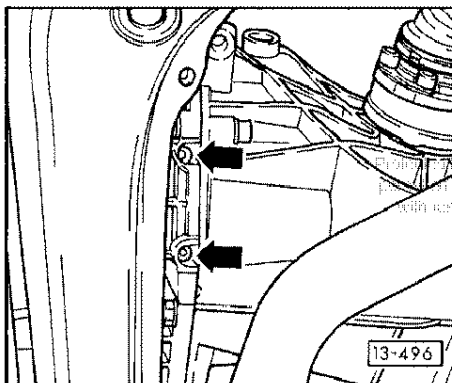

- ◀ There are two cutouts at the flywheel end of the sump (see arrows). The bolts accessible via these cutouts are 5 mm hexagon socket head screws.
- When fitting the sump these bolts should first be screwed in fingertight and then tightened to 10 Nm (M 6) and 22 Nm (M 8).

Copyright © 2007 Audi AG. All rights reserved. Copying, or prior or subsequent publication, in part or in whole, is not permitted without the express written authorization of Audi AG. Audi AG does not guarantee or accept any liability with respect to the correctness of information in this document. Copyright by Audi AG.

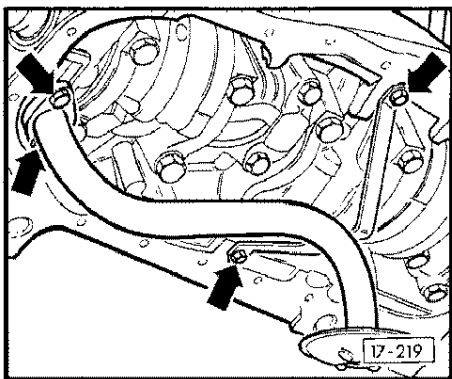
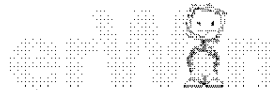

- ◀ - Remove oil suction line.

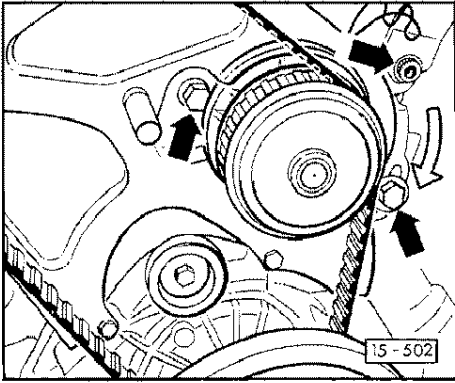

- ← - Release toothed belt and remove. To do this, loosen coolant pump and turn in direction of arrow (clockwise).

Important
Crankshaft must not be rotated further.

- Remove vibration damper with toothed belt pulley.

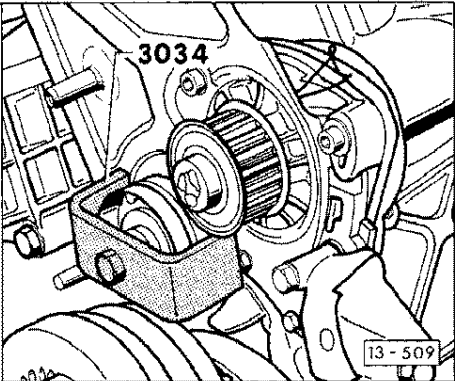

- ← - Remove idler pulley with 3034.
 - It is only necessary to remove the idler pulley when renewing the oil pump and if the idler pulley bearings are damaged. Only the securing bolt has to be removed to take out the oil pump.
- Remove oil pump.



17-11

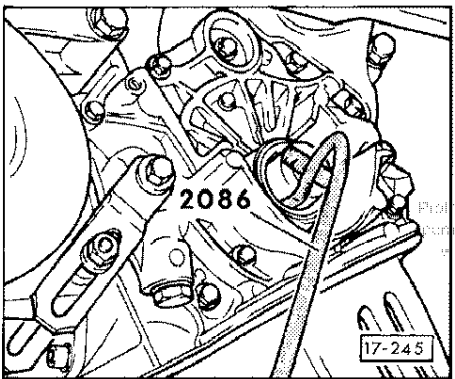

- ← - Remove crankshaft oil seal, pulley end.



Protected by copyright. Copying for private or commercial purposes in part or in whole is not permitted unless authorized by AUDI AG. AUDI AG does not guarantee or accept any liability with respect to the correctness of information in this document. Copyright by AUDI AG

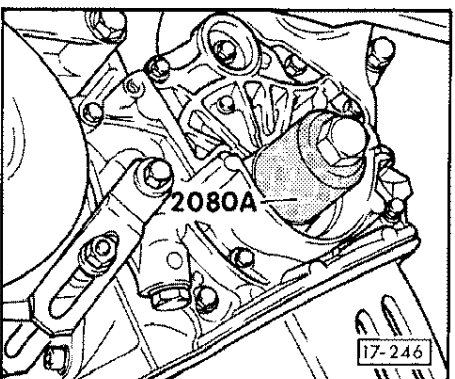

- ← - Press in crankshaft, oil seal pulley end, so that it is flush.
- Use vibration damper mounting bolt for pressing oil seal in.
- Before installing, lightly oil sealing lip and outer edge of oil seal.

Caution
If the crankshaft shows signs of scoring, press on seal as far as it will go.

- Offer up sealing ring with sleeve from 2080 A.
- Press-in seal using thrust sleeve (part of 2080 A).

CHECKING OIL PRESSURE SWITCH AND OIL PRESSURE

(Audiovisual oil pressure indication)

Test conditions:

- Oil level O.K.
- Oil pressure indicator (K3) must glow when ignition is switched on.
On vehicles with auto check system the indication must be O.K. (Call up symbols).
- Minimum engine oil temperature: 80 deg. C. (radiator fan must have cut in once).

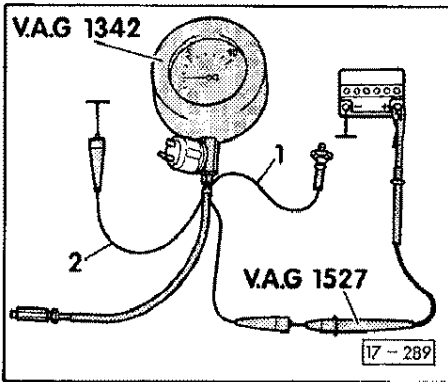

Oil pressure switch 1.8 bar

- Remove cables from oil pressure switch and oil pressure sender.
- Unscrew oil pressure sender and screw into oil pressure sender test unit V.A.G 1342.
- ← - Screw V.A.G 1342 into the crankcase in place of the oil pressure sender.
- Connect wire -2- (brown) to earth (-).
- Connect wire -1- (blue) to 1.8 bar oil pressure switch (white insulation).

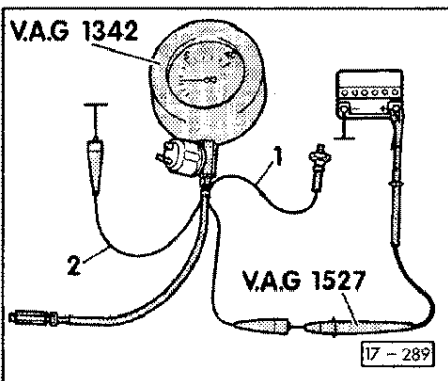

- ← - Connect diode test lamp V.A.G 1527 to wire -1- and positive battery terminal.
- Start engine.
- Slowly increase engine speed.
The test lamp should illuminate at 1.6 ... 2.0 bar. If this is not the case the oil pressure switch must be renewed.
- Increase engine speed further.
At 2000 rpm and an oil temperature of 80 deg. C the oil pressure must be at least 2.0 bar.
- ← - Increase engine speed further in this document. Copyright by AUDI AG.
Pressure relief valve working pressure:
5.0 ... 8.0 bar.
This pressure should not be exceeded except by a minimal amount.

Note:

- If the oil pressure is excessive (pressure relief valve sticking or incorrectly fitted) the hydraulic tappets will be subjected to excessive pressure. As a result the engine will cut out soon after starting and turn over noticeably fast during subsequent starting because of lack of compression.
- If the wires are incorrectly connected to be oil pressure sender the auto check system will cause the engine oil pressure warning symbol to illuminate (oil can).

CHECKING OIL PRESSURE SENDER (G 10)

Test conditions:

- Oil level O.K.
- Oil pressure warning lamp (K 3) must glow when ignition is switched on.
On vehicles with auto check system the indication must be O.K. (Call up symbols).
- Minimum engine oil temperature: 80 deg. C. (radiator fan must have cut in once).
- Tachometer in electronic instrument panel assembly O.K.

Notes:

- Check auto check system or oil pressure sender (G10) if the oil pressure indicator light (K3) does not illuminate.
- For oil pressure sender (G10) mounting position see page 17-5 item 10.

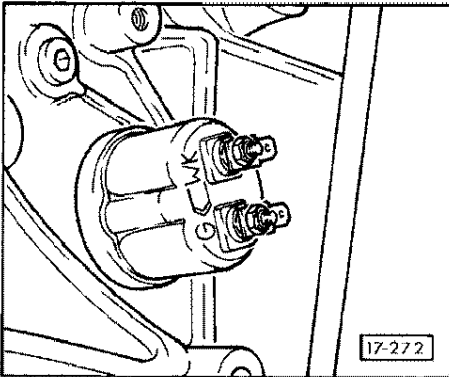

- ◀ - Disconnect wire from oil pressure sender contact G.
- Connect test unit V.A.G. 1526 between oil pressure sender contact G and engine earth using the auxiliary cable from V.A.G. 1594.
- Switch V.A.G 1526 to the 200 ohm range;
Specified reading: 5 ... 10 ohms.
- Start engine and run at idling speed.
Specified reading: 70 ... 120 ohms.
- Increase engine speed to 3000 rpm.
Specified reading: 170 ... 200 ohms.

17-15

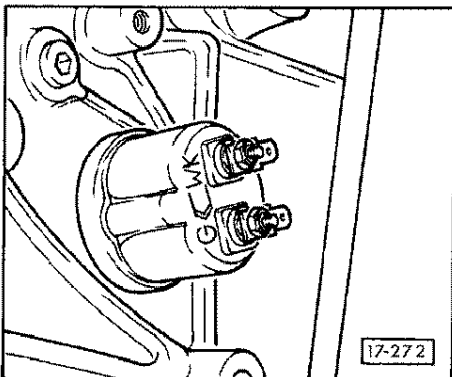

- ◀ - Connect V.A.G 1526 test unit between oil pressure sender contact WK and engine earth using the auxiliary cable from V.A.G 1594.
- Start engine and run at idling speed.
Specified reading: infinite ohms.
- Switch off engine.
Specified reading: 0 ... 0.5 ohms.
- If these values are not obtained the oil pressure sender (G10) should be replaced.

Protected by copyright. Copying for private or commercial purposes, in part or in whole, is not permitted unless authorized by AUDI AG. AUDI AG does not guarantee or accept any liability

Note: Incorrect wiring of the oil pressure sender will cause the auto check system to display the engine oil pressure warning symbol (oil can).



REMOVING AND INSTALLING COOLING SYSTEM

COMPONENTS

Draining and refilling coolant -
page 19-6
Checking cooling system for leaks -
Fig. 1.
Thermostat - Fig. 3

Note:
Always renew gaskets and seals.

- 1- Auxilliary radiator
- 2- Coolant hose
(Between auxiliary radiator and main radiator)

- 3- Thermo switch 25 Nm for electric fan

Switch	Switching temperature	
	On	Off
3-pin + = supply		
1 = 1st stage	92 .. 97°	84 approx
2 = 2nd stage	99 .. 105°	91 approx

- 4- Seal
● Renew
- 5- 10 Nm
- 6- Radiator cowl
- 7- Radiator fan

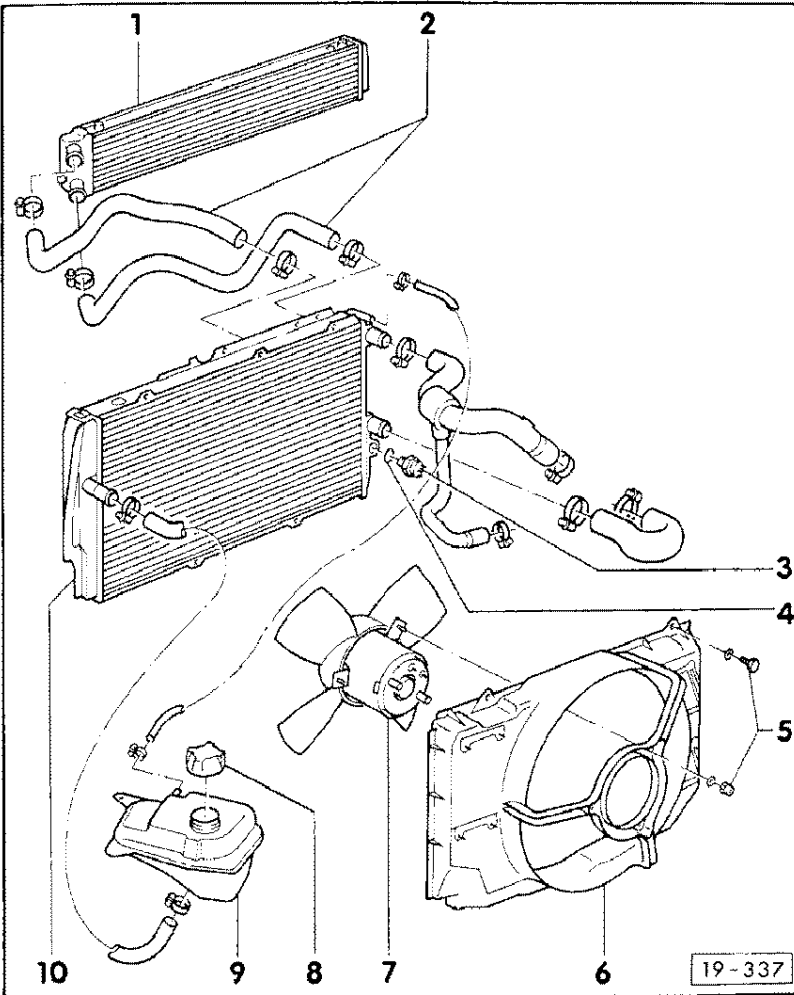

19-1

- 8- Cap
● For testing see Fig. 2.
- 9- Expansion tank
● For filling and checking tank
see page 19-8
- 10- Radiator
● Removing and installing
● Remove fasteners and coolant
hoses and withdraw radiator
vertically.

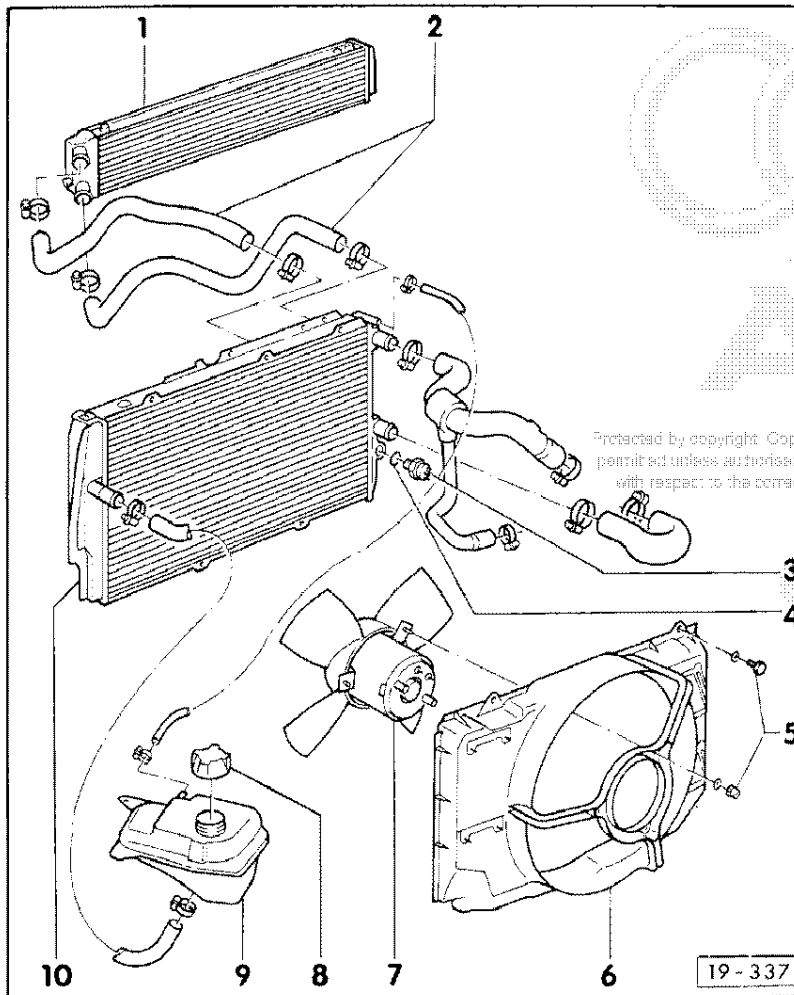

Protected by copyright. Copying for private or commercial purposes, in part or in whole, is not permitted unless authorised by AUDI AG. AUDI AG does not guarantee or accept any liability with respect to the correctness of information in this document. Copyright: by AUDI AG.

19-2

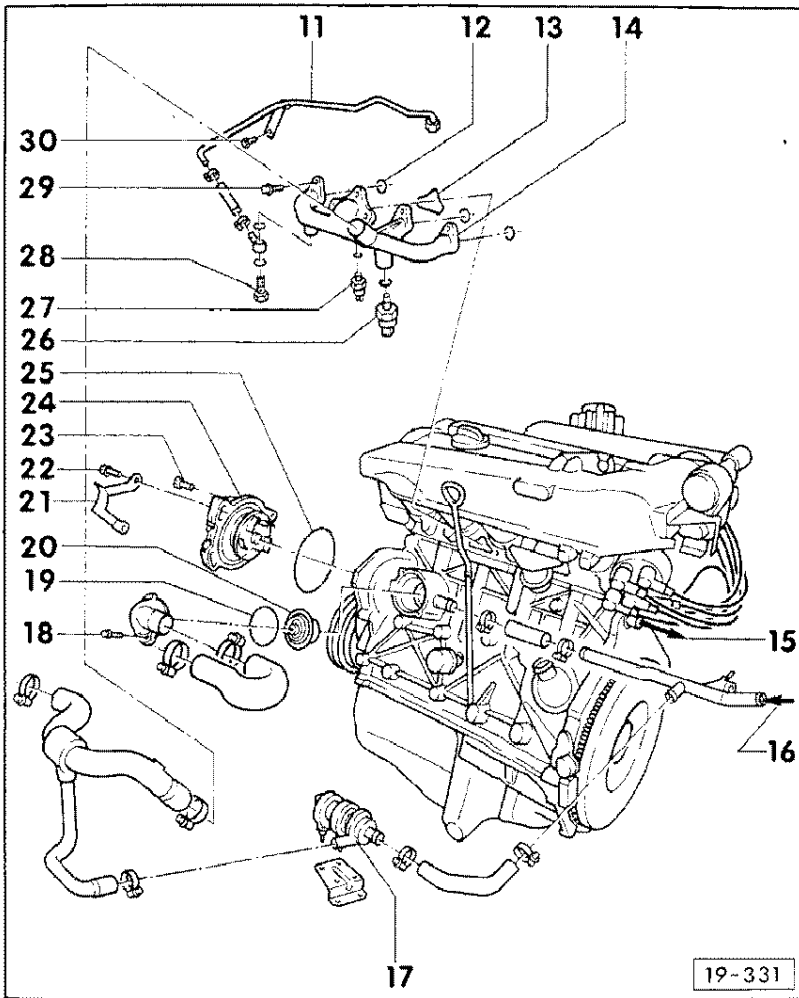

- 11- Coolant flow to turbocharger
- 12- O-ring seal
● Renew
- 13- Gasket
● Renew
- 14- Coolant manifold
- 15- To heat exchanger
- 16- From heat exchanger
- 17- Turbocharger coolant pump
● Checking, page 19-10
- 18- 10 Nm
- 19- Coolant thermostat seal
● Renew
- 20- Coolant thermostat
● Fig. 3
● Opens at 87° approx.
● Fully open at 102° approx.
● Opening stroke 8mm min.
- 21- V-belt deflection limiter (left)
- 22- 22 Nm
- 23- 22 Nm

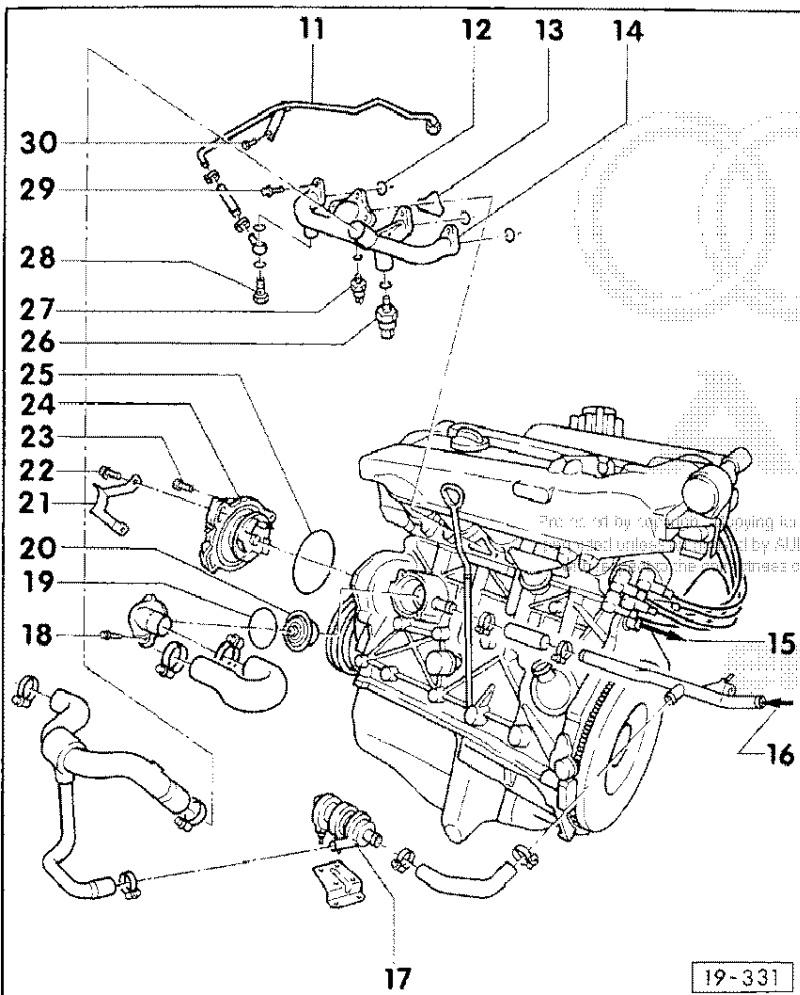

- 24- Coolant pump
- 25- Coolant pump seal
● Renew
- 26- Multi-function switch 25 Nm
● Cannot be tested with normal workshop equipment because of the high switching temperatures.
- 27- Turbocharger coolant pump thermo switch 15 Nm
● Checking, page 19.10
- 28- Banjo bolt 30 Nm
- 29- 10 Nm
- 30- 10 Nm

Printed by Volkswagen Group for private or commercial purposes, in part or in whole, is not permitted unless authorized by AUDI AG. AUDI AG does not guarantee or accept any liability for the accuracy or completeness of information in this document. Copyright by AUDI AG.



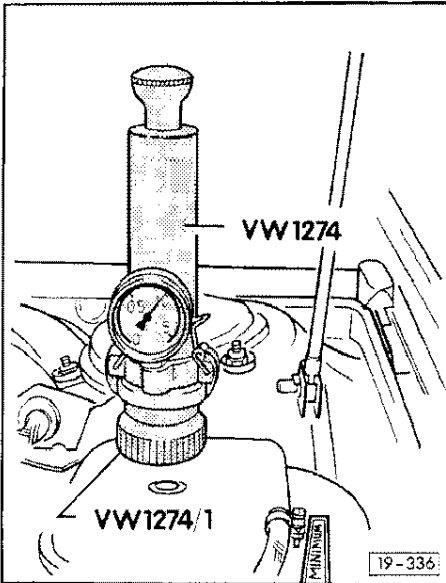

◀ Fig. 1 Checking cooling system for leaks

This test should only be carried out when engine is at operating temperature.

Fit test unit to expansion tank.

Pressurise cooling system to 1.0 bar approx. using the test unit hand pump. If pressure drops locate leak and repair.

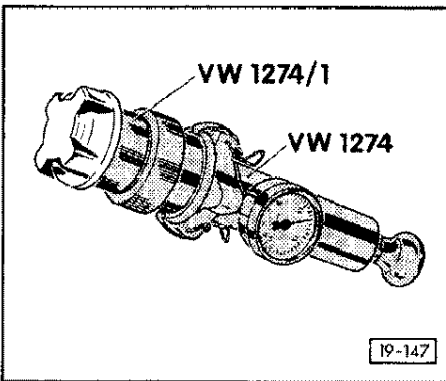

◀ Fig. 2 Checking cap pressure relief valve

Fit cap to test unit.

Pressurise cap using the test unit hand pump.

The pressure relief valve must open at 1.2 ... 1.5 bar.

19-5

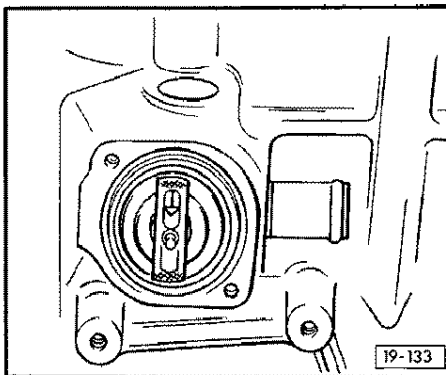

◀ Fig. 3 Thermostat, installation position

Starts opening: 87° approx.
Fully stroke: 102° approx.
Working stroke: 8 mm min.

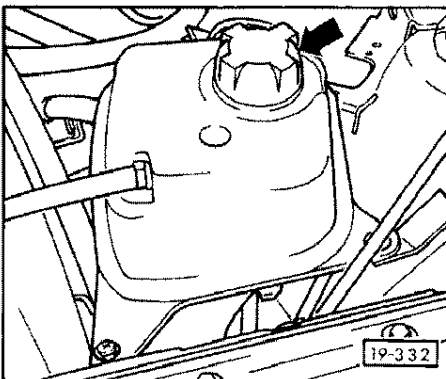

DRAINING AND FILLING COOLING SYSTEM

Draining:

- Set heater controls to hot position.
- Open expansion tank cap.



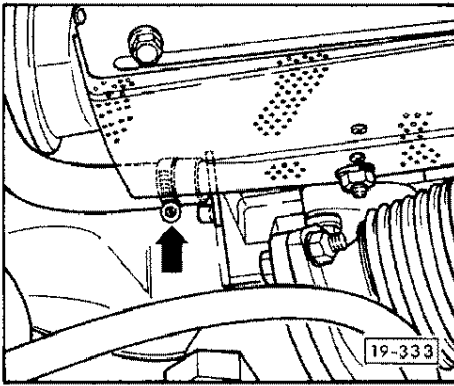

◀ - Drain coolant by detaching coolant hose to heater at rear of engine block. Catch coolant for re-use.

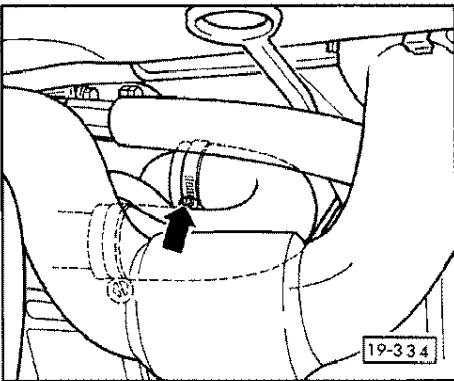

◀ - Detach coolant hose at lower coolant pipe.

19-7

Filling cooling system:

Note:

The cooling system is filled all the year round with a mixture of water and G11 antifreeze.

G11 and coolant additives marked as being "in accordance with TL VW 774 A" prevent freezing, corrosion damage and scale formation and raise the coolant boiling point. For these reasons the cooling system should be filled all the year round with antifreeze and anti-corrosion additive. Due to the high boiling point the coolant is an aid to operational efficiency when the engine is operating on full load, particularly in tropical climates.

Recommended mixture ratios:

Frost protection down to	Volume of G11	Volume of water
- 25°	3.4 l	5.1 l
- 35°*	4.25 l	4.25 l

* For countries with cold climates.

Protected by copyright. Set heater controls to hot. purposes in part or in whole is not permitted unless authorized by AUDI AG. AUDI AG does not guarantee or accept any liability with respect to Fill with coolant until the expansion tank is full.

- Start and run engine.
- Keep topping up expansion tank with coolant until the coolant level drops no further and is slightly above the level mark.

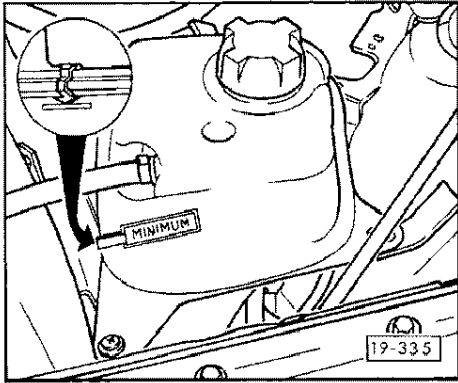

- Replace expansion tank cap.
 - Allow engine to run until the electric radiator fan cuts in.
 - Check coolant level again and top up if necessary.
- ◀ When the engine is at operating temperature the coolant level should be somewhat above the minimum level mark. When the engine is cold the level should at least reach the point of the marker.

19-9

CHECKING TURBOCHARGER THERMO SWITCH AND COOLANT PUMP

- Allow engine to run until the electric radiator fan cuts in.
- Switch off engine.
- After 5 min. approx. the electric coolant pump and radiator fan must switch on.
- If electric coolant pump and radiator fan are not switched on proceed as follows:
 - Disconnect wires from thermostich and connect wires to each other.
- The electric coolant pump and fan should now run.
- If coolant pump and fan run:
 - Renew thermostich.
- If coolant pump and electric fan do not run:
 - Locate and repair fault using current flow diagram.

Protected by copyright. Copying for private or commercial purposes, in part or in whole, is not permitted unless authorized by AUDI AG. AUDI AG does not guarantee or accept any liability with respect to the correctness of information in this document. Copyright by AUDI AG.



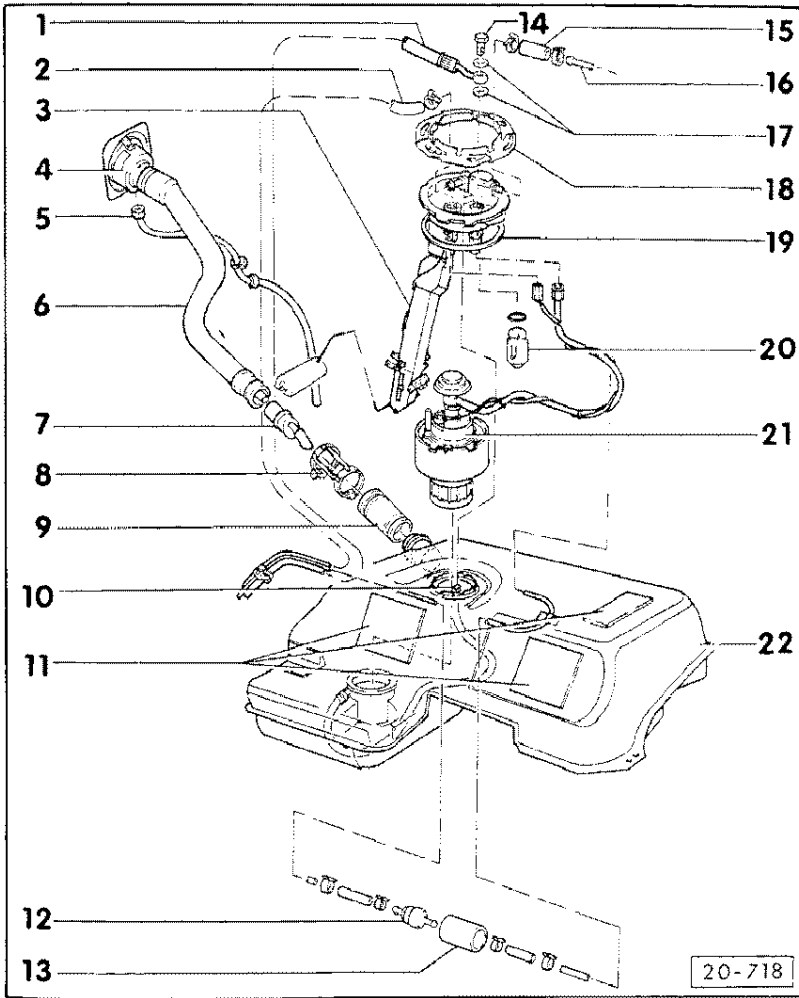

REMOVING AND INSTALLING FUEL SYSTEM
 =====
 COMPONENTS
 =====

Warning
 Always observe the safety rules
 when working on the fuel system.

Note:

- Always renew seals, gaskets and hose clips when working on the fuel system.
- All hoses are secured either with screw or spring-type hose clips.
- Always observe rules of cleanliness - page 20-4.
- Connecting remote control - page 20-5.
- Checking fuel pump relay - page 20-19.
- When removing or installing fuel gauge sender unit ensure that the wires are not damaged.

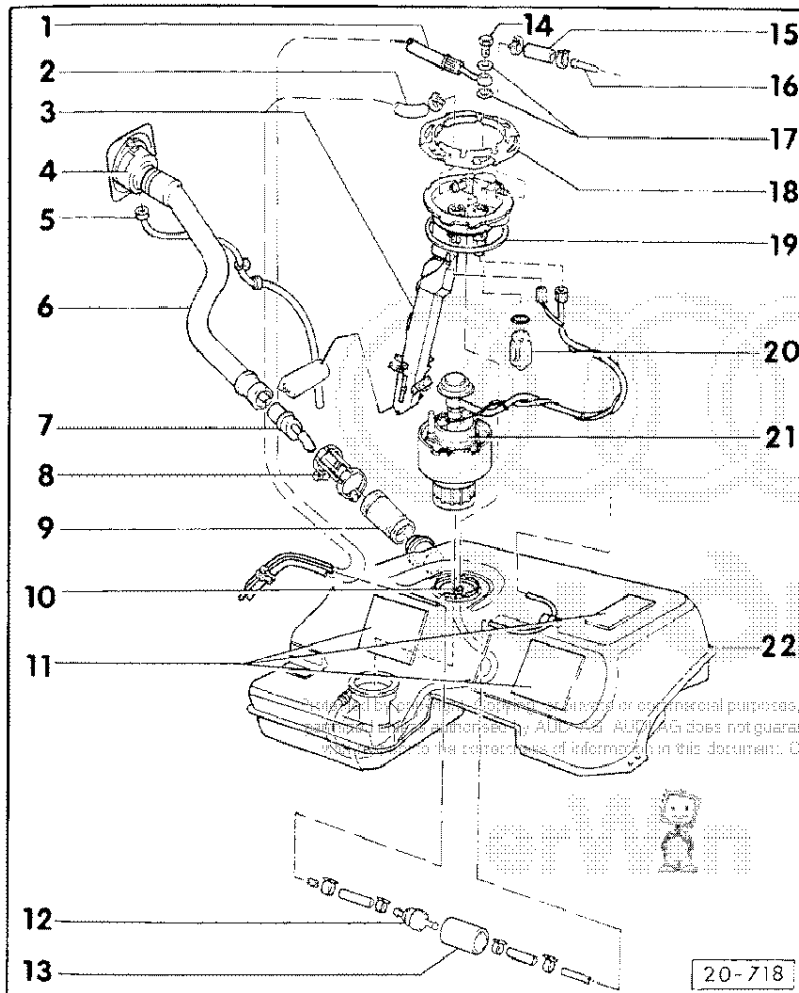

- 1- Fuel supply line
- 2- Fuel return line
- 3- Fuel gauge sender
- 4- Tank filler neck
- 5- Overflow hose
- 6- Tank filler pipe
- 7- Tank filler pipe insert
- 8- Twin hose clip
- 9- Tank filler pipe hose
- 10- Return line
- 11- Packing
- 12- Tank breather/vent valve
- 13- Support hose

This publication is intended for personal or commercial purposes, in part or in whole, is not permitted without the prior written permission of AUDI AG. AUDI AG does not guarantee or accept any liability for the correctness of information in this document. Copyright by AUDI AG

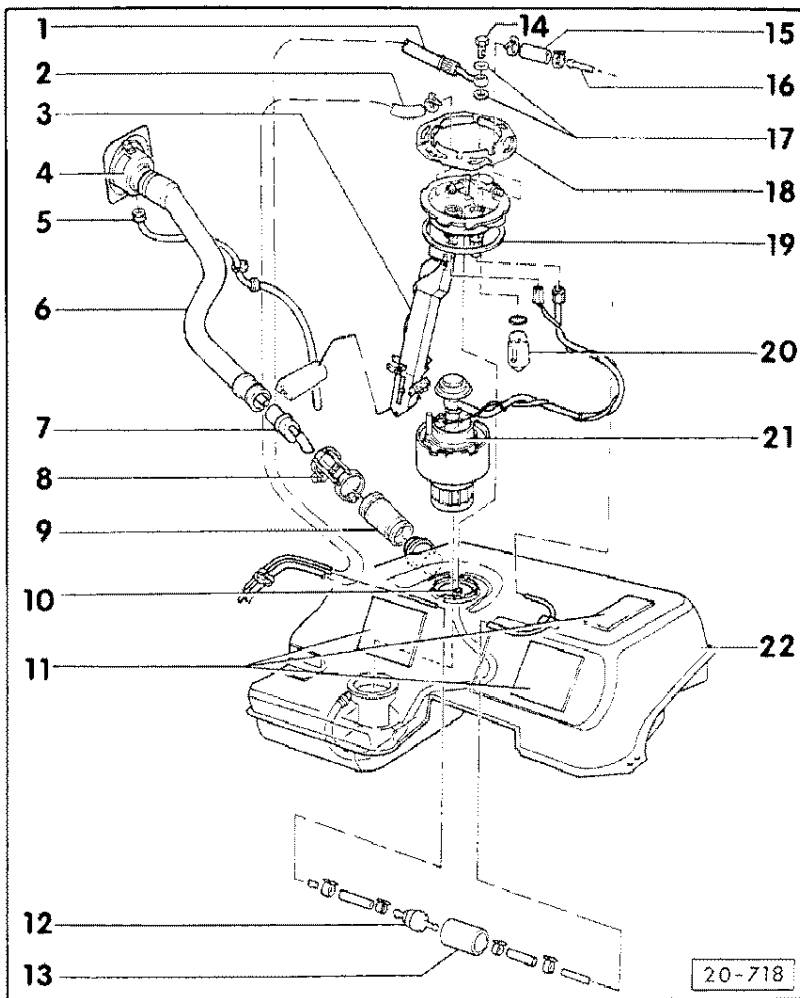

- 14- Banjo bolt 20 Nm
- 15- Ventilation hose
- 16- Ventilation pipe to activated charcoal filter
- 17- Seals
 - renew
- 18- Retainer ring
- 19- Seal
 - Renew
- 20- Gravity valve
- 21- Fuel pump
 - Removal and installation - page 20-8
 - Dismantling and assembling - page 20-11
 - Checking - page 20-12
- 22- Fuel tank

20-3

RULES FOR CLEANLINESS WHEN WORKING ON THE FUEL SYSTEM

Important

When working on the fuel system the following five rules should be observed:

- 1- Thoroughly clean all unions etc. and the adjacent areas before disconnecting.
- 2- Place parts removed from the fuel system on a clean surface and cover against contamination.
- 3- Components that have been opened or dismantled must be carefully covered or sealed if the repair cannot be carried out immediately..
- 4- Only install clean components.
 - Do not remove replacement parts from their packaging until ready for installation.
 - Do not use parts that have been stored without their packaging (e.g. in tool-boxes etc.).

When the fuel system is open:

- Do not use compressed air.
- Do not move the vehicle unless absolutely necessary.

Protected by copyright. Copying for private or commercial purposes, in part or in whole, is not permitted unless authorized by AUDI AG. AUDI AG does not guarantee or accept any liability with respect to the correctness of information in this document. Copyright by AUDI AG.



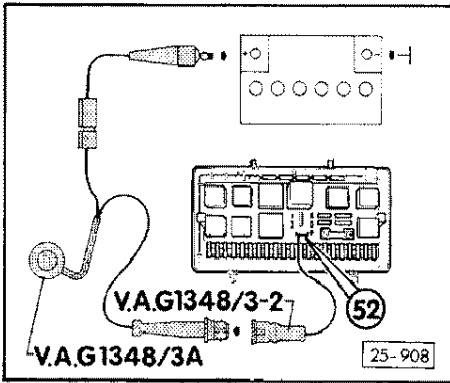

◀ Fig. 1 Connecting remote control V.A.G 1348/3A using adapter cable V.A.G 1348/3-2

- Remove fuel pump relay from relay plate (location 10).
- Connect remote control V.A.G. 1348/3A to contact 52 of relay location 10 and the positive battery terminal using adapter cable V.A.G 1348/3-2.

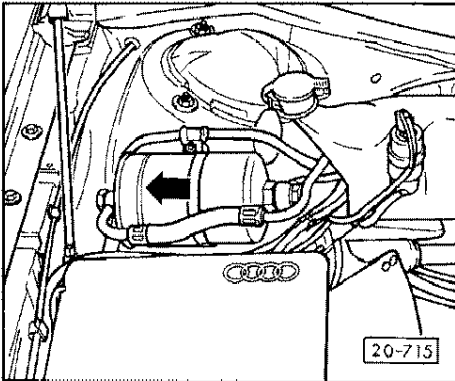

◀ Fig. 2 Fuel filter mounting position

Arrow indicates direction of fuel flow to engine.

20-5

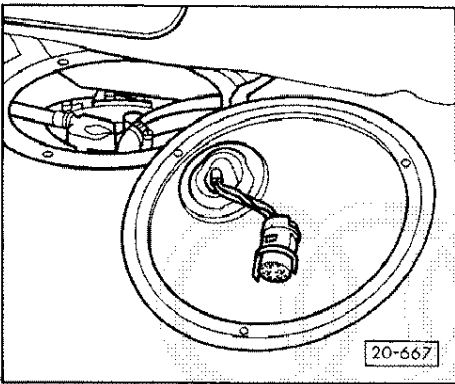

REMOVING AND INSTALLING FUEL GAUGE SENDER

Removal:

- ◀ - Remove fuel gauge sender unit cover (below boot floor trim).
- Pull off connector for fuel gauge and fuel pump.

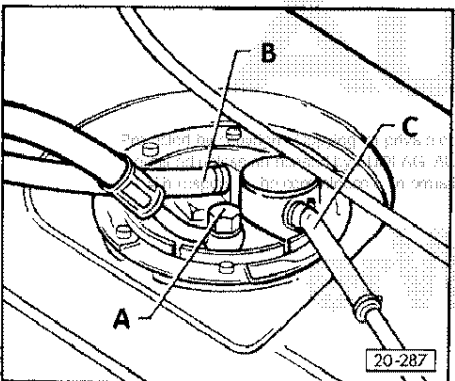

- ◀ - Remove fuel supply line -A-, return line -B- and ventilation line -C-.

Important!
The fuel tank should be not more than 2/3 full.

20-6

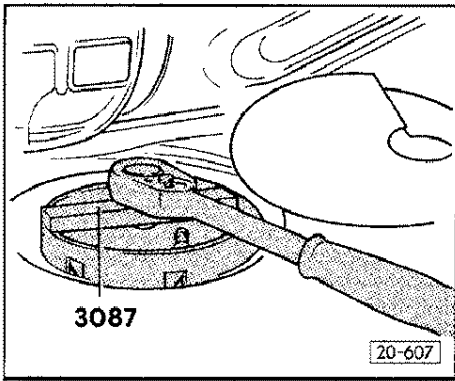

- Release the retainer using special tool 3087 and withdraw the fuel gauge sender from the fuel tank.

Note:

When removing and installing the fuel gauge sender unit ensure that the connecting cables are not damaged.

- Disconnect supply and return lines from the inside of the sender housing.
- Disconnect fuel pump electrical connections.
- Unclip gravity valve.

20-7

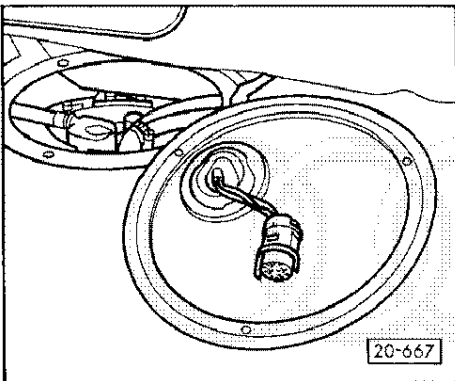

REMOVING AND INSTALLING FUEL PUMP

Removal:

- Remove fuel gauge sender unit cover (below boot floor trim).
- Pull off connector for fuel gauge and fuel pump.

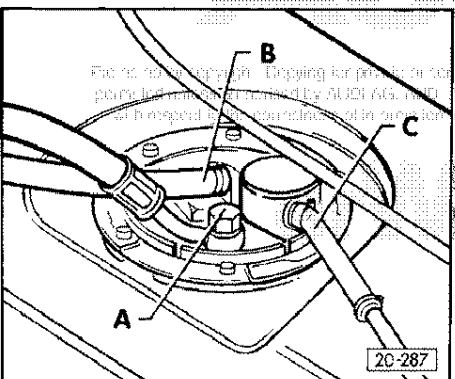

- Remove fuel supply line -A-, return line -B- and ventilation line -C-.

Important!

The fuel tank should be more than 2/3 full.

20-8

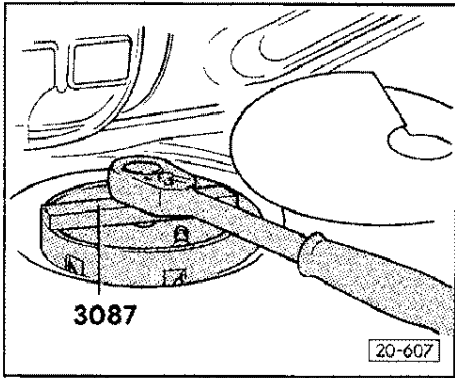

- Release the retainer using special tool 3087 and withdraw the fuel gauge sender from the fuel tank.

Note:

When removing and installing the fuel gauge sender unit ensure that the connecting cables are not damaged.

- Disconnect supply and return lines from the inside of the sender housing.
- Disconnect fuel pump electrical connections.

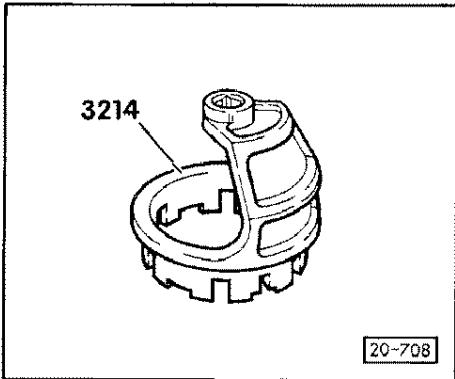

- Rotate pump housing approx. 15mm counter-clockwise using special tool 3214.
- Withdraw pump upwards.

20-9

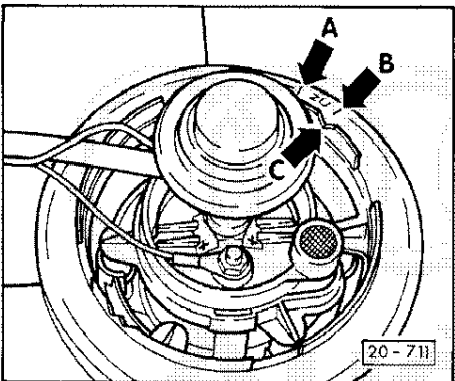

Installing fuel pump

Installation is reversal of removal.

The fuel pump should be installed as follows:

- Fit fuel pump in its fuel reservoir so that the V mark -C- faces mark -A-.
- Fit special tool 3214 to fuel pump.
- Rotate fuel pump clockwise until the V mark -C- faces mark -B-.

Printed with copyright. Copying for private or commercial purposes in part or in whole is not permitted unless authorised by AUD AG. AUD AG does not guarantee or accept any liability with respect to the correctness of information in this document. Copyright by AUD AG



DISMANTLING AND ASSEMBLING FUEL PUMP

=====

Always replace seals and gaskets. The strainer is fitted to the fuel reservoir by a bayonet connection.

- 1- Silencer 15 Nm
- 2- Seal
 - Renew
- 3- Supply line
- 4- Seal
 - Renew
- 5- Fuel reservoir upper section
- 6- 3 Nm
- 7- Electrical connections
 - M6 positive (+)
 - M5 earth (-)
- 8- Non-return valve
 - Checking, page 20-16
- 9- Fuel pump
 - Checking - page 20-12
- 10- Strainer

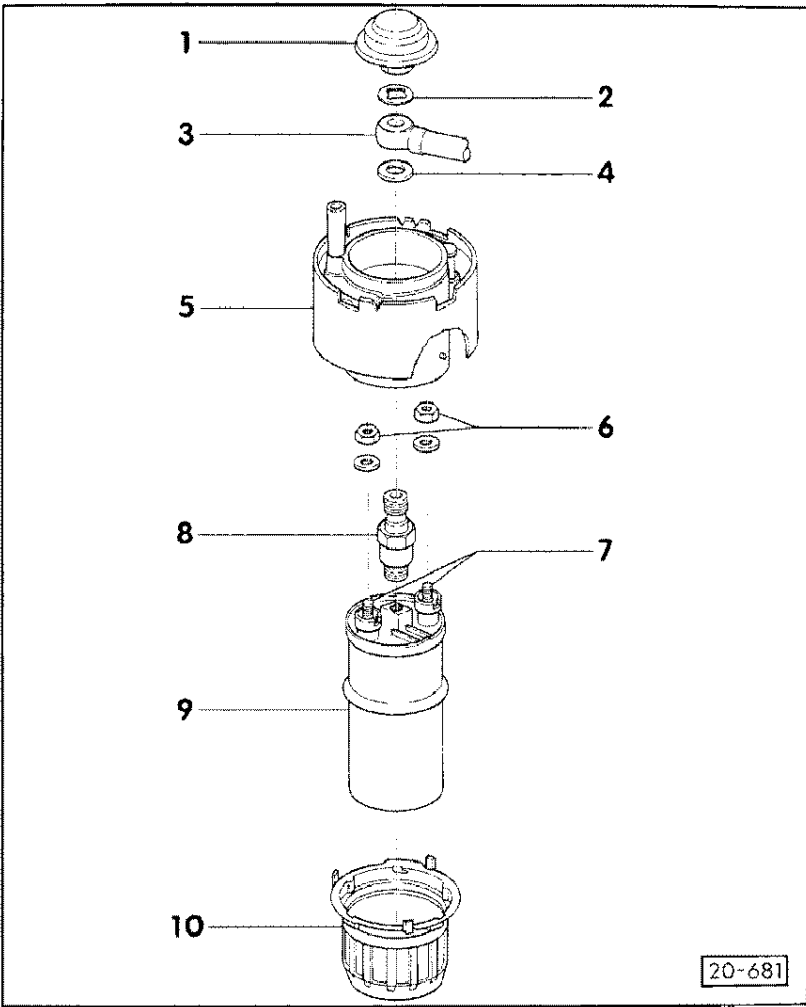

20-681

20-11

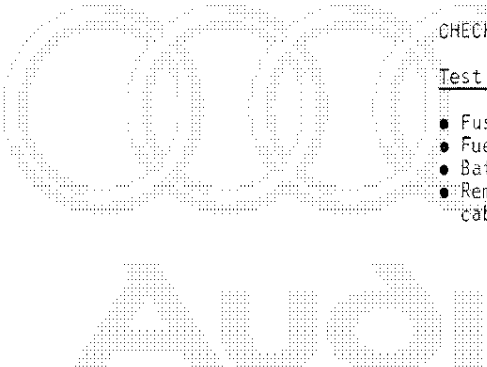

CHECKING FUEL PUMP

Test conditions:

- Fuse OK (No. 13 on relay board with fuse holder)
- Fuel filter OK
- Battery fully charged (12V min)
- Remote control V.A.G 1348/3A connected complete with adapter cable V.A.G 1348/3-2 - page 20-5

Protected by copyright. Copying for private or commercial purposes in part or in whole is not permitted unless authorised by AUDI AG. AUDI AG does not guarantee or accept any liability with respect to the correctness of information in this document. Copyright by AUDI AG

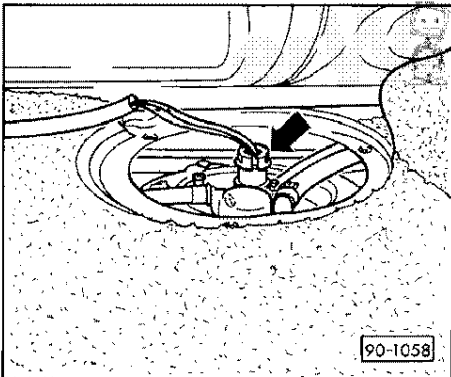

- ▲ - Remove fuel gauge sender and fuel pump cover (below boot floor trim).
- Disconnect fuel pump and fuel gauge connector.

90-1058

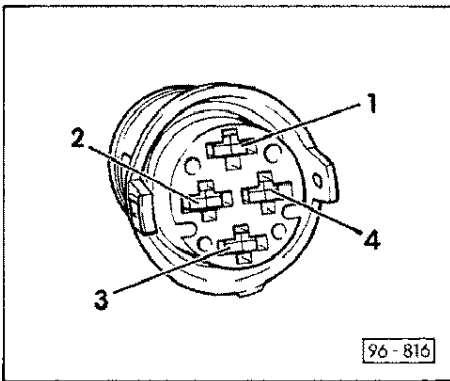

- Check voltage across connector contacts 1 (green/yellow) and 4 (brown) using a voltmeter. Keep remote control switch pressed during the check.

The reading should be approximately equal to the battery voltage.

- If the specified voltage is not available repair open circuit using the current flow diagram.
- If the specified voltage is available re-connect connector.
- Press remote control switch. If the fuel pump is not heard running remove fuel pump - page 20-8.

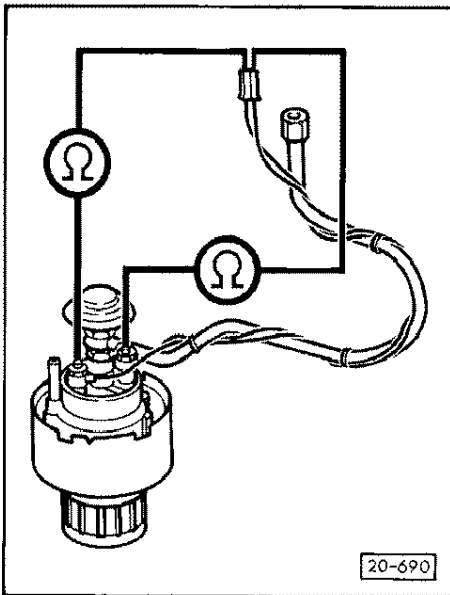

- Check connection between connector and fuel pump for continuity using an ohmmeter.

Specified resistance: 0 ohms.

- If specified reading is not obtained replace connecting cable.
- If specified reading is obtained replace fuel pump.

20-13

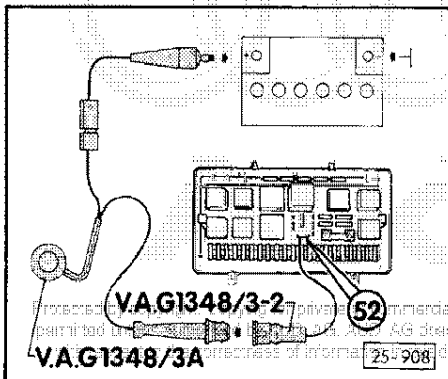

CHECKING FUEL PUMP DELIVERY RATE

Test conditions:

- Fuse OK (No. 13 in relay plate with fuse holder)
- Fuel filter OK
- Battery fully charged (12V min.)

- Connect remote control V.A.G 1348/3A using adapter cable V.A.G 1348/3-2

Withdraw fuel pump relay from relay location 10 on relay plate.

- Connect remote control V.A.G 1348/3A to contact 52 of relay location 10 and to the positive battery terminal using adapter cable V.A.G 1348/3-2.

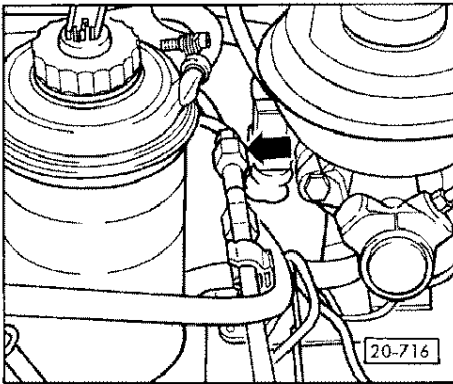

← - Unscrew supply pipe union (upper fuel line) - see arrow.

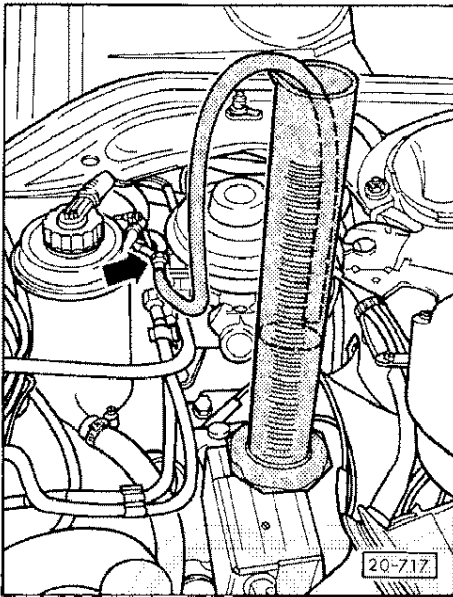

← - Connect a hose to the fuel supply pipe and run other end of hose into a graduated measuring vessel.

20-15

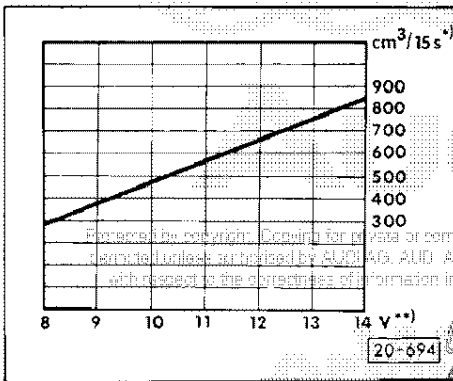

← Check pump delivery rate by pressing the switch of remote control V.A.G 1348/3A for 15 sec.

The specified minimum delivery rate can be read from the diagram.

* Measure minimum delivery rate (cm³/15s) at the fuel return line.

** Check fuel pump voltage with engine switched off and pump running (This voltage should be approx. 2V less than the battery voltage).

20-694

CHECKING FUEL PUMP NON-RETURN VALVE

Note:

For this test fuel pressure regulator, fuel pump and injectors must be working properly and there must be no leaks in the fuel system.

Important

The pressure gauge lever must remain closed during the test.

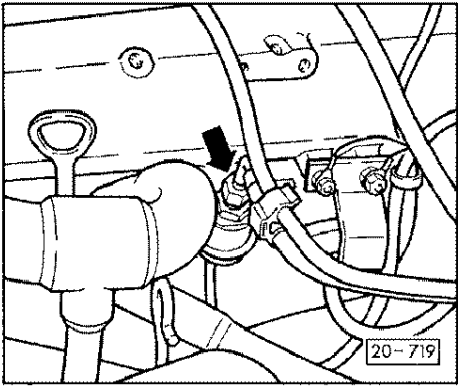

◀ - Disconnect fuel return line from pressure regulator.

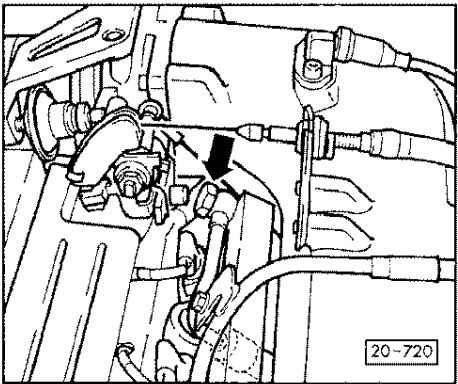

◀ - Disconnect connecting line between fuel ring main and pressure regulator from the fuel ring main.

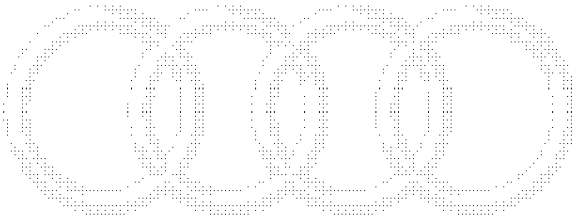

20-17

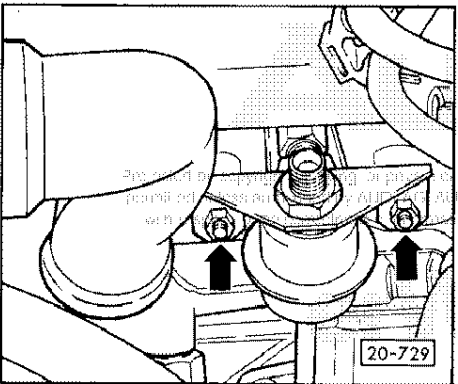

◀ - Unscrew pressure regulator and carefully withdraw from induction manifold complete with connecting line.

This manual is property of Audi AG and is not to be reproduced, in part or in whole, for commercial purposes, in part or in whole, or for any other purpose without the written permission of Audi AG. Audi AG does not assume any liability for errors in this document. Copyright by Audi AG.



◀ - Unscrew connecting line from pressure regulator.

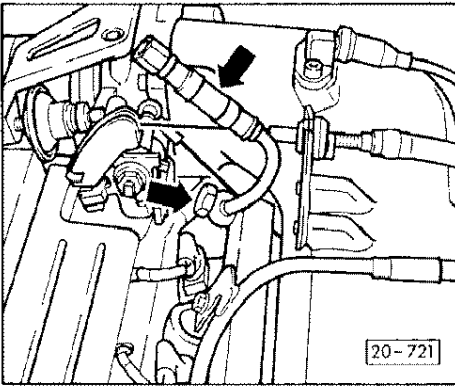

◀ - Connect connecting line to fuel ring main after rotating through 180 degrees.

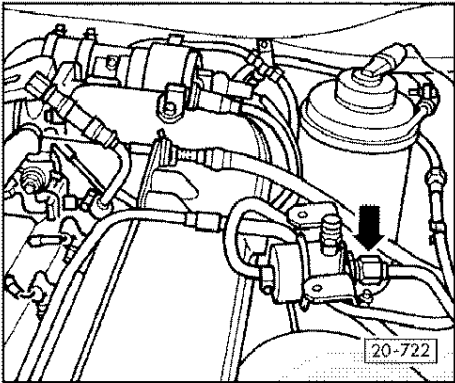

◀ - Connect fuel return line to pressure regulator.

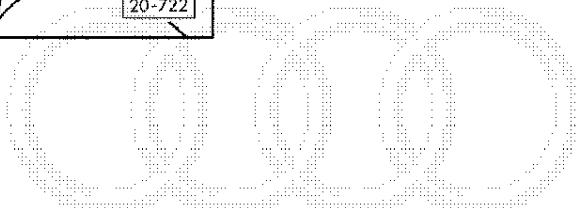

20-19

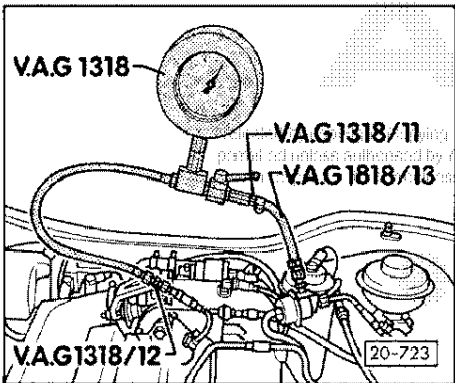

◀ - Connect pressure gauge V.A.G 1318 between connecting line and pressure regulator. Set pressure gauge lever to "open" position.

- Connect remote control V.A.G 1348/3A - page 20-14

- Press remote control switch for approx. 30 sec.

- Set pressure gauge lever to closed position.

- Press remote control switch for a short time until the reading is a maximum of 5.5 bar.

- Observe pressure gauge: maximum pressure drop after 10 min: 0.5 bar.
If pressure drop exceeds this value check pressure gauge and fuel supply line connections for leaks; if there are no leaks replace non-return valve.

20-20

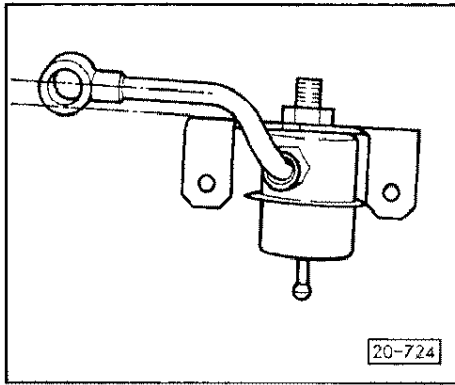

- Installing the pressure regulator is a reversal of removal.

- ◀ Note that the connecting line should be fitted to the pressure regulator in alignment with the pressure regulator bracket.

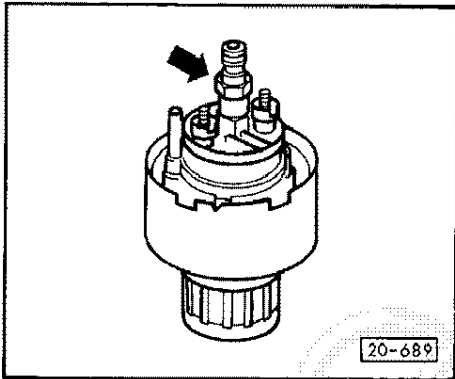

Replacing non-return valve

- Remove fuel pump - page 20-8

- ◀ - Unscrew non-return valve and replace complete with seal.

Tightening torque: 20 Nm

Caution

Do not clamp the electric fuel pump in a vice!

20-21

CHECKING FUEL PUMP RELAY AND RELAY CONTROL CIRCUIT

Checking fuel pump relay (J17)

- Remove fuses 13, 24 and 28.

Protected by copyright. Copying or reuse without the written permission of AUDI AG is prohibited. Copyright by AUDI AG with respect to the correctness of information in this document. Copyright by AUDI AG

- Connect diode test lamp V.A.G 1527 between earth and the right-hand contact of fuse 13.

- Operate starter motor briefly.

- Connect diode test lamp V.A.G 1527 between earth the left-hand contact of fuse 24.

- Operate starter motor briefly.

(If the diode test lamp illuminates as soon as the ignition is switched on connect diode test lamp to the right-hand contact of fuse 24).

- Connect diode test lamp V.A.G 1527 between earth and the left-hand contact of fuse 28.

- Operate starter motor briefly. (If the diode test lamp illuminates as soon as the ignition is switched on connect diode test lamp to the right-hand contact of fuse 28).

- The diode test lamp must illuminate during all three checks and the relay must operate audibly (If relay cannot be heard operating place fingertip on relay housing to check operation).

20-22

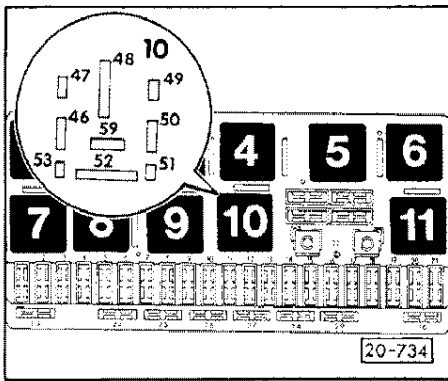

- ◀ - If the diode test lamp does not illuminate the fuel pump relay (J17) should be withdrawn from relay location 10 on the relay plate.
- Check connecting cable between fuse 13 and contact 52 of relay location 10 for continuity using an ohmmeter.
- Check connecting cable between fuse 24 and contact 59 of relay location 10 for continuity using an ohmmeter.
- Check connecting cable between fuse 28 and contact 59 of relay location 10 for continuity using an ohmmeter.
- If necessary repair any open circuit.
- If the relay does not operate check the fuel pump relay control circuit.
- If the control circuit is OK replace fuel pump relay.

Checking fuel pump relay control circuit

- Withdraw fuel pump relay (J17) from relay location 10 on the relay board.
- Switch on ignition.
- Connect voltmeter first to contacts 46 and 50 and then to contacts 48 and 50 of the relay socket.
- The voltmeter should read approx. 12V.



20-23

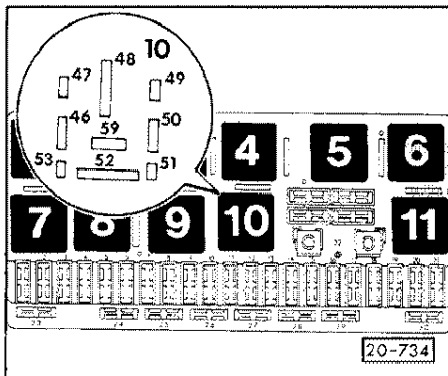

- If the specified readings are not obtained repair open circuit using current flow diagram.
- ◀ - Connect diode test lamp V.A.G 1527 to contacts 46 and 47.
- When the ignition is switched on the diode test lamp should glow dimly and become visibly brighter as soon as the starter motor is operated.
- If the diode test lamp does not become brighter check the wiring as follows:
 Connect test box V.A.G 1598 to the Motronic control unit harness using adapter cable 1598/5 - see repair group 01. (Control unit connector plug disconnected).

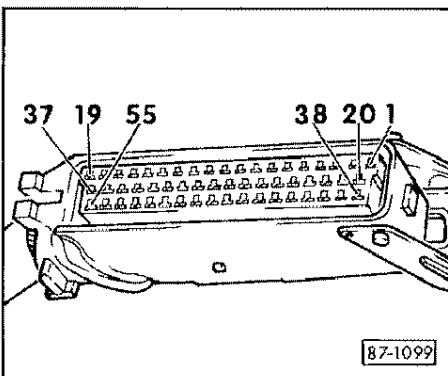

- ◀ - Check connecting cable between contact 47 of relay location 10 and test box socket 3 for continuity and if necessary repair open circuit between contact 47 of relay socket and contact 3 of control unit connector plug.
- If there is no open circuit replace control unit.
- Refit fuses 13, 24 and 28.

REPAIRING ACTIVATED CHARCOAL FILTER TANK VENTING SYST

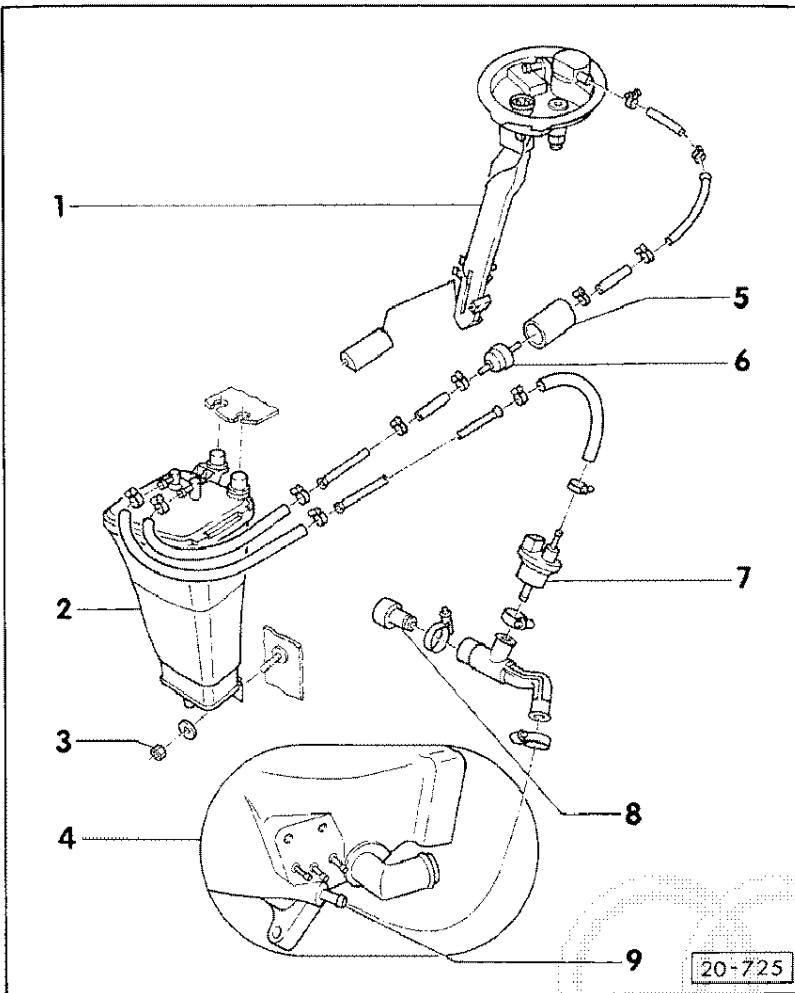

- 1- Fuel gauge sender unit
- 2- Activated charcoal filter
- 3- 10 Nm
- 4- Induction manifold (rear face)
- 5- Support hose
- 6- Breather/vent valve
- 7- Activated charcoal filter solenoid valve
 - Checking - Repair Group 24
 - Checking control circuit, Repair Group 24
- 8- Pressure check valve
(connected to crankcase breather pipe)
- 9- Connection for venting line

20-25

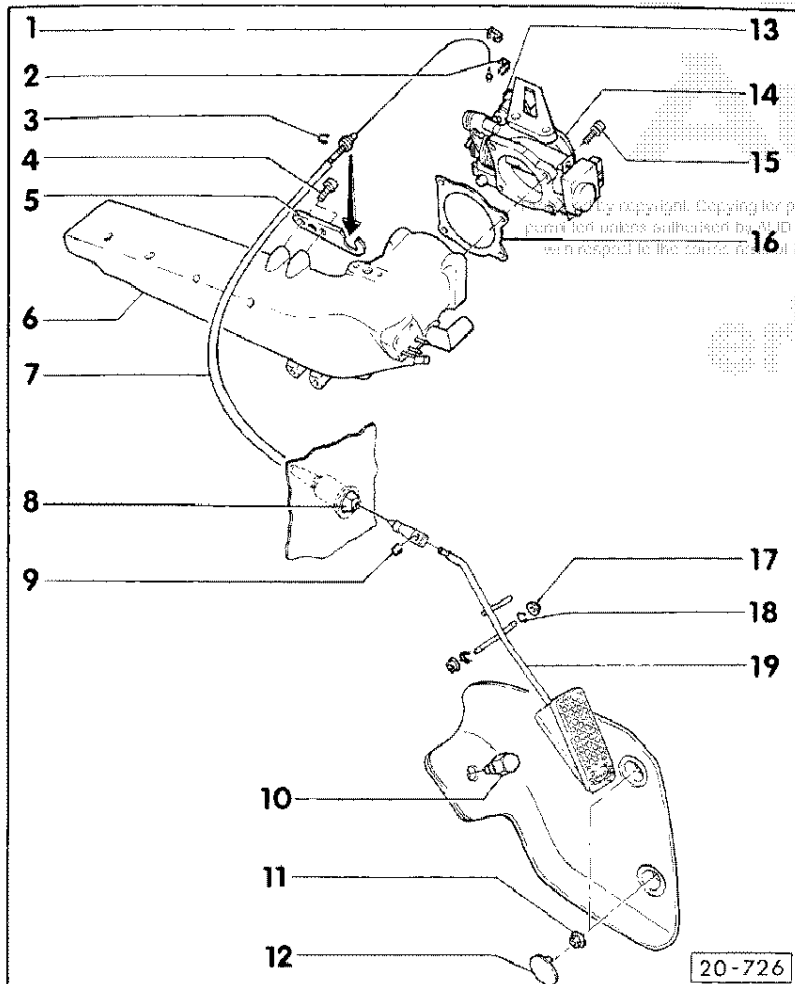

REPAIRING THROTTLE LINKAGE

Please note Caution on page 20-28

- 1- Clamp
- 2- Securing clip
- 3- Securing clip for longitudinal adjustment
- 4- 25 Nm
- 5- Throttle cable abutment
- 6- Induction manifold
- 7- Throttle cable
 - Adjusting - page 20-28
- 8- Square mounting
- 9- Securing clip
- 10- Accelerator pedal stop

20-26

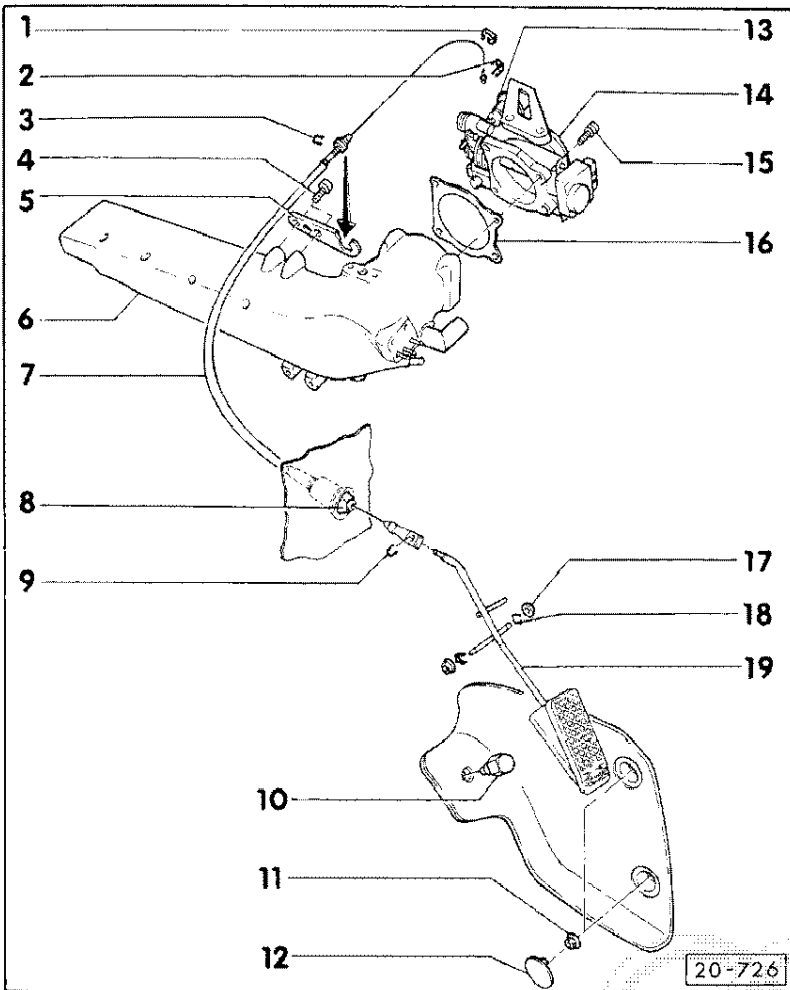

- 11- 10 Nm
- 12- Cap
- 13- Closing damper
 - Adjusting - page 20-31
- 14- Throttle valve housing
- 15- 10 Nm
- 16- Gasket
 - Renew
- 17- Bearing bush
- 18- Securing clip
- 19- Accelerator pedal

ADJUSTING THROTTLE CABLE

Caution

The throttle cable is prone to kinking and should therefore be handled carefully during installation.

A single slight kink can lead to cable fracture during driving. Throttle cables which are kinked must never be installed.

When fitting a throttle cable ensure that the cable is aligned properly between its supports and fixing points.

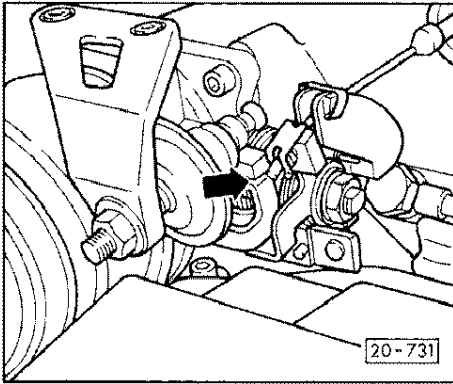

Note:
The throttle cable is fixed to the accelerator pedal and the cam disc. The longitudinal adjustment of the throttle cable sleeve is not fixed by the circlip.

- Fully depress accelerator pedal.
- ◀ - Pull back throttle cable sleeve until the CCS cruise control lever comes to rest against the full load stop.

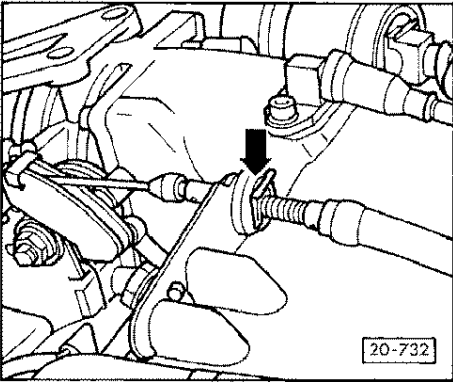

- ◀ - Fix longitudinal adjustment using the clip.

Checking: See next page

20-29

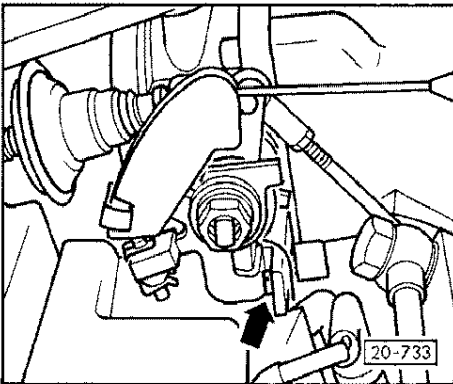

- Checking:
- ◀ - Accelerator pedal in idling position.
 - Push cam disc by hand against idling stop.

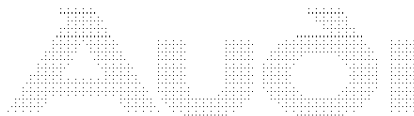

Protected by copyright. Copying for private or commercial purposes, in part or in whole, is not permitted unless authorized by AUDI AG. AUDI AG does not guarantee or accept any liability with respect to the correctness of information in this document. Copyright by AUDI AG.

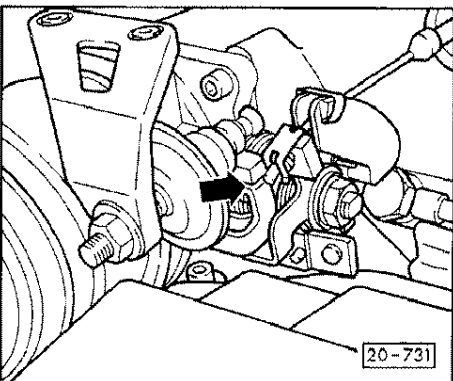

- ◀ - Fully depress accelerator pedal.
 - The cruise control lever must rest against the full load stop.

CHECKING AND ADJUSTING THROTTLE DAMPER

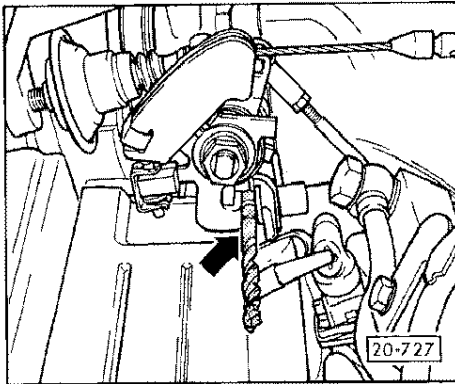

- ← Open throttle valve.
- Clamp a 5.5 mm twist drill centrally between stop and throttle valve lever (see arrow).

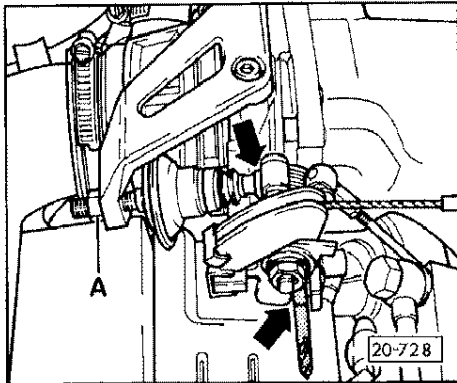

- ← - The throttle damper should just start lifting off the throttle valve roller. If this is not the case slacken locking nut -A- and rotate throttle damper until it no longer touches the roller.
- Re-tighten locking nut -A-.

20-31



Audi

Protected by copyright. Copying for private or commercial purposes, in part or in whole, is not permitted unless authorised by AUDI AG. AUDI AG does not guarantee or accept any liability with respect to the correctness of information in this document. Copyright: by AUDI AG.

erwin 

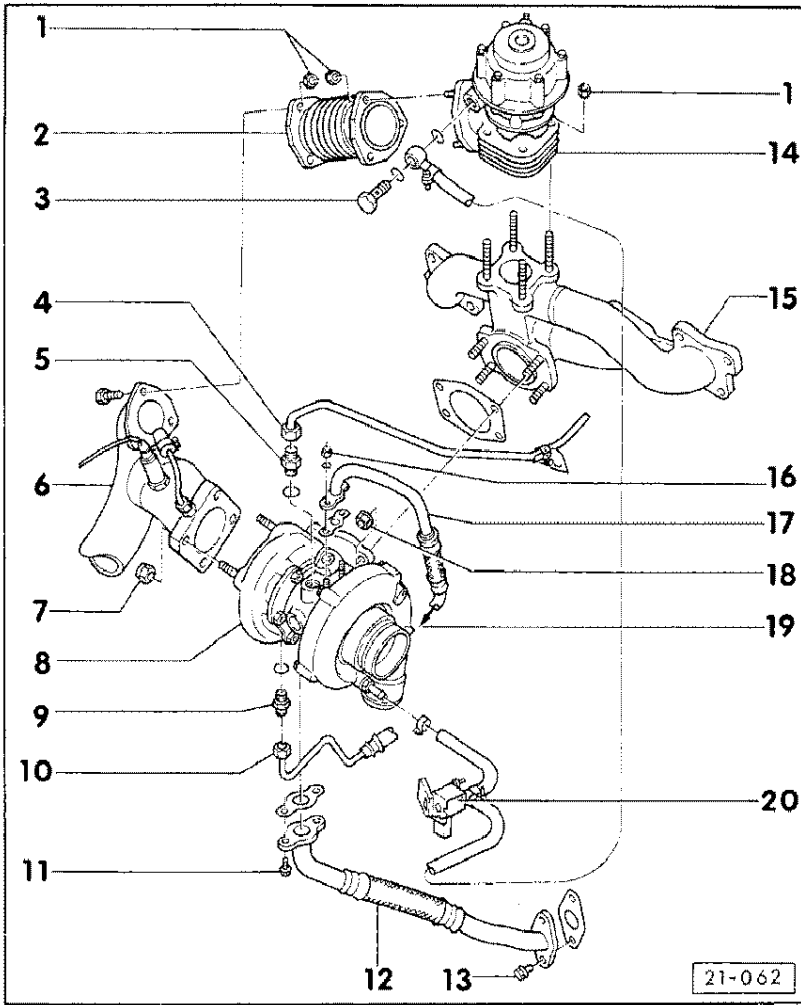

REMOVING AND INSTALLING TURBOCHARGER

COMPONENTS

Note:

Always renew seals and gaskets.

- 1- 25 Nm
- 2- Corrugated pipe
 - The end of the corrugated pipe with a protruding pipe must be towards the by-pass pipe.
- 3- Banjo bolt 25 Nm
- 4- Coolant flow 25 Nm
- 5- Adapter 27 Nm
- 6- Bypass pipe
- 7- 30 Nm
- 8- Turbocharger
 - Checking - page 21-18
 - Removing and installing - page 21-5
- 9- Adapter 35 Nm
- 10- Coolant return line 30 Nm
- 11- 10 Nm
- 12- Oil return line
- 13- 22 Nm

21-1

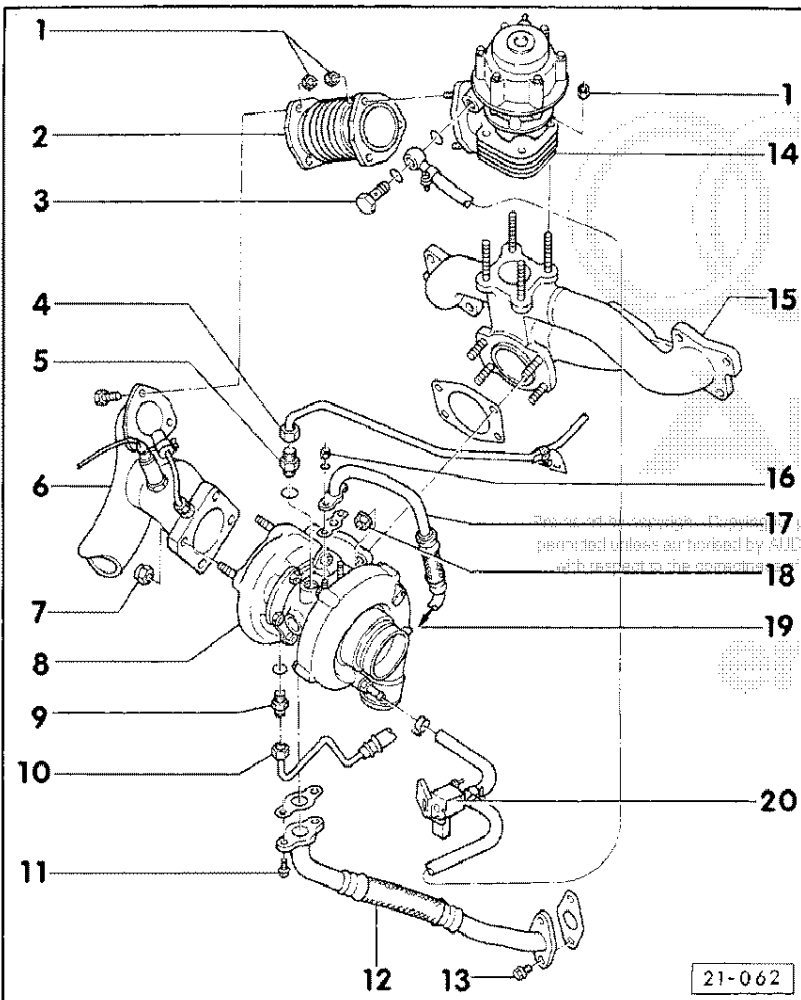

- 14- Wastegate
 - Checking - page 21-18
- 15- Exhaust manifold
- 16- 10 Nm
- 17- Oil flow
- 18- 60 Nm
- 19- To oil filter housing
- 20- Boost pressure limiting solenoid valve
 - Checking - Repair Group 24

21-2

Technical information is provided for informational purposes only. It is not intended to be used as a substitute for the manufacturer's instructions. The manufacturer is not responsible for any damage or injury resulting from the use of this information. Copyright by AUDI AG.



REMOVING AND INSTALLING CHARGE AIR COOLER
 =====
 CRANKCASE VENTILATION COMPONENTS
 =====

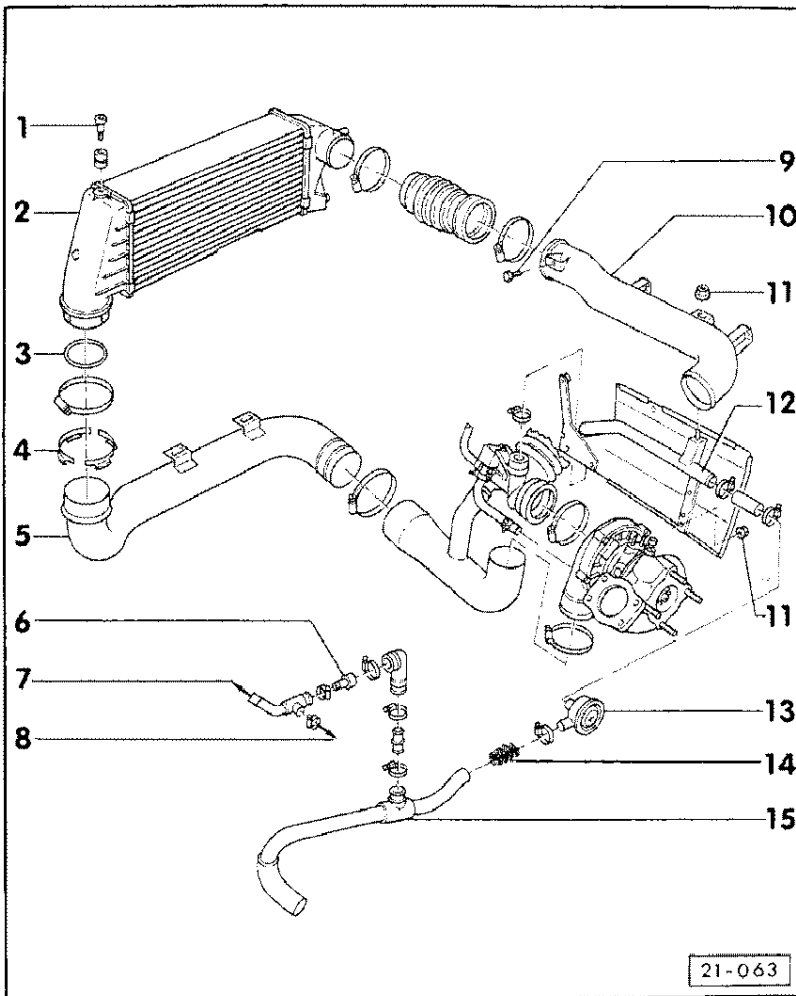

- 1- Collar screw 10 Nm
- 2- Charge air cooler
- 3- O-ring seal
• Renew
- 4- Securing clip (2-piece)
- 5- Boost pipe
- 6- Pressure check valve
- 7- To induction manifold
- 8- To activated charcoal filter solenoid valve
- 9- 22 Nm
- 10- Induction pipe
- 11- 22 Nm

21-063

21-3

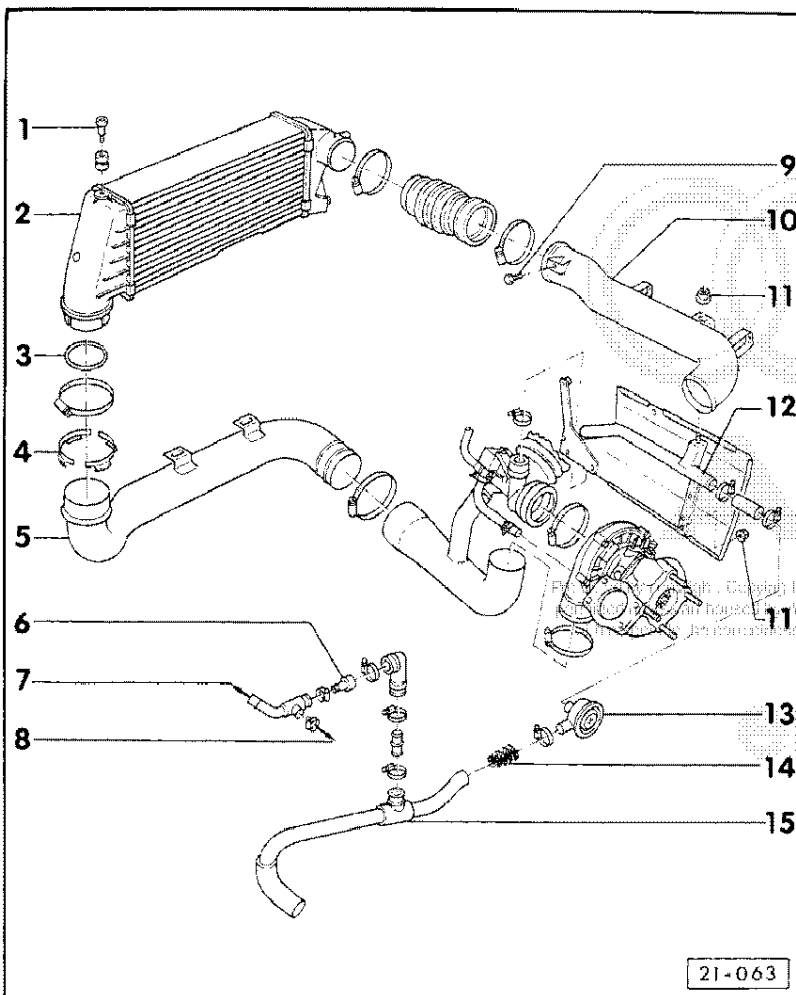

- 12- Crankcase ventilation pipe (rivetted to heat shield)
- 13- Pressure regulating valve
- 14- Flame trap
- 15- Crankcase ventilation hose

21-063

21-4

REMOVING AND INSTALLING TURBOCHARGER

Note:

Always renew seals and self-locking nuts.

- Disconnect battery.

Removing air cleaner

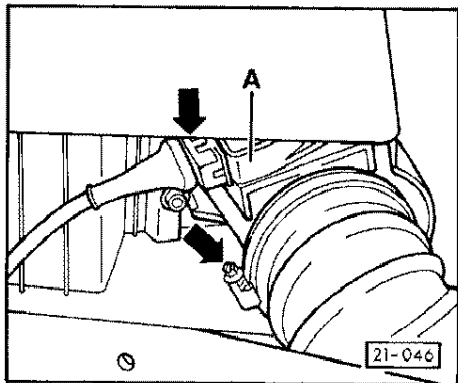

- ◀ - Pull off connector from hot wire air volume meter.
- Release hose clip.
- Pull off hose from hot wire air volume meter.

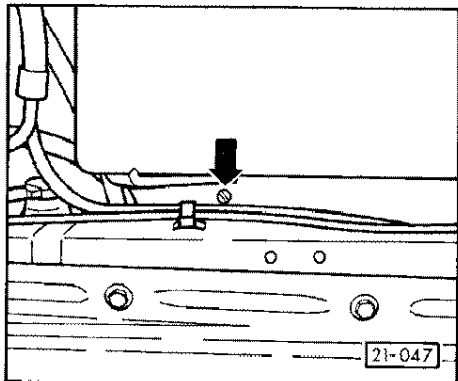

- ◀ - Slacken air cleaner upper section securing screw.

21-5

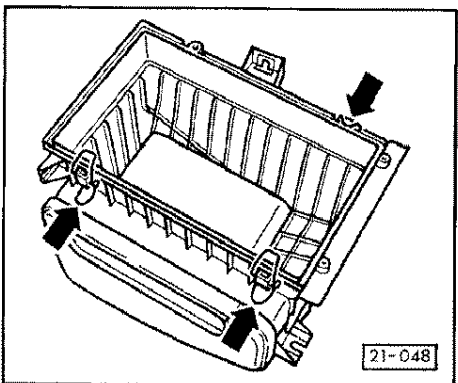

- ◀ - Release spring clips securing air cleaner upper section to lower section.
- Remove air cleaner upper section from engine compartment.

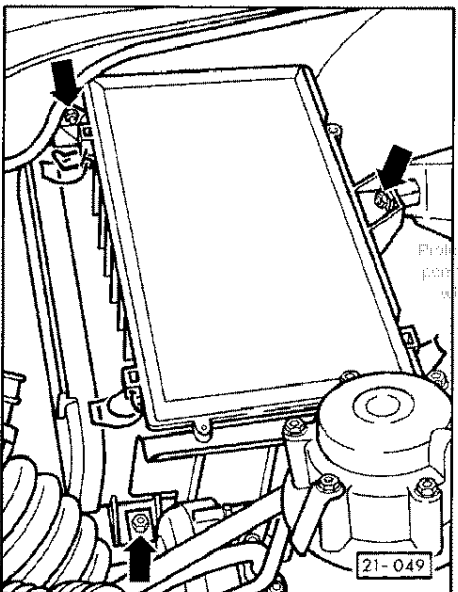

- ◀ - Remove air cleaner lower section.

Protected by copyright. Copying for private or commercial purposes in part or in whole is not permitted unless authorized by AUDI AG. AUDI AG does not guarantee or accept any liability with respect to the correctness of information in this document. Copyright by AUDI AG



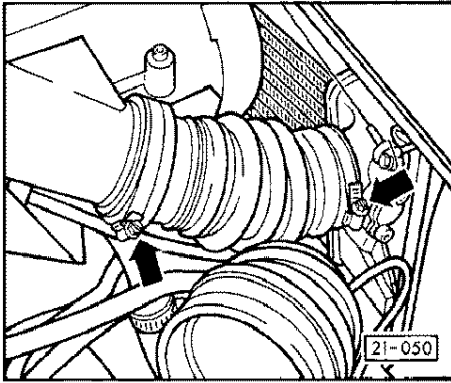

← - Remove connecting hose between charge air cooler and induction pipe.

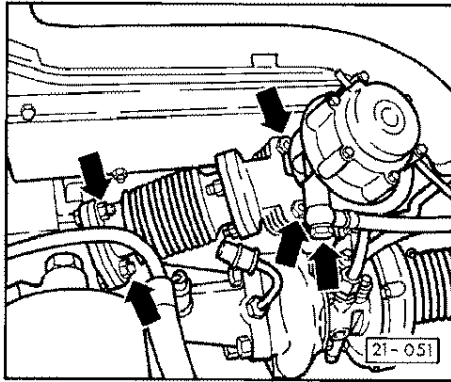

← Removing wastegate

- Disconnect control line from wastegate.

Note:

Keep banjo bolt clean and safe.

- Unbolt corrugated pipe from exhaust pipe.

- Unbolt waste gate from exhaust manifold.

21-7

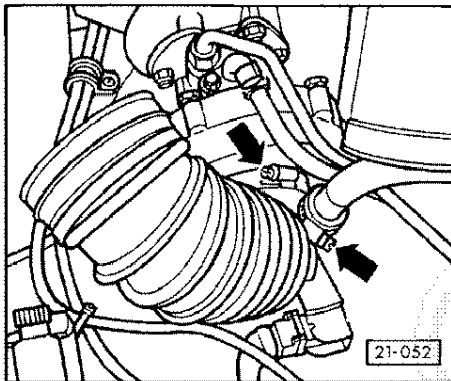

← - Remove hose between hot wire air volume meter and turbocharger from crankcase ventilation pipe and turbocharger by slacking the two hose clips (arrows).

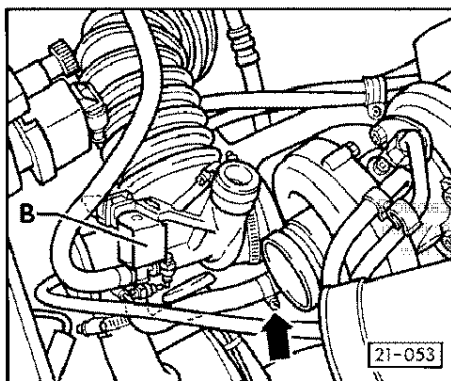

← - Remove connecting hose between turbocharger and boost pressure limiting solenoid valve -B- from turbocharger.

Copyright © Audi AG. Copying for private or commercial purposes, in part or in whole, is not allowed without the written permission of Audi AG. Audi AG does not guarantee or accept any liability for the correctness of information in this document. Copyright © Audi AG.



21-8

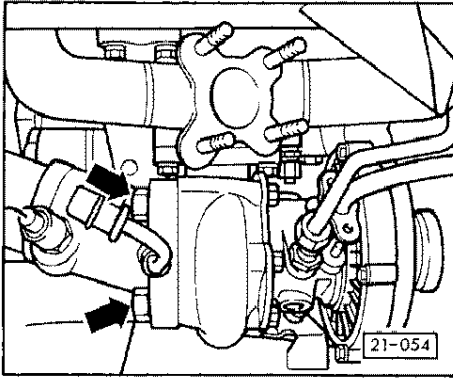

← - Unbolt exhaust pipe from turbocharger.

Note:

The fairly inaccessible nut measures 15 mm across flats.

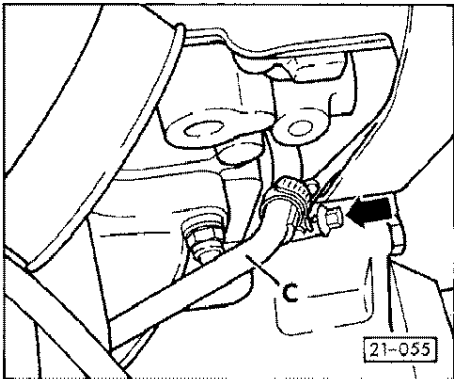

← - Release hose clip securing the coolant flow pipe to the turbocharger -C-.

21-9

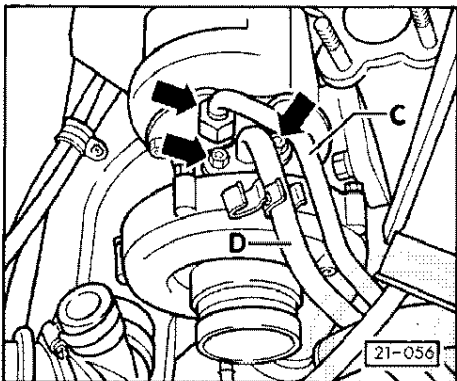

← - Disconnect coolant flow pipe -C- from turbocharger.

- Disconnect oil flow pipe -D- from turbocharger.

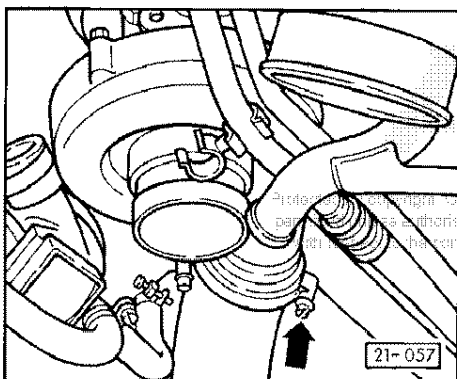

← - Disconnect hose between turbocharger and charge air cooler at turbocharger.

Protected by copyright. Copying for private or commercial purposes, in part or in whole, is not permitted without the express written authorization of AUDI AG. AUDI AG does not guarantee or accept any liability for the completeness of information in this document. Copyright by AUDI AG



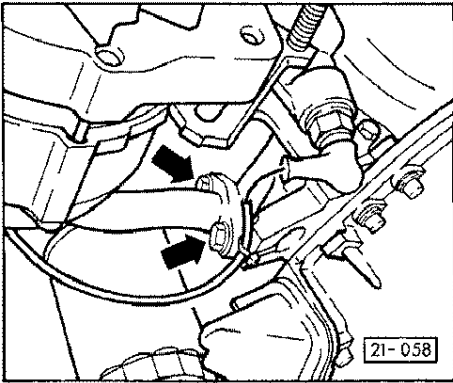

← - Unbolt turbocharger oil return line from crankcase.

Note:

The coolant return line should be plugged immediately after unconnecting.

- Disconnect coolant return line from turbocharger.

21-11

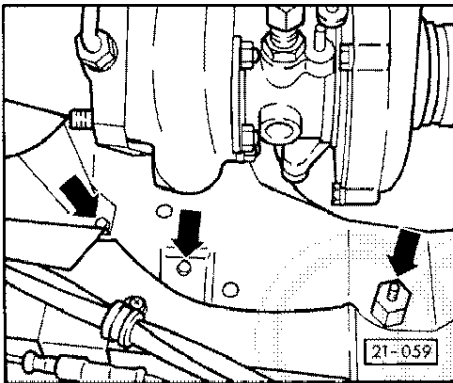

← - Remove heat shield mounted on right-hand side member below turbocharger.

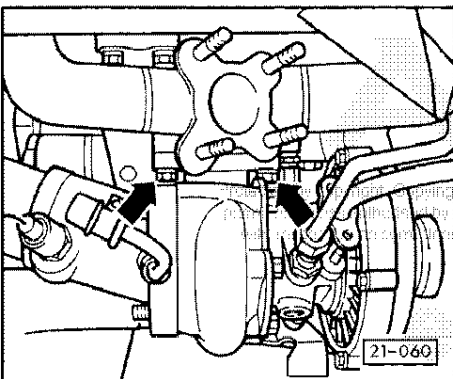

← - Unbolt turbocharger from exhaust manifold and remove.
 - To install the turbocharger reverse removal sequence.

This document is intended for private or commercial purposes, in part or in whole, is not permitted without the written consent of AUDI AG. AUDI AG does not guarantee or accept any liability for the accuracy or completeness of the information in this document. Copyright by AUDI AG.



21-12

REMOVING AND INSTALLING CHARGE AIR COOLER

- Remove and install front bumper - Repair Group 63.
- Remove and install radiator grille - Repair Group 50.

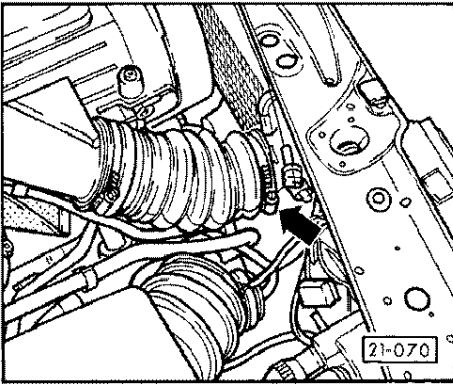

- ◀ - Detach hose between charge air cooler and induction pipe from intercooler.

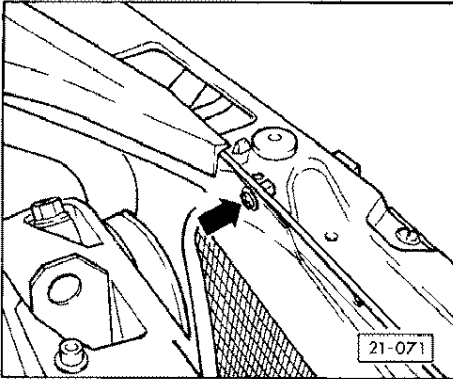

- ◀ - Unscrew side air duct from front panel.

21-13

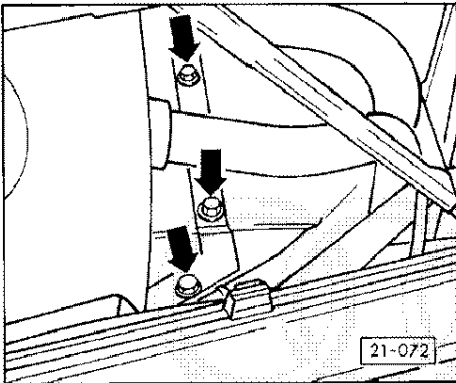

- ◀ - Unscrew side air duct from bottom air duct.

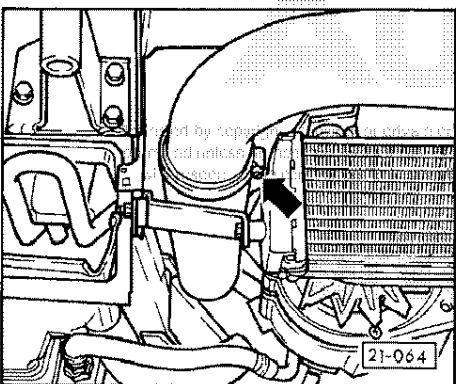

- ◀ - Detach hose between turbocharger and boost pipe from boost pipe.

...ed by dep... in... commercial purposes, in part or in whole, is no... AG does not guarantee or accept any liability... in this document. Copyright by AUDI AG.



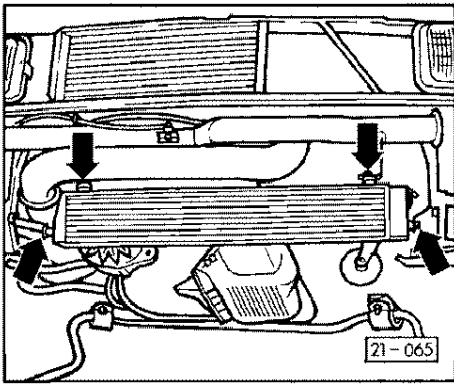

← - Unbolt auxiliary radiator.

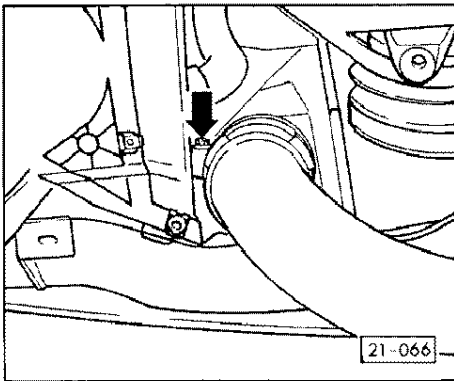

← - Remove boost pipe from charge air cooler by releasing hose clip and 2-piece securing clamp.

21-15

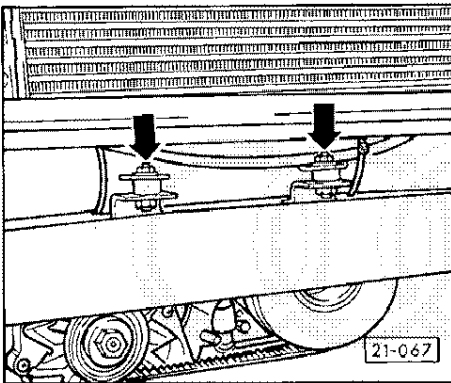

← - Unbolt boost pipe complete with mounting bushes from cross-member and withdraw downward away from charge air cooler.

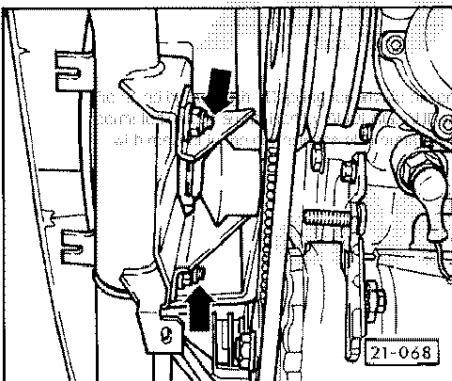

← - Unbolt torque plate from crossmember.

not to be used for any other purpose. In part or in whole, it is not to be used for any other purpose. It does not guarantee or accept any liability for any damage or injury. Copyright by AUDI AG.

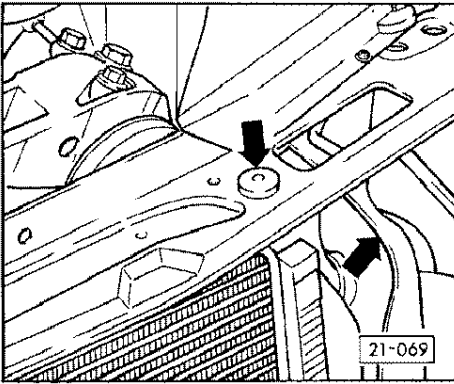

- ◀ - Unbolt charge air cooler from front panel.
- Push side air duct to the left.

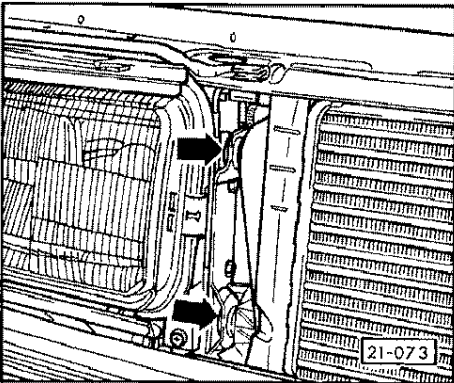

- ◀ - Push charge air cooler to the left out of its rubber mounting.
 - Remove charge air cooler forwards out of engine compartment.
- To install charge air cooler reverse removal sequence.

21-17

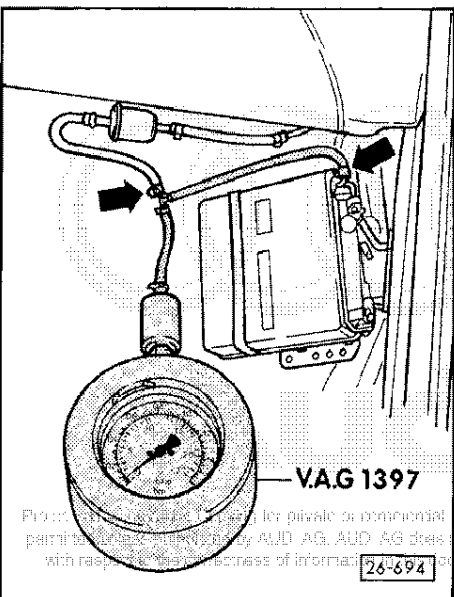

CHECKING TURBOCHARGER AND WASTEGATE

- Engine oil temperature 30 deg. C min.
- No leaking vacuum connections.
- Remove Motronic control unit cover fitted to column -A- in front passenger footwell.
- Remove vacuum hose from Motronic control unit.
- ◀ - Connect turbocharger test instrument V.A.G 1397 between vacuum hose and Motronic control unit.

Note:
 Before checking the boost pressure the vehicle should be taken for a fast run over a distance of at least 3 km (No traffic lights etc.). The boost pressure is measured while the vehicle is being driven. For safety reasons a second person should be present to take the readings from the turbocharger test instrument.

From: ... for private or commercial purposes. All rights reserved. This document is the property of AUD AG. AUD AG does not guarantee the accuracy of the information with respect to the correctness of information. Copyright by AUD AG

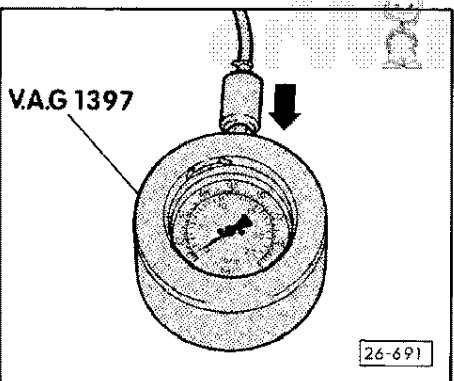

- ◀ - Open turbocharger test instrument valve.
- Fully depress accelerator in fourth gear when the road speed is approx. 60 kph.

21-18

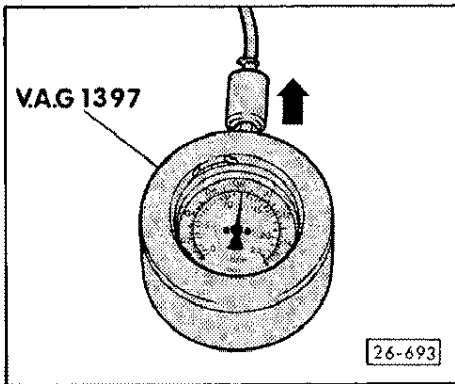

- Observe tachometer.

← Close test instrument valve when engine speed reaches 3000 rpm.

Specified readings:

Bar	Altitude (m)
0.78 - 0.85	Sea level
0.84 - 0.91	600
0.90 - 0.95	1200
0.94 - 0.98	1800
0.97 - 1.03	2400

- If these readings are obtained remove cause of fault in the Motronic fuel injection and ignition system or interrogate fault memory.

- Repair Group 28.

- If the above readings are not obtained check boost pressure limiting solenoid valve control circuit (final control diagnosis).

- Repair Group 28 or replace valve and check.

- If the above readings are not obtained check bypass valve - page 21-21.

21-19

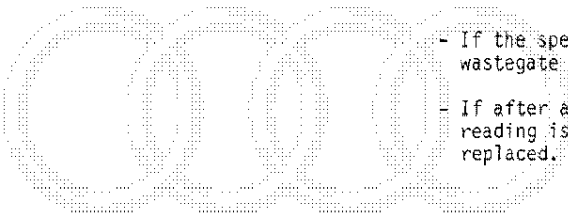

- If the specified reading is not obtained temporarily replace wastegate and check.

- If after a repeated boost pressure check the appropriate reading is still not obtained the turbocharger should be replaced.



Protected by copyright. Copying for private or commercial purposes in part or in whole is not permitted unless authorised by AUDI AG. AUDI AG does not guarantee or accept any liability with respect to the correctness of information in this document. Copyright by AUDI AG

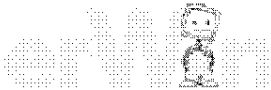

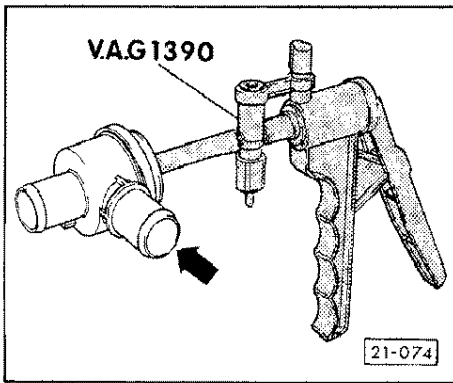

CHECKING OVERRUN BYPASS VALVE USING VACUUM PUMP V.A.G 1390

The overrun bypass valve is fitted in front of the turbocharger. It opens in the overrun phase thus relieving the existing boost pressure from in front of the throttle valve to prevent load shocks when accelerating again.

If the power output is down or shock loads occur during load changes the overrun bypass valve should be checked.

- ◀ - Fit vacuum pump V.A.G 1390 to overrun bypass valve.
- Operate vacuum pump.
 - The bypass valve must open (arrow).
- Operate vacuum pump venting valve after 30 seconds approx.
 - The bypass valve should close (arrow).
- If the overrun bypass valve does not open or close or if the valve is leaking, renew valve.
Secure bypass valve connections using hose clips.

21-21

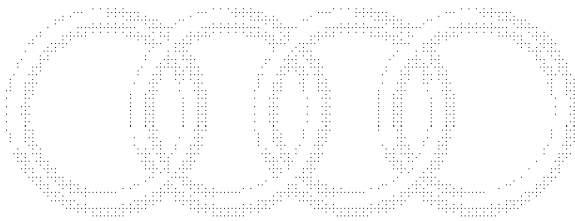

Audi

Protected by copyright. Copying for private or commercial purposes in part or in whole is not permitted unless authorised by AUDI AG. AUDI AG does not guarantee or accept any liability with respect to the correctness of information in this document. Copyright by AUDI AG



REMOVING AND INSTALLING EXHAUST SYSTEM

COMPONENTS

Note:
Always replace gaskets and self-locking nuts.

- 1- 25 Nm
- 2- 25 Nm
- 3- Exhaust manifold gasket
 - Install with beading facing manifold.
- 4- 25 Nm
- 5- 25 Nm
- 6- 25 Nm
- 7- Corrugated pipe
 - The end of the corrugated pipe with a protruding pipe must be towards the by-pass pipe.
- 8- CO take off pipe 20 Nm
- 9- Lambda probe 50 Nm
 - Checking - Repair Group 24
 - Grease thread using G5. G5 must not come into contact with the slot area in the probe body.
- 10- 25 Nm

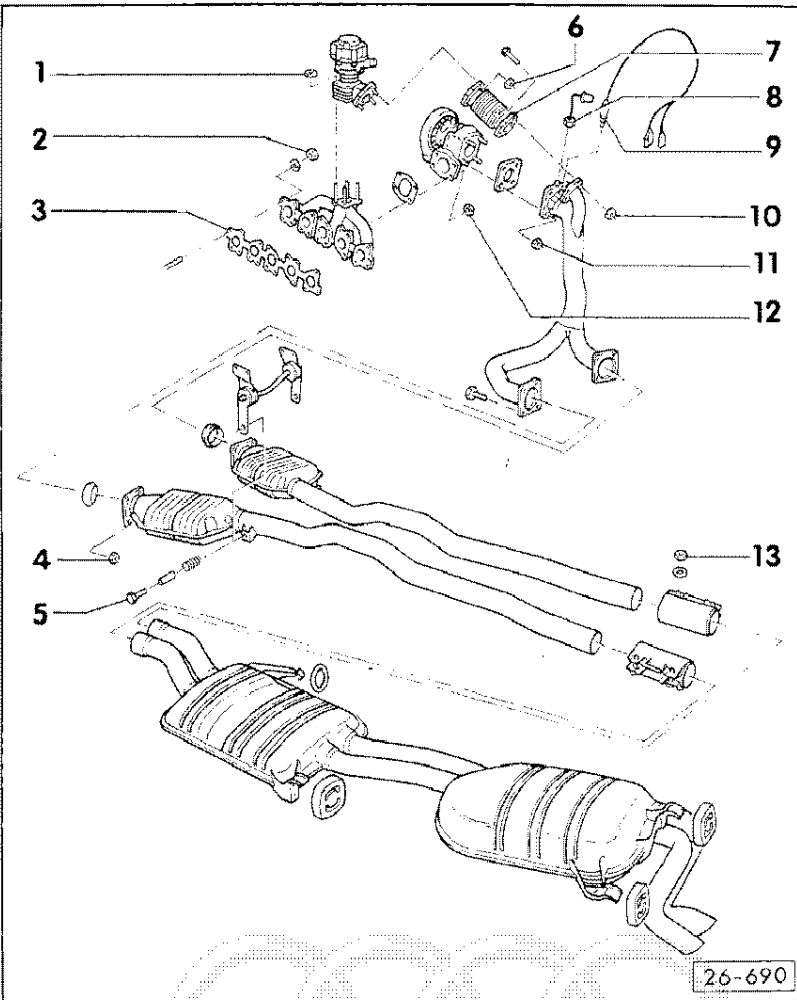

26-1

11- 30 Nm

12- 60 Nm

13- 22 Nm

Separating point between main and rear silencers - Fig. 1 page 26-3

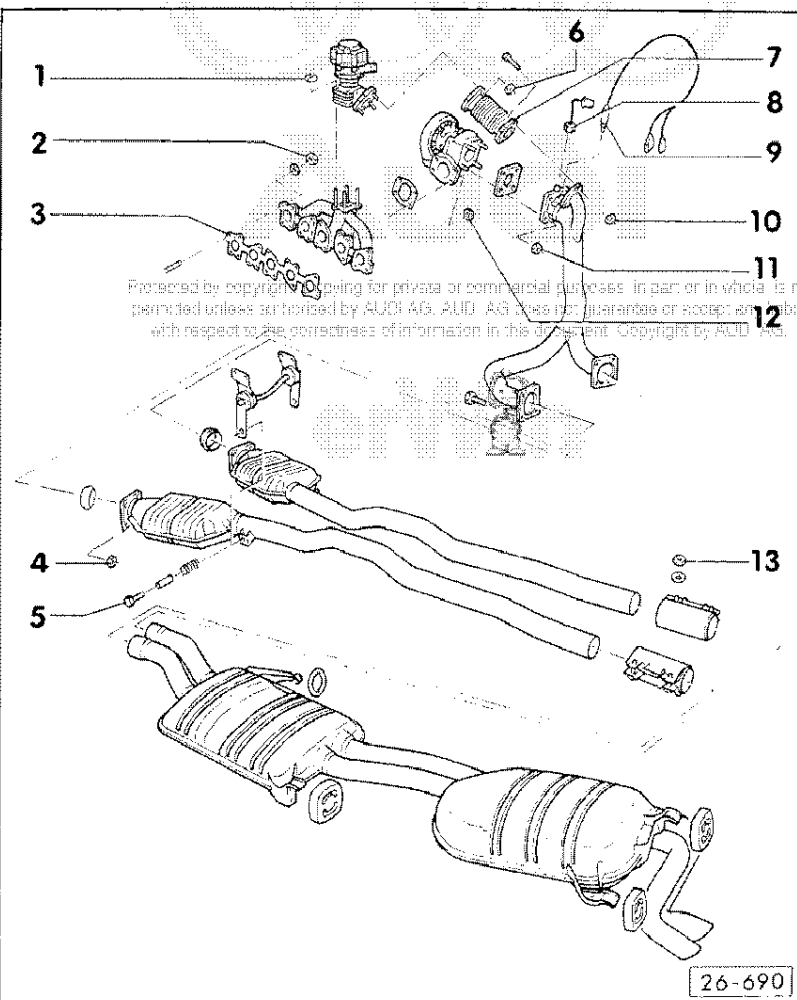

26-2

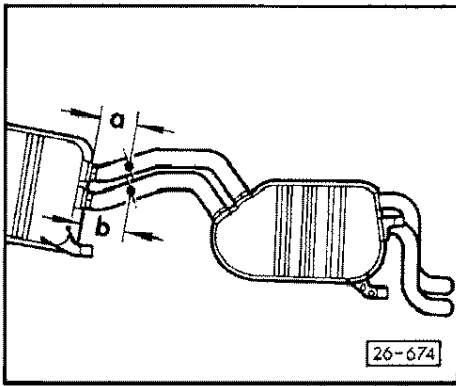

Separating point between main and rear silencers

◄ A separating point is provided to facilitate the replacement of main and rear silencers.

Dimension a = 126.5 mm
Dimension b = 142.5 mm

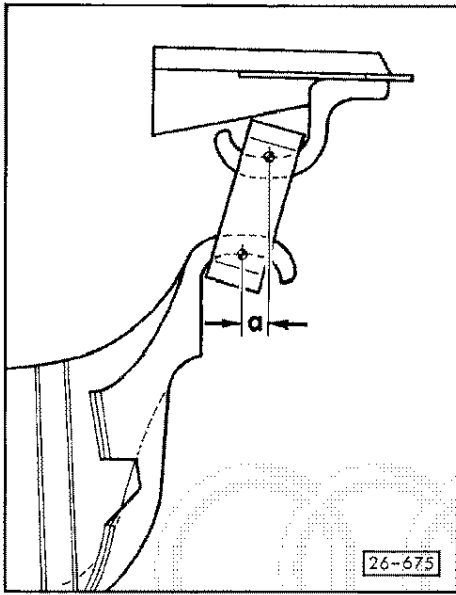

Aligning exhaust system free of stresses

Before tightening the exhaust system bolts ensure sufficient clearance exists between body and exhaust system.

Particular attention should be paid to the following points:

- Clearance between exhaust system and transmission in the crossmember area
- Clearance between exhaust system and rear axle crossmember
- ◄ • Pre-stress (a = 10 mm approx.) at the rear silencer rear mounting.

26-3

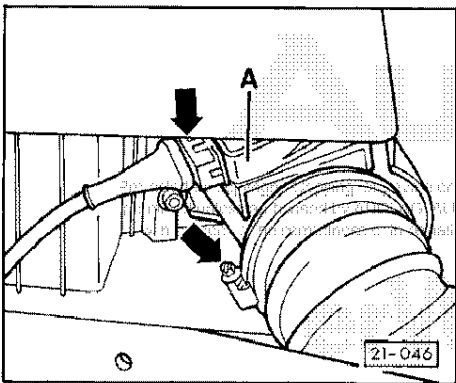

REMOVING AND INSTALLING EXHAUST MANIFOLD

Note:

Always replace gaskets and self-locking nuts.

- Disconnect battery.

Removing air cleaner

◄ - Disconnect connector plug from hot wire air volume sensor -A-.



- Slacken hose clip.

- Pull off hose from hot wire air flow sensor -A-.

◄ - Release air cleaner upper section securing screw.

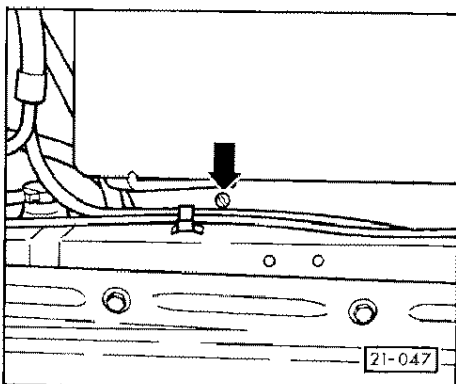

26-4

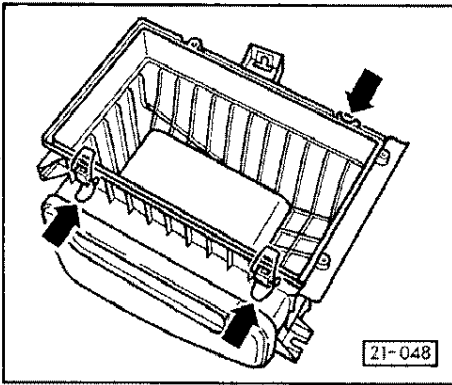

- ◀ - Unclip air cleaner top section from bottom section.
- Remove air cleaner top section from engine compartment.

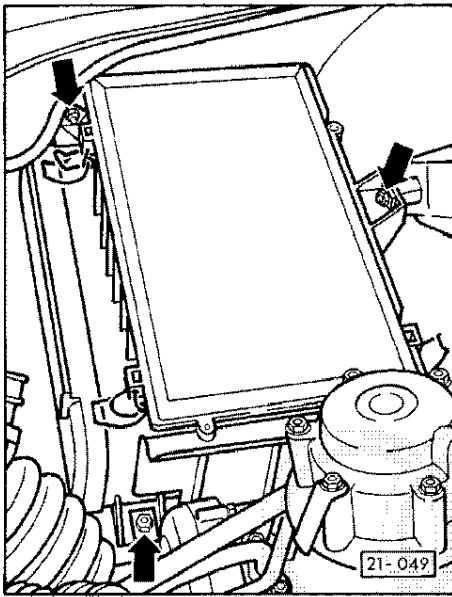

- ◀ - Remove air cleaner bottom section.

26-5

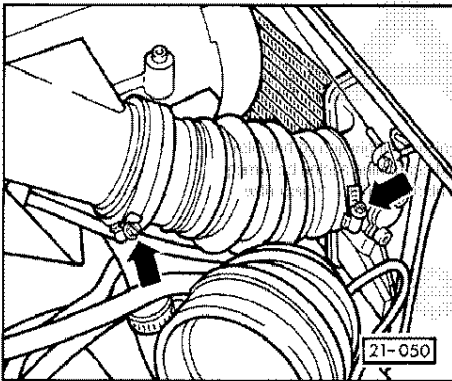

- ◀ - Remove connecting hose between charge air cooler and induction pipe.

For private or commercial purposes, in part or in whole, is not permitted. AUDI AG, AUDI AG does not guarantee or accept any liability for the information in this document. Copyright by AUDI AG



Removing waste gate

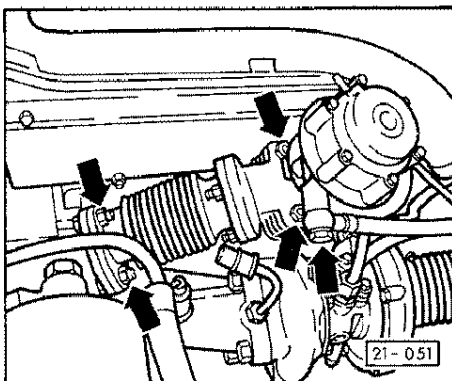

- ◀ - Unscrew control line from waste gate.
- Note:
Keep banjo bolt clean and safe.
- Unbolt corrugated pipe from exhaust pipe.
 - Unbolt waste gate from exhaust manifold.

26-6

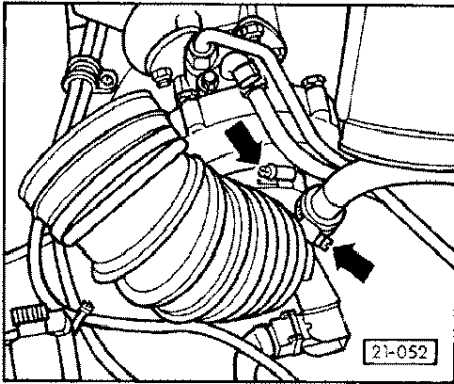

◀ - Remove hose between hot wire air volume sensor and turbocharger from crankcase ventilation pipe and turbocharger by releasing the two hose clips (arrows).

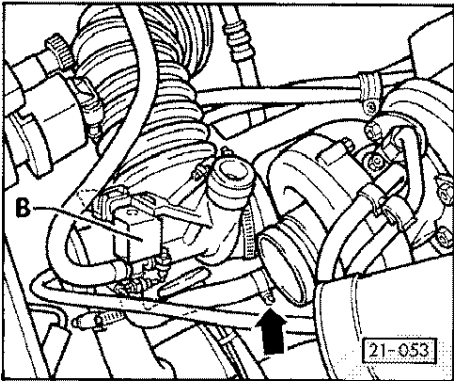

◀ - Remove hose between turbocharger and electrical boost pressure limiting valve -B- from turbocharger.

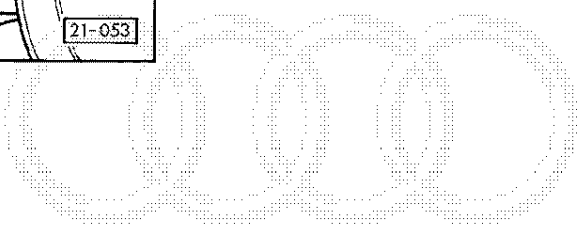

26-7

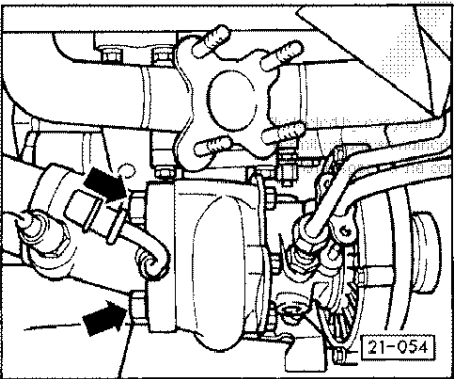

◀ - Unbolt exhaust pipe from turbocharger.

Note:

The fairly inaccessible nut measures 15 mm across flats.

This document is intended for informational purposes only. It is not to be used for copying or reproduction for commercial purposes. In part or in whole, it is not to be used for any other purpose. All rights reserved. Copyright by AUDI AG. AUDI AG does not guarantee as to the complete reliability and correctness of information in this document. Copyright by AUDI AG

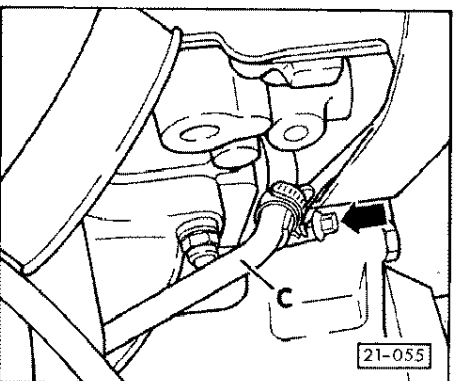

◀ - Release hose clip securing coolant flow pipe -C- to turbocharger.

26-8

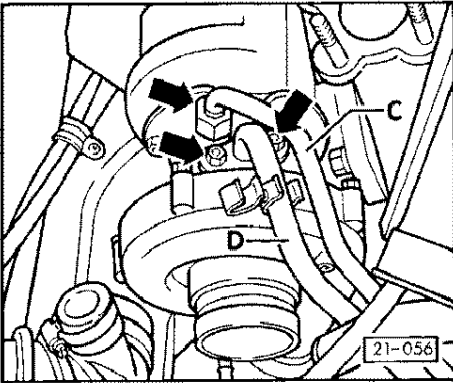

- ◀ - Unscrew coolant flow pipe -C- from turbocharger.
- Disconnect oil flow line -D- from turbocharger.

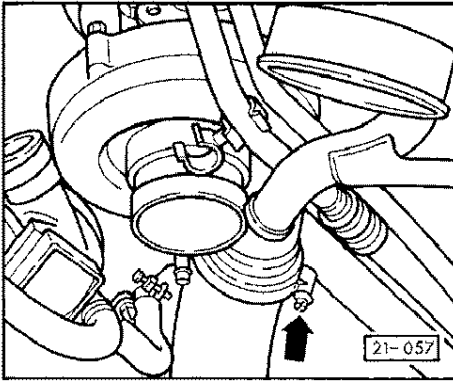

- ◀ - Remove hose between turbocharger and charge air cooler from turbocharger.

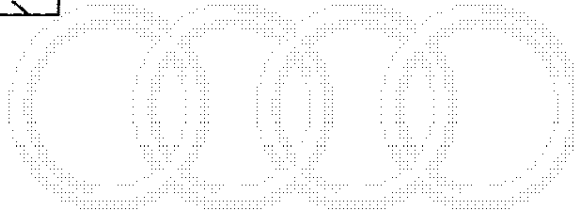

26-9

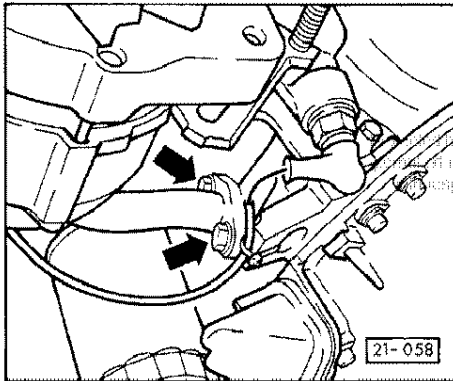

- ◀ - Unbolt turbocharger oil return line from crankcase.

Note:

The coolant return line should be plugged immediately after unbolting.

- Unbolt coolant return line from turbocharger.

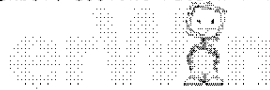

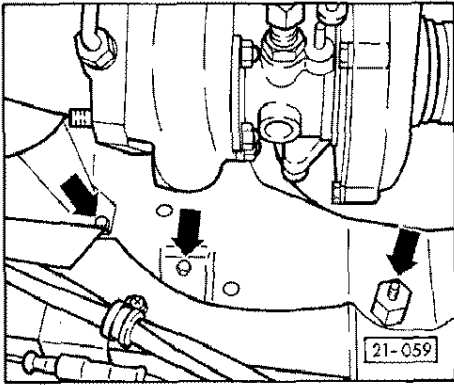

← - Remove heat shield mounted on right-hand side member below turbocharger.

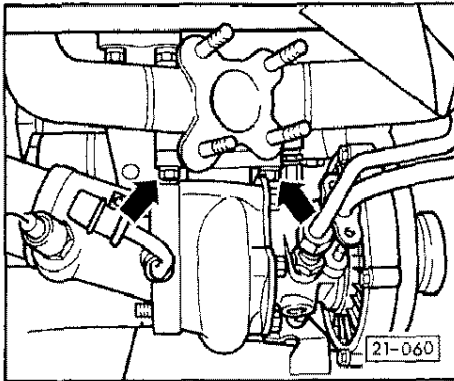

← - Unbolt turbocharger from exhaust manifold and remove.

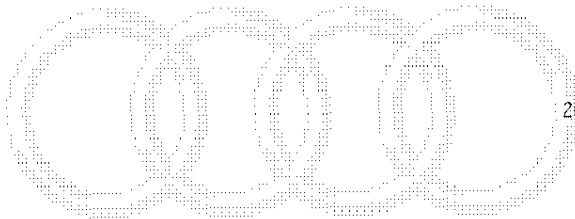

26-11

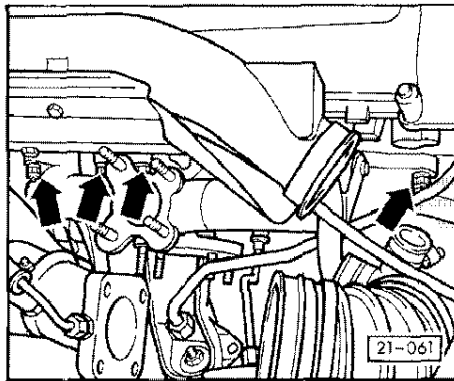

← - Unbolt and remove exhaust manifold.
 - Remove exhaust manifold gasket from cylinder head.

Copyright by Audi AG. Copying for private or commercial purposes in part or in whole is not permitted. To install exhaust manifold reverse removal procedure. In respect to the content of information in this document. Copyright by AUDI AG

Note:

The gasket between exhaust manifold and cylinder head should be fitted in such a way that the gasket beading faces the exhaust manifold.

CHECKING EXHAUST SYSTEM FOR LEAKS

Leaks located in the exhaust system upstream of the Lambda probe can cause

- starting problems
- engine to cut out
- uneven idling
- uneven acceleration
- poor progression

Before fault finding is carried out on the fuel system, Repair Group 24, or ignition system, Repair Group 28.

The exhaust system should be checked for leaks as follows:

- Engine should be cold or hand-warm.
- Engine should be switched off.
- Insert compressed air jet into exhaust system tailpipe and seal with a rag.
- Seal the second tailpipe also with a rag.
- Set compressed air system operating pressure to 6 bar approx.
- Open air jet.
- Check cylinder head joints.



- Check manifold and manifold to downpipe joint.

Spray catalytic converter, joints downstream from catalytic converter etc. with leak detection spray and look for bubbles.

- Repair any leaks found.

Protected by copyright. Copying for private or commercial purposes in part or in whole, is not permitted unless authorized by AUDI AG. AUD AG does not guarantee or accept any liability with respect to the correctness of information in this document. Copyright by AUD AG.



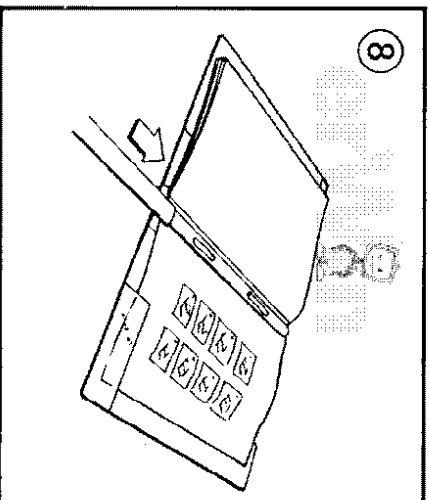
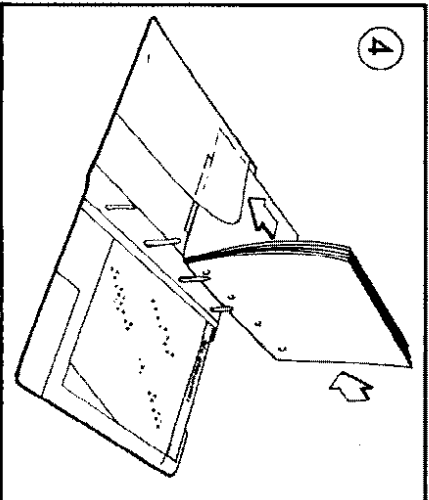
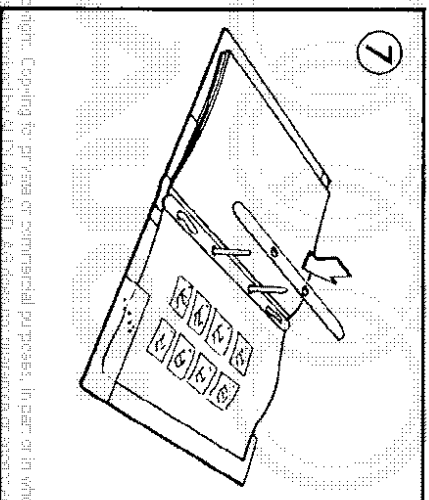
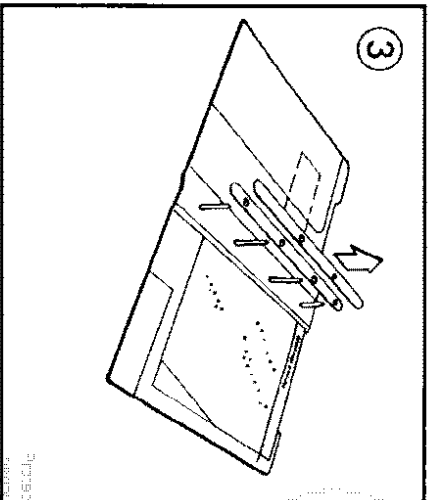
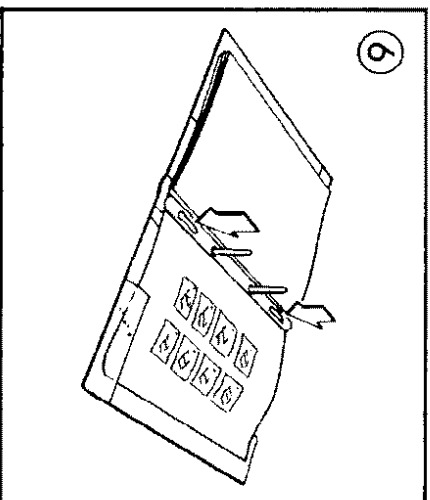
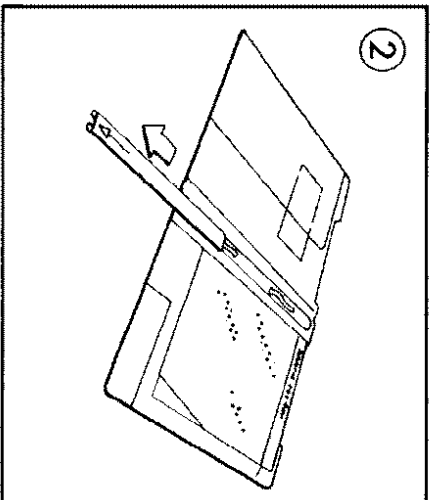
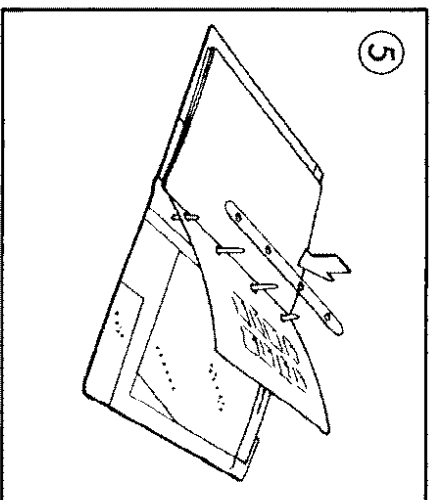
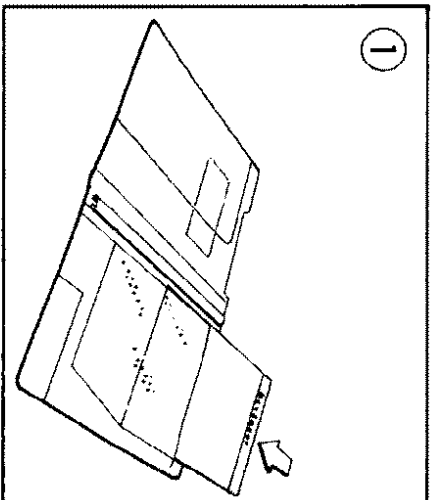

Prepared by: *scrip* Right. Copying for private or commercial purposes, in part or in whole, is not allowed without the express written permission of the publisher. All rights reserved. No part of this publication may be reproduced, stored in a retrieval system, or transmitted, in any form or by any means, electronic, mechanical, photocopying, recording, or by any information storage and retrieval system, without the prior written permission of the publisher. Copyright © 2000 by ALD, A.S.

V.A.G Service.

Workshop Bulletin to Workshop Manual

Audi 100 1983 ►, Audi 200 1984 ►

Engine Code letters	3B																		
Booklet	5-cylinder fuel injection engine, (4-valve), mechanics																		
	Edition 05.89																		

Mark Repair Group Index Column 13

with Bulletin No. **2**

Models affected: all vehicles

Subject	Bulletin page	Booklet from page
Flywheel mounting bolts - Different tightening method	1	13-13

From now on the flywheel mounting bolts must be tightened as follows:

30 Nm and then turn another 1/4 turn (90°)

Notes:

- The additional 1/4 turn can also be done in two stages of 45° if it is not possible to turn the bolts through 90° in one movement.

Protected by copyright. Copying for private or commercial purposes, in part or in whole, is not permitted unless authorised by AUDI AG. AUDI AG does not guarantee or accept any liability with respect to the correct use of information in this document. Copyright by AUDI AG.

- Always install new bolts, and coat with locking compound before installing.

440/444/-

V.A.G Service.

Workshop Bulletin to Workshop Manual

Audi 100 1983 ▶, Audi 200 1984 ▶

Engine Code letters	3B																			
Booklet	5-cyl. F.I. engine (4-valve), mechanics Edition 05.89																			

Mark Repair Group Index Column 21

with Bulletin No. **3**

Models affected: All vehicles

Subject	Bulletin page	Booklet from page
<u>CHECKING TURBOCHARGER AND WASTEGATE</u>	1	21-18

Due to the introduction of turbocharger tester V.A.G 1397/A boost pressure is no longer measured as relative pressure but as absolute pressure. The checking procedure has changed as follows:



Audi

Protected by copyright. Copying for private or commercial purposes, in part or in whole, is not permitted unless authorized by AUDI AG. AUDI AG does not guarantee or accept any liability with respect to the correctness of information in this document. Copyright by AUDI AG.



440/444/-

CHECKING TURBOCHARGER AND WASTEGATE

- Engine oil temperature 30° C min.
- No leaking vacuum connections.
- Remove Motronic control unit cover on -A-pillar in front passenger footwell.
- Remove vacuum hose from Motronic control unit.
- ← Connect turbocharger tester V.A.G 1397/A between disconnected vacuum hose and Motronic control unit.
- Connect plug connector on vacuum hose to connection I on turbocharger tester.
- Set selector switch to position I (absolute pressure range).
- Switch on turbocharger tester.

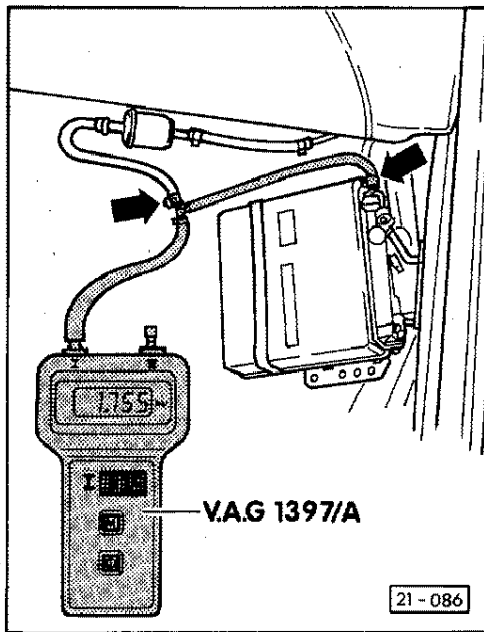

1

Notes:

- When memory button M on turbocharger tester is pressed the last reading is stored until memory button M is pressed again or the tester is switched off.
- A flashing decimal point in the display indicates that a reading has been stored.
- If the battery voltage of the turbocharger tester drops below the permitted limit an arrow appears in the upper left corner of the display.
- Before testing, the vehicle should be taken for a fast run over a distance of at least 3 km (no stops at traffic lights, etc.).
- As the boost pressure is tested during driving for safety reasons a second person should be present to operate the turbocharger tester.

AUDI

Protected by copyright. Copying for private or commercial purposes, in part or in whole, is not permitted unless authorized by AUDI AG. AUDI AG does not guarantee or accept any liability with respect to the correct use of information in this document. Copyright by AUDI AG.



2

- When the road speed is approx. 60 km/h accelerate in fourth gear and observe the rev. counter.

← At 3,000 rpm press memory button M on turbo-charger tester.

- Specified readings:

Altitude (m)	bar
Sea level to 1,200 m	1.825
1,300 m	1.785
1,600 m	1.755
2,300 m	1.755
2,600 m	1.715

- If the specified reading is obtained but there is reduced performance below 2,500 rpm, check for wrong fuel (e.g. less than 95 RON) and check overrun by-pass valve - Repair Group 21.

- If the specified reading is not obtained interrogate fault memory and carry out final control element diagnosis - see Workshop Manual, Motronic fuel injection and ignition system. Temporarily replace wastegate and repeat check.

- If the specified reading is still not obtained replace turbocharger.

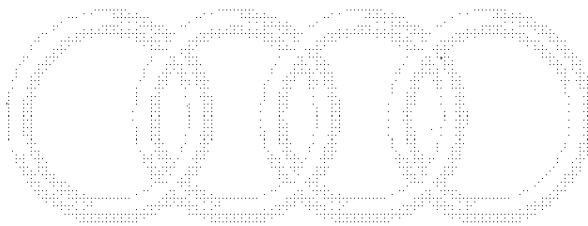
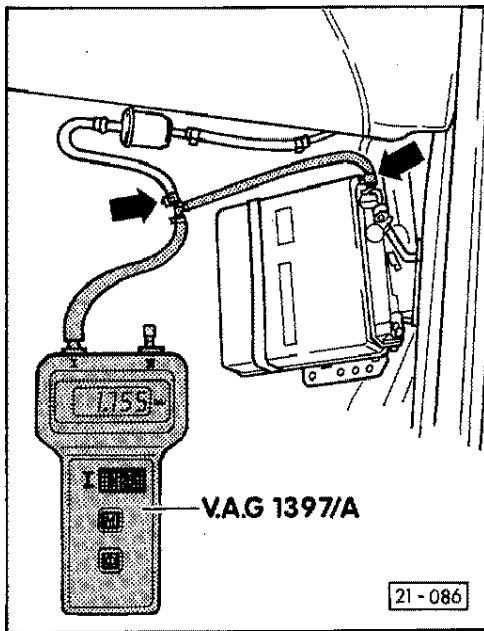

Printed by copyright. Copying for private or commercial purposes in part or in whole is not permitted unless authorized by AUDI AG. AUDI AG does not guarantee or accept any liability with respect to the correctness of information in this document. Copyright by AUDI AG



Technical Bulletin to Workshop Manual

Audi 100 1983 ▶, Audi 200 1984 ▶

Engine code	3 B									
Booklet	5-cylinder fuel injection engine (4-valve), mechanics								Edition 05.89	

Enter in Repair Group list

Repair Group 17

Bulletin No. **4**

Affected: All vehicles

Subject

REMOVING AND INSTALLING OIL SUMP

=====

Contents	Bulletin page	Booklet from page
Removing and installing oil sump	1	17-10



Audi

Protected by copyright: Copying for private or commercial purposes in part or in whole is not permitted unless authorized by AUDI AG. AUDI AG does not guarantee or accept any liability with respect to the correctness of information in this document. Copyright by AUDI AG



440/444/-

AMENDMENT

REMOVING AND INSTALLING OIL SUMP
=====

When installing the oil sump, tighten the M8 screws to 20 Nm first, and then tighten the M6 screws to 10 Nm.



Protected by copyright. Copying or publication for commercial purposes, in part or in whole, is not permitted unless authorised by AUDI AG. AUDI AG does not guarantee or accept any liability with respect to the correctness of information in this document. Copyright by AUDI AG.

